

Premium and Atrium using Unity Pro

Discrete I/O modules
User manual

07/2011

The information provided in this documentation contains general descriptions and/or technical characteristics of the performance of the products contained herein. This documentation is not intended as a substitute for and is not to be used for determining suitability or reliability of these products for specific user applications. It is the duty of any such user or integrator to perform the appropriate and complete risk analysis, evaluation and testing of the products with respect to the relevant specific application or use thereof. Neither Schneider Electric nor any of its affiliates or subsidiaries shall be responsible or liable for misuse of the information contained herein. If you have any suggestions for improvements or amendments or have found errors in this publication, please notify us.

No part of this document may be reproduced in any form or by any means, electronic or mechanical, including photocopying, without express written permission of Schneider Electric.

All pertinent state, regional, and local safety regulations must be observed when installing and using this product. For reasons of safety and to help ensure compliance with documented system data, only the manufacturer should perform repairs to components.

When devices are used for applications with technical safety requirements, the relevant instructions must be followed.

Failure to use Schneider Electric software or approved software with our hardware products may result in injury, harm, or improper operating results.

Failure to observe this information can result in injury or equipment damage.

© 2011 Schneider Electric. All rights reserved.

Table of Contents



	Safety Information	13
	About the Book	15
Part I	Hardware installation of the Discrete I/O modules .	17
Chapter 1	General overview of discrete I/O modules	19
	General description of the Discrete I/O modules.	20
	Physical description of Discrete modules with screw terminal block connection.	21
	Physical description of Discrete modules with HE10 connectors	22
	Catalog of Discrete input modules.	23
	Catalog of Discrete output modules	25
	Catalog of Discrete mixed I/O modules.	29
Chapter 2	General rules for implementing Discrete I/O modules .	31
	Fitting of Discrete I/O Modules	32
	Fitting a screw terminal block to a Discrete I/O module.	34
	Identification of Discrete I/O Modules with Screw Terminal Block Connections	35
	Identification of Discrete I/O Modules with HE10 Connectors.	37
	Choice of direct current power supply for sensors and pre-actuators associated with Discrete I/O modules	39
	Precautions and General Rules for Wiring with Discrete I/O Modules . . .	40
	Means of Connecting Discrete I/O Modules: Connecting Screw Terminal Block Modules	44
	Connecting Discrete I/O Modules: HE10 Connector Modules	46
	Connecting Discrete I/O Modules to TELEFAST Interfaces Using an HE10 Connector	48
	Sensor/Input Compatibility and Pre-Actuator/Output Compatibility.	50
Chapter 3	Fault processing for Discrete I/O modules	55
	General protective measures of Discrete I/O modules	56
	Discrete Inputs/Outputs fault display.	57
	Discrete Inputs/Outputs Fault Diagnostics	60
	Checking the Discrete Input / Output connection	64

Chapter 4	TSX DEY 08D2 input module	67
	Presentation of the TSX DEY 08D2 module	68
	Characteristics of the TSX DEY 08D2 module	69
	Connecting the TSX DEY 08D2 module	71
Chapter 5	TSX DEY 16D2 Discrete input module	73
	Presentation of the TSX DEY 16D2 module	74
	Characteristics of the TSX DEY 16D2 module	75
	Temperature downgrading for the Discrete I/O modules	77
	Connecting the TSX DEY 16D2 module	79
Chapter 6	TSX DEY 16D3 Discrete input module	81
	Presentation of the TSX DEY 16D3 module	82
	Characteristics of the TSX DEY 16D3 module	83
	Connecting the TSX DEY 16D3 module	85
Chapter 7	TSX DEY 16A2 Discrete input module	87
	Presentation of the TSX DEY 16A2 module	88
	Characteristics of the alternating voltage TSX DEY 16A2 module	89
	Characteristics of the 24 VDC negative logic TSX DEY 16A2 module ..	91
	Connecting the alternating voltage TSX DEY 16A2 module	93
	Connecting the 24 VDC negative logic TSX DEY 16A2 module	95
Chapter 8	TSX DEY 16A3 Discrete input module	97
	Presentation of the TSX DEY 16A3 module	98
	Characteristics of the TSX DEY 16A3 module	99
	Connecting the TSX DEY 16A3 module	101
Chapter 9	TSX DEY 16A4 Discrete input module	103
	Presentation of the TSX DEY 16A4 module	104
	Characteristics of the TSX DEY 16A4 module	105
	Connecting the TSX DEY 16A4 module	107
Chapter 10	TSX DEY 16A5 Discrete input module	109
	Presentation of the TSX DEY 16A5 module	110
	Characteristics of the TSX DEY 16A5 module	111
	Connecting the TSX DEY 16A5 module	113
Chapter 11	The TSX DEY 16FK Discrete input module	115
	Presentation of the TSX DEY 16FK module	116
	Specific functions of Discrete modules: programmable input filtering . . .	117
	Specific Functions of Discrete Modules: Input Latching	118
	Specific Functions of Discrete Modules: Input Event Management. . . .	120
	Characteristics of the TSX DEY 16FK module	121
	Connecting the TSX DEY 16FK module	123
Chapter 12	The TSX DEY 32D2K Discrete input module	125
	Presentation of the TSX DEY 32D2K module	126
	Characteristics of the TSX DEY 32D2K module	127
	Connecting the TSX DEY 32D2K module	129

Chapter 13	TSX DEY 32D3K Discrete input module	131
	Presentation of the TSX DEY 32D3K module	132
	Characteristics of the TSX DEY 32D3K module	133
	Connecting the TSX DEY 32D3K module	135
Chapter 14	TSX DEY 64D2K Discrete input module	137
	Presentation of the TSX DEY 64D2K module	138
	Characteristics of the TSX DEY 64D2K module	139
	Connecting the TSX DEY 64D2K module	141
Chapter 15	TSX DSY 08T2 output module	143
	Presentation of the TSX DSY 08T2 module	144
	Characteristics of the TSX DSY 08T2 module	145
	Connecting the TSX DSY 08T2 module	147
Chapter 16	TSX DSY 08T22 Discrete output module	149
	Presentation of the TSX DSY 08T22 module	150
	Characteristics of the TSX DSY 08T22 module	151
	Connecting the TSX DSY 08T22 module	153
Chapter 17	TSX DSY 08T31 Discrete output module	155
	Presentation of the TSX DSY 08T31 module	156
	Characteristics of the TSX DSY 08T31 module	157
	Connecting the TSX DSY 08T31 module	159
Chapter 18	TSX DSY 16T2 Discrete output module	161
	Presentation of the TSX DSY 16T2 module	162
	Characteristics of the TSX DSY 16T2 module	163
	Connecting the TSX DSY 16T2 module	165
Chapter 19	TSX DSY 16T3 Discrete output module	167
	Presentation of the TSX DSY 16T3 module	168
	Characteristics of the TSX DSY 16T3 module	169
	Connecting the TSX DSY 16T3 module	171
Chapter 20	TSX DSY 08R5 Discrete output module	173
	Presentation of the TSX DSY 08R5 module	174
	Relay output contact protection	175
	Characteristics of the TSX DSY 08R5 module	176
	Connecting the TSX DSY 08R5 module	178
Chapter 21	TSX DSY 08R4D Discrete output module	181
	Presentation of the TSX DSY 08R4D module	182
	Fuse protection	184
	Connecting the TSX DSY 08R4D module	184
	Characteristics of the TSX DSY 08R4D module	186
Chapter 22	TSX DSY 08R5A Discrete output module	189
	Presentation of the TSX DSY 08R5A module	190
	Characteristics of the TSX DSY 08R5A module	191
	Connecting the TSX DSY 08R5A module	193

Chapter 23	TSX DSY 16R5 Discrete output module	195
	Presentation of the TSX DSY 16R5 module	196
	Characteristics of the TSX DSY 16R5 module	197
	Connecting the TSX DSY 16R5 module	199
Chapter 24	TSX DSY 08S5 Discrete output module	201
	Presentation of the TSX DSY 08S5 module	202
	Characteristics of the TSX DSY 08S5 module	203
	Connecting the TSX DSY 08S5 module	204
Chapter 25	TSX DSY 16S5 Discrete output module	207
	Presentation of the TSX DSY 16S5 module	208
	Characteristics of the TSX DSY 16S5 module	209
	Connecting the TSX DSY 16S5 module	210
Chapter 26	TSX DSY 16S4 Discrete output module	213
	Presentation of the TSX DSY 16S4 module	214
	Characteristics of the TSX DSY 16S4 module	215
	Connecting the TSX DSY 16S4 module	216
Chapter 27	TSX DSY 32T2K Discrete output module	219
	Presentation of the TSX DSY 32T2K module	220
	Characteristics of the TSX DSY 32T2K module	221
	Connecting the TSX DSY 32T2K module	223
Chapter 28	TSX DSY 64T2K Discrete output module	225
	Presentation of the TSX DSY 64T2K module	226
	Characteristics of the TSX DSY 64T2K module	227
	Connecting the TSX DSY 64T2K module	229
Chapter 29	TSX DMY 28FK Discrete mixed I/O module	231
	Presentation of the TSX DMY 28FK module	232
	Characteristics of the TSX DMY 28FK module	233
	Connecting the TSX DMY 28FK module	236
Chapter 30	TSX DMY 28RFK Discrete mixed I/O module	239
	Presentation of the TSX DMY 28RFK module	240
	Specific functions of the TSX DMY 28RFK module: reflex and timing ..	241
	Characteristics of the TSX DMY 28RFK module	242
	Connecting the TSX DMY 28RFK module	245
Chapter 31	TELEFAST 2 Connection Interface Links for the Discrete I/O Modules	249
31.1	Introduction to the TELEFAST 2 Connection Interfaces for Discrete I/O ..	251
	General Overview of TELEFAST 2 Connection Interfaces for Discrete I/O Modules	252
	TELEFAST 2 Connection Bases Catalog	253
	Combination of Premium I/O modules and TELEFAST 2 connection bases	259

31.2	Connection Principles for the TELEFAST 2 Interfaces for Discrete I/O . .	261
	Connecting a Discrete I/O module to a TELEFAST 2 base interface	262
	Dimensions and Mounting of the TELEFAST 2 Connection Bases	263
31.3	TELEFAST 2 ABE-7H08R10/08R11 and ABE-7H16R10/16R11 Connection Bases	266
	Sensor and Pre-actuator Connections on the ABE-7H08R10/R11 and ABE-7H16R10/R11 Bases	266
31.4	TELEFAST 2 ABE-7H12R10/12R11 Connection Bases	268
	Sensor and Pre-actuator Connections on the ABE-7H12R10/R11 Bases	268
31.5	TELEFAST 2 ABE-7H08R21 and ABE-7H16R20/16R21/16R23 Connection Bases	270
	Sensor and Pre-actuator Connections on the ABE-7H08R21 and ABE- 7H16R20/R21/R23 Bases for Type 2 Inputs	270
31.6	TELEFAST 2 ABE-7H12R20/12R21 Connection Bases	272
	Sensor and Pre-actuator Connections on the ABE-7H12R20/12R21 Bases	272
31.7	TELEFAST 2 ABE-7H08S21/16S21 Connection Bases	274
	Sensor and Pre-actuator Connections on ABE-7H08S21/16S21 Bases with One Isolator per Channel	274
31.8	TELEFAST 2 ABE-7H12S21 Connection Base	276
	Sensor and Pre-actuator Connections on the ABE-7H12S21 Base with 1 Isolator per Channel	276
31.9	TELEFAST 2 ABE-7H16R30/16R31 Connection Bases	278
	Sensor and Pre-actuator Connections on the ABE-7H16R30/R31 Bases	278
31.10	TELEFAST 2 ABE-7H12R50 Connection Base	280
	Sensor and Pre-actuator Connections on the ABE-7H12R50 Bases	280
31.11	TELEFAST 2 ABE-7H16R50 Connection Base	282
	Sensor and Actuator Connections on the ABE-7H16R50 Base	282
31.12	TELEFAST 2 ABE-7H16F43 Connection Base	284
	Actuator Connections on ABE-7H16F43 Output Base with One Fuse and One Isolator per Channel	284
31.13	TELEFAST 2 ABE-7H16S43 Connection Base	285
	Sensor Connections on ABE-7H16S43 Output Base with One Fuse and One Isolator per Channel	285
31.14	TELEFAST 2 ABE-7R08S111/16S111 connection bases	286
	Actuator connections on non removable relay output adaptation bases ABE-7R08S111/16S111	287
	Characteristics of non removable relay output adaptation bases ABE- 7R08S111/16S111	289
31.15	TELEFAST 2 ABE-7R08S210/16S210 connection bases	291
	Actuator connections on non removable relay output adaptation bases ABE-7R08S210/16S210	292
	Characteristics of non removable relay output adaptation bases ABE- 7R08S210/16S210	294

31.16	TELEFAST 2 ABE-7R16S212 connection base	296
	Actuator connections on non removable relay output adaptation bases ABE-7R16S212.	297
	Characteristics of non removable relay output adaptation bases ABE- 7R16S212.	298
31.17	Connection bases TELEFAST 2 ABE- 7S16E2B1/E2E1/E2E0/E2F0/E2M0	300
	Sensor connections on non removable static relay input adaptation bases ABE-7S16E2B1/E2E1/E2E0/E2F0/E2M0	301
	Characteristics of non removable static relay input adaptation bases ABE- 7S16E2B1/E2E1/E2E0/E2F0/E2M0	302
31.18	TELEFAST 2 ABE-7S16S2B0/S2B2 connection bases	303
	Actuator connections on ABE-7S16S2B0/S2B2 static output adaptation bases	304
	Characteristics of static output adaptation bases ABE-7S16S2B0/S2B2	305
31.19	TELEFAST 2 ABE-7S08S2B1 connection base.	306
	Actuator connections on ABE-7S08S2B1 static output adaptation base.	307
	Characteristics of ABE-7S08S2B1 static output adaptation bases	308
31.20	TELEFAST 2 ABE-7S08S2B0 connection base	309
	Actuator connections on the ABE-7S08S2B0 static output adaptation base	310
	Characteristics of the ABE-7S08S2B0 static output adaptation bases	311
31.21	TELEFAST 2 ABE-7R16T210/P16T210 connection bases.	312
	Actuator connections on ABE-7R16T210/P16T210 electromechanical or static output relay bases (size 10 mm)	312
31.22	TELEFAST 2 ABE-7R16T212/P16T212 connection bases.	314
	Actuator links on ABE-7R16T212/P16T212 electromechanical or static output relay bases (size 10 mm)	314
31.23	TELEFAST 2 ABE-7R16T230 connection base	316
	Actuator connections on ABE-7R16T230 electromechanical output relay bases (size 10 mm)	316
31.24	TELEFAST 2 ABE-7R16T231 connection base	317
	Actuator connections on ABE-7R16T231 electromechanical output relay base (size 10 mm)	317
31.25	TELEFAST 2 ABE-7P16T214 connection base.	319
	Actuator connections on ABE-7P16T214 electromechanical or static output relay bases (size 10 mm)	319
31.26	TELEFAST 2 ABE-7P16T215 connection base.	321
	Actuator connections on ABE-7P16T215 electromechanical or static output relay bases (size 10 mm)	321
31.27	TELEFAST 2 ABE-7R16T330/P16T330 connection bases.	323
	Actuator connections on ABE-7R16T330/P16T330 electromechanical output relay bases (size 12.5 mm).	323

31.28	TELEFAST 2 ABE-7R16T332/P16T332 connection bases	325
	Actuator connections on ABE-7R16T332/P16T332 electromechanical output relay bases (size 12.5 mm)	325
31.29	TELEFAST 2 ABE-7R16T370 connection base	327
	Actuator connections on ABE-7R16T370 electromechanical output relay bases (size 12.5 mm)	327
31.30	TELEFAST 2 ABE-7P16T334 connection base	329
	Actuator connections on ABE-7P16T334 electromechanical or static output relay bases (size 12.5 mm)	329
31.31	TELEFAST 2 ABE-7P16T318 connection base	331
	Actuator connections on ABE-7P16T318 electromechanical or static output relay base (width 12.5 mm)	331
31.32	TELEFAST 2 ABE-7P16F310 connection base	333
	Sensor connections on ABE-7P16F310 static input relay base (width 12.5 mm)	333
31.33	TELEFAST 2 ABE-7P16F312 connection base	334
	Sensor connections on ABE-7P16F312 static input relay bases (size 12.5 mm)	334
31.34	TELEFAST 2 Connection Base Accessories	335
	TELEFAST 2 Connection Base Accessories Catalog.	336
	Association Table for the Relays on ABE-7R16Txxx, ABE-7P16Txxx and ABE-7P16Fxxx Bases	338
	Characteristics of the Removable ABR-7xxx Electromechanical Output Relays	340
	Characteristics of the Removable ABS-7Exx Static input Relays	341
	Characteristics of the Removable ABS-7Sxx Static Output Relays	342
Chapter 32	Implementation of safety modules	343
32.1	General presentation of the safety modules	344
	General description of safety modules	345
	Physical description of the safety modules	346
	Catalog of safety modules.	347
32.2	Safety functions.	348
	Product user functions.	349
	Operating modes.	350
	Functional diagrams	353
32.3	General rules for the installation of safety modules	355
	Mounting Safety Modules	356
	Identification of safety modules	358
32.4	Precautions and general rules for wiring.	360
	Wiring precautions.	361
	Cable dimensions and lengths	363
32.5	Connection and wiring examples	365
	The safety system	366
	TELEFAST pin assignment for safety modules.	367
	The TSX CPP 301 cable.	370

	Connection of emergency stop buttons and safety switches	372
	Feedback loop connection	375
	Reactivation connection	376
	Safety outputs	377
	Modules in series	378
32.6	Maintenance and diagnostics	379
	Fault detection	380
	Displaying safety module faults	382
	Diagnostics of safety modules	383
	Maintenance table	385
	Test procedure	387
32.7	TSX PAY 262 module	389
	Presentation of the TSX PAY 262 module	390
	Characteristics of the TSX PAY 262 module	391
32.8	TSX PAY 282 module	394
	Presentation of the TSX PAY 282 module	395
	Characteristics of the TSX PAY 282 module	396
Part II Discrete Input/Output Modules Software		
	Implementation	399
Chapter 33	General Information about the Discrete Application-Specific Function	401
	Installation Phase Overview	401
Chapter 34	Configuration of the Discrete Specific-Application	403
34.1	Configuration of a Discrete module: General information	404
	Description of the Discrete Module Configuration Screen	404
34.2	Discrete Input and Output Track Parameters	407
	Discrete Input Parameters on the Rack	408
	Discrete Output Parameters for 8 Channel Modules in Rack	410
	Over 8 track modules on rack Discrete Output Parameter for Modules with more than 8 Channels on the Rack	411
34.3	Configuration of discrete parameters	412
	How to Modify the Task parameter of a Discrete module	413
	How to Modify the External Power Supply Error Monitoring Parameter of a Discrete Module	414
	How to Modify the Function Parameter of a Discrete Input Module	415
	How to Modify the Filtering Parameter of a Discrete Input Module	417
	How to modify the Fallback Mode Parameter of a Discrete Output Module	418
	How to modify the Output Reactivation Parameter of a Discrete Module	419

Chapter 35	Description of the Discrete Specific-Application Language Objects	421
35.1	Language Objects and IODDT	422
	Description of the Discrete Function Objects Languages	423
	Implicit Exchange Language Objects Associated with the Application-Specific Function	424
	Explicit Exchange Language Objects Associated with the Application-Specific Function	425
	Management of Exchanges and Reports with Explicit Objects	427
35.2	IODDTs of the Discrete modules	431
	Details about T_DIS_IN_GEN Type IODDT Implicit Object Exchange	432
	Details about T_DIS_IN_STD Type IODDT Implicit Object Exchange	433
	Details about T_DIS_IN_STD Type IODDT Explicit Object Exchange	434
	Details about T_DIS_EVT Type IODDT Implicit Object Exchange	436
	Details about T_DIS_EVT Type IODDT Explicit Object Exchange	437
	Details about T_DIS_OUT_GEN Type IODDT Implicit Object Exchange	439
	Details about T_DIS_OUT_STD Type IODDT Implicit Object Exchange	440
	Details about T_DIS_OUT_STD Type IODDT Explicit Object Exchange	441
	Details about T_DIS_OUT_REFLEX Type IODDT Implicit Object Exchange	443
	Details for T_DIS_OUT_REFLEX Type IODDT Explicit Object Exchange	444
	Details of the Language Objects of the T_GEN_MOD-Type IODDT	446
	Security Modules Language Objects Details	447
Chapter 36	Debugging of discrete modules	449
	Introduction to the Debugging function of a discrete module	450
	Description of the debug screen of a discrete module	451
	How to access the forcing/unforcing function	453
	How to access the SET and RESET commands	454
	How to access the masking/unmasking of an event function	455
	How to Access the Reactivation of Outputs Command	456
	Applied outputs of a discrete module	457
Chapter 37	Diagnostic of discrete modules	459
	How to access the Diagnostics function of a discrete module	460
	How to access the Channel Diagnostics function of a discrete module	462
Chapter 38	Installation of the discrete reflex module	463
38.1	General presentation of discrete reflex module	464
	General description of the reflex discrete module	465
	Description of the reflex discrete module	466
38.2	Configuration of the reflex discrete module	467
	Configuration of the Reflex Discrete Module	468
	Description of the reflex function configuration editor	469
	How to assign and then configure a reflex function	471
	How to set the configuration parameters of a reflex function	472
	How to associate an event with a virtual output	473

38.3	Reflex function blocks	475
	Function block : Direct	476
	Reflex function block : Combinational	477
	Reflex function block: Operation timer	479
	Reflex function block: Idle timer	480
	Reflex function block: Operation-idle timer	481
	Reflex function block: 2 value operation timer	483
	Reflex function block: Operation-idle time with value selection	486
	Reflex function block: Retriggerable monostable.	489
	Reflex function block: Monostable with time delay	490
	Reflex function block: 2 value monostable.	492
	Reflex function block: Oscillator.	494
	Reflex function block: D flip-flop.	495
	Reflex function block: T flip-flop	497
	Reflex Function Block: 2 Threshold Counter	499
	Reflex function block: Single electronic CAM	501
	Reflex function block: 1 threshold intervalometer	503
	Reflex function block: Burst	505
	Reflex function block: PWM (Pulse Width Modulation)	506
	Reflex function block: Detection of underspeed.	508
	Reflex function block: Speed monitoring	510
	Reflex function block: Type 1 command-check	513
	Reflex function block: Type 2 command-check	515
	Reflex function block: Command-counting	517
	Reflex function block: Fault Signaling	519
38.4	Modification of internal values using MOD_PARAM	521
	Modification of the internal values using MOD_PARAM function	521
Glossary	523
Index	525

Safety Information

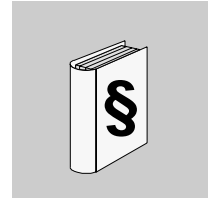

Important Information

NOTICE

Read these instructions carefully, and look at the equipment to become familiar with the device before trying to install, operate, or maintain it. The following special messages may appear throughout this documentation or on the equipment to warn of potential hazards or to call attention to information that clarifies or simplifies a procedure.



The addition of this symbol to a Danger or Warning safety label indicates that an electrical hazard exists, which will result in personal injury if the instructions are not followed.



This is the safety alert symbol. It is used to alert you to potential personal injury hazards. Obey all safety messages that follow this symbol to avoid possible injury or death.

DANGER

DANGER indicates an imminently hazardous situation which, if not avoided, **will result in** death or serious injury.

WARNING

WARNING indicates a potentially hazardous situation which, if not avoided, **can result in** death or serious injury.

 **CAUTION**

CAUTION indicates a potentially hazardous situation which, if not avoided, **can result in** minor or moderate injury.

CAUTION

CAUTION, used without the safety alert symbol, indicates a potentially hazardous situation which, if not avoided, **can result in** equipment damage.

PLEASE NOTE

Electrical equipment should be installed, operated, serviced, and maintained only by qualified personnel. No responsibility is assumed by Schneider Electric for any consequences arising out of the use of this material.

A qualified person is one who has skills and knowledge related to the construction and operation of electrical equipment and its installation, and has received safety training to recognize and avoid the hazards involved.

About the Book

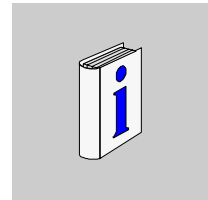

At a Glance

Document Scope

This manual describes the hardware and software implementation of Discrete modules for Premium and Atrium PLCs.

Validity Note

This documentation is valid from Unity Pro v6.0.

Product Related Information

WARNING

UNINTENDED EQUIPMENT OPERATION

The application of this product requires expertise in the design and programming of control systems. Only persons with such expertise should be allowed to program, install, alter, and apply this product.

Follow all local and national safety codes and standards.

Failure to follow these instructions can result in death, serious injury, or equipment damage.

User Comments

We welcome your comments about this document. You can reach us by e-mail at techcomm@schneider-electric.com.

Hardware installation of the Discrete I/O modules



In This Chapter

This part presents the range of Discrete I/O modules on the Premium PLC.

What's in this Part?

This part contains the following chapters:

Chapter	Chapter Name	Page
1	General overview of discrete I/O modules	19
2	General rules for implementing Discrete I/O modules	31
3	Fault processing for Discrete I/O modules	55
4	TSX DEY 08D2 input module	67
5	TSX DEY 16D2 Discrete input module	73
6	TSX DEY 16D3 Discrete input module	81
7	TSX DEY 16A2 Discrete input module	87
8	TSX DEY 16A3 Discrete input module	97
9	TSX DEY 16A4 Discrete input module	103
10	TSX DEY 16A5 Discrete input module	109
11	The TSX DEY 16FK Discrete input module	115
12	The TSX DEY 32D2K Discrete input module	125
13	TSX DEY 32D3K Discrete input module	131
14	TSX DEY 64D2K Discrete input module	137
15	TSX DSY 08T2 output module	143
16	TSX DSY 08T22 Discrete output module	149
17	TSX DSY 08T31 Discrete output module	155
18	TSX DSY 16T2 Discrete output module	161
19	TSX DSY 16T3 Discrete output module	167
20	TSX DSY 08R5 Discrete output module	173
21	TSX DSY 08R4D Discrete output module	181

Chapter	Chapter Name	Page
22	TSX DSY 08R5A Discrete output module	189
23	TSX DSY 16R5 Discrete output module	195
24	TSX DSY 08S5 Discrete output module	201
25	TSX DSY 16S5 Discrete output module	207
26	TSX DSY 16S4 Discrete output module	213
27	TSX DSY 32T2K Discrete output module	219
28	TSX DSY 64T2K Discrete output module	225
29	TSX DMY 28FK Discrete mixed I/O module	231
30	TSX DMY 28RFK Discrete mixed I/O module	239
31	TELEFAST 2 Connection Interface Links for the Discrete I/O Modules	249
32	Implementation of safety modules	343

General overview of discrete I/O modules

1

Overview

This chapter gives a general introduction to the Discrete I/O modules.

What's in this Chapter?

This chapter contains the following topics:

Topic	Page
General description of the Discrete I/O modules	20
Physical description of Discrete modules with screw terminal block connection	21
Physical description of Discrete modules with HE10 connectors	22
Catalog of Discrete input modules.	23
Catalog of Discrete output modules	25
Catalog of Discrete mixed I/O modules.	29

General description of the Discrete I/O modules

At a Glance

The Discrete I/O modules of the Premium range are standard format modules (occupying one single position), equipped with either a **HE10** connector, or a screw terminal block (**TSX BLY 01**).

For modules fitted with **HE10** type connector outputs, a series of products known as TELEFAST 2 (*see page 249*) are available that enable Discrete input/output modules to be quickly connected to operational parts.

A wide range of Discrete inputs and outputs make it possible to meet the following requirements:

- functional: direct or alternating I/Os, positive or negative logic,
- modularity: 8, 16, 32 or 64 channels/modules.

Inputs

Inputs receive signals from the sensors and carry out the following functions:

- acquisition,
- adaptation,
- galvanic insulation,
- filtering,
- protection against interference.

Outputs

Outputs store the orders given by the processor, in order to control pre-actuators via decoupling and amplification circuits.

Physical description of Discrete modules with screw terminal block connection

At a Glance

The following is a physical description of Discrete I/O modules with screw terminal block connection.

Illustration

The I/O modules are housed in plastic cases which provide IP20 protection for all the electronic parts.

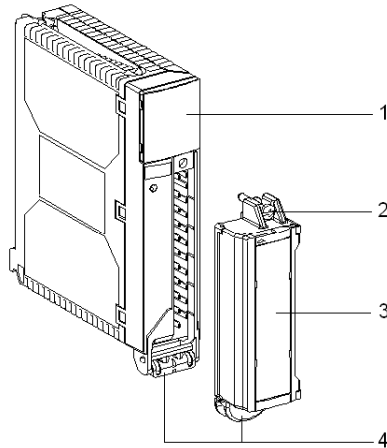

Elements

The following table describes the different elements of the Discrete I/O modules with screw terminal block connection.

Number	Description
1	Module display and diagnostics block.
2	Removable screw terminal block for directly connecting I/Os to the sensors and pre-actuators (Reference: TSX BLY 01). Certain output modules contain integrated fuses which are accessible from the front when the terminal block is removed.
3	Swing door for access to the block's screws and also acting as a marking label display area.
4	Rotating base comprising the locating device.

NOTE: the terminal blocks are supplied separately.

Physical description of Discrete modules with HE10 connectors

At a Glance

The following is a physical description of Discrete I/O modules with **HE10** connectors.

Illustration

The I/O modules are housed in plastic cases which provide IP20 protection for all the electronic parts.

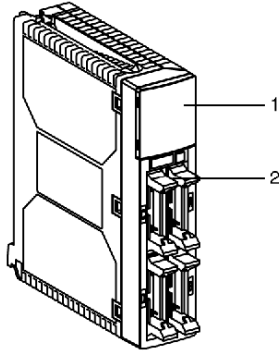

Elements

The following table describes the different elements of the Discrete I/O modules with **HE10** connectors.

Number	Description
1	Module display and diagnostics block.
2	HE10 connector, with a protective cover. They are used to connect I/Os to the sensors and pre-actuators either directly or via TELEFAST 2 (<i>see page 249</i>) connection bases.

Catalog of Discrete input modules.

At a Glance

The following is a presentation of Discrete Input modules with connection by screw terminal block or **HE10** connectors.

Catalog

The following table provides a catalog of Discrete input modules with screw terminal block connection.

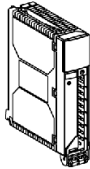
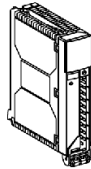
Type of module	Inputs with screw terminal block connection					
Illustration	Discrete input module 			Discrete input module 		
Number of channels	8 inputs	16 inputs				
Range	24 VDC	48 VDC	24 VAC 24 VDC	48 VAC	100..120 VAC	200..240 VAC
Insulation	Insulated inputs					
IEC 1131-2 compliance	Type 2 (1)					
Logic	Positive		Negative	-		
Proximity sensor compatibility	2 wire DC and 3 wire PNP proximity sensor (IEC 947-5-2 standard compliant)		2 wire DC and 3 wire PNP proximity sensor (IEC 947-5-2 standard compliant)			
			2 wire AC proximity sensor (IEC 947-5-2 standard compliant)			
Filtering	4 ms integrated		Integrated, 50 or 60 Hz Network			
Connections	Screw terminal block					

TSX** reference number	DEY 08D2	DEY 16D2	DEY 16D3	DEY 16A2	DEY 16A3	DEY 16A4	DEY 16A5
Legend:							
(1) For the TSX DEY 16A2 module, type 2 compliance is only for the 24 VAC version.							

Catalog

The following table provides a catalog of Discrete input modules with **HE10** connectors.

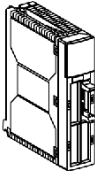
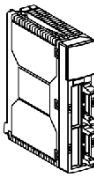
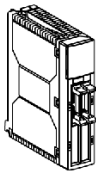
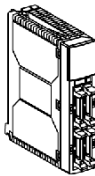
Type of module	Inputs with HE10 connectors			
Illustration	Discrete input module 	Discr. I. Mod. 	Discr. I. Mod. 	Discr. I. Mod. 
Number of channels	16 fast inputs	32 inputs		64 inputs
Range	24 VDC		48 VDC	24 VDC
Insulation	Insulated inputs			
IEC 1131-2 compliance	Type 1		Type 2	Type 1
Logic	Positive			
Proximity sensor compatibility <i>(see page 50)</i>	2 wire proximity sensor 3 wire PNP proximity sensor			
Filtering Programmable filtering Latching Event	0.1..7.5 ms in 0.5 ms steps yes yes yes	4 ms fixed		
Connections	HE10 connectors			
TSX** reference number	DEY 16FK	DEY 32D2K	DEY 32D3K	DEY 64D2K

Catalog of Discrete output modules

At a Glance

The following is the catalog of transistor, relay and bidirectional triode thyristor Discrete output modules with screw terminal block connection, and the catalog of Discrete transistor output modules with **HE10** connectors.

Catalog

The following table provides a catalog of transistor Discrete output modules with screw terminal block connection.

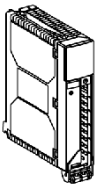
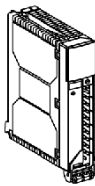
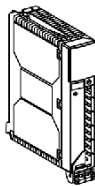
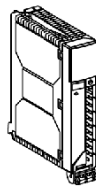
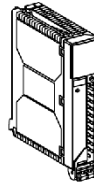
Type of module	Transistor outputs with screw terminal block connection					
Illustration	Discrete output module 	Discrete output module 	Discrete output module 	Discrete output module 	Discrete output module 	
Number of channels	8 outputs			16 outputs		
Range	24 VDC		48 VDC	24 VDC	48 VDC	
Insulation	Insulated outputs					
Current	0.5 A	2 A	1 A	0.5 A	0.25 A	
IEC 1131-2 compliance	Yes					
Protection	Outputs protected against short-circuits and overloads, with automatic or controlled reactivation, and with fast electromagnet demagnetization circuits.					
Fallback	Configurable fallback of outputs, permanent monitoring of output control, and reset of outputs in the event of detection of an internal fault.					
Logic	Positive					
Response time	1 ms	0.2 ms	0.3 ms	1 ms	1 ms	
Connections	Screw terminal block					
TSX** reference number	DSY 08T2	DSY 08T22	DSY 08T31	DSY 16T2	DSY 16T3	

Catalog

The following table provides a catalog of relay Discrete output modules with screw terminal block connection.

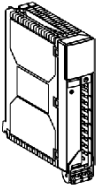
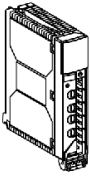
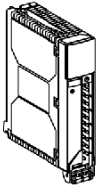
Type of module	Relay outputs with screw terminal block connection			
Illustration	Discrete module 	Discrete output module 		Discrete module 
Number of channels	8 outputs			16 outputs
Range	12..24 VDC or 24..240 VAC	24..130 VDC	24..48 VDC or 24..240 VAC	12..24 VDC or 24..240 VAC
Insulation	Outputs insulated between contact and earth			
Current	3 A	5 A		3 A
IEC 1131-2 compliance	Yes			
Protection	No protection	Interchangeable fuse protection. Output reset in the event of fault detection, reactivation once fuse is replaced.		No protection
Fallback	Configurable output fallback.			
Terminal block unlocking	Automatic output cut-off device on unlocking of terminal blocks.			
Logic	Positive/negative			
Connections	Screw terminal block			
TSX** reference number	DSY 08R5	DSY 08R4D	DSY 08R5A	DSY 16R5

Catalog

The following table provides a catalog of bidirectional triode thyristor Discrete output modules with screw terminal block connection.

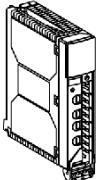
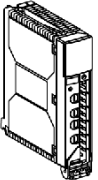
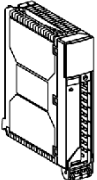
Type of module	Bidirectional triode thyristor outputs with screw terminal block connection		
Illustration	Discrete output module 	Discrete output module 	Discrete output module 
Number of channels	8 outputs	16 outputs	
Range	48..240 VAC		24..120 VAC
Insulation	Insulated outputs		
Current	2 A	1 A	
IEC 1131-2 compliance	Yes		
Protection	Interchangeable fuse protection.		Outputs not protected against short circuits or overloads. 'Fireproof' protection via non-interchangeable fuses
Fallback	Configurable output fallback.		
Terminal block unlocking	Automatic output cut-off device on unlocking of terminal blocks.		
Connections	Screw terminal block		
TSX** reference number	DSY 08S5	DSY 16S5	DSY 16S4

Catalog

The following table provides a catalog of transistor Discrete output modules with **HE10** connectors.

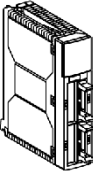
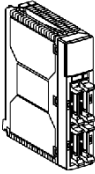
Type of module	Transistor outputs with HE10 connectors.	
Illustration	Discrete output module 	Discrete output module 
Number of channels	32 outputs	64 outputs
Range	24 VDC	
Insulation	Insulated outputs	
Current	0.1 A	
IEC 1131-2 compliance	Yes	
Protection	Outputs protected against short circuits and overloads with automatic or controlled reactivation.	
Fallback	Configurable fallback of outputs, permanent monitoring of output control, and reset of outputs in the event of detection of an internal fault.	
Logic	Positive	
Connections	HE 10 connector	
TSX** reference number	DSY 32T2K	DSY 64T2K

Catalog of Discrete mixed I/O modules.

At a Glance

The following is the catalog of Discrete mixed I/O modules with **HE10** connectors.

Catalog

The following table provides a catalog of Discrete mixed I/O modules with **HE10** connectors.

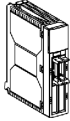
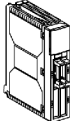
	Type of module	Transistor outputs with HE10 connectors.	
	Illustration	Discrete mixed I/O module 	Discrete mixed I/O module 
	Number of channels	16 fast inputs 12 outputs	16 fast inputs 16 event outputs
Inputs	Range	24 VDC	
	Insulation	Insulated inputs	
	IEC 1131-2 compliance	Type 1	
	Logic	Positive	
	Proximity sensor compatibility (see page 50)	2 wire proximity sensor	
	Programmable filtering	Yes (0.1..7.5 ms in 0.5 ms steps)	
	Latching	Yes	
	Event	Yes	
Outputs	Range	24 VDC	
	Insulation	Insulated outputs	
	Current	0.5 A	
	IEC 1131-2 compliance	Yes	
	Protection	Outputs protected against short-circuits and overloads, with automatic or controlled reactivation, and with fast electromagnet demagnetization circuit.	
	Fallback	Configurable output fallback. Permanent monitoring of output commands, and reset of outputs in the event of internal fault detection.	
	Logic	Positive	
	Response time	0.6 ms	
	Connections	HE10 connectors	
	TSX** reference number	DMY 28FK	DMY 28RFK

General rules for implementing Discrete I/O modules

2

Overview

This chapter presents the general rules for implementing Discrete I/O modules.

What's in this Chapter?

This chapter contains the following topics:

Topic	Page
Fitting of Discrete I/O Modules	32
Fitting a screw terminal block to a Discrete I/O module.	34
Identification of Discrete I/O Modules with Screw Terminal Block Connections	35
Identification of Discrete I/O Modules with HE10 Connectors	37
Choice of direct current power supply for sensors and pre-actuators associated with Discrete I/O modules	39
Precautions and General Rules for Wiring with Discrete I/O Modules	40
Means of Connecting Discrete I/O Modules: Connecting Screw Terminal Block Modules	44
Connecting Discrete I/O Modules: HE10 Connector Modules	46
Connecting Discrete I/O Modules to TELEFAST Interfaces Using an HE10 Connector	48
Sensor/Input Compatibility and Pre-Actuator/Output Compatibility	50

Fitting of Discrete I/O Modules

At a Glance

All Premium Discrete I/O modules are of standard format. Fitting operations (installation, assembly and disassembly) are described below.

Installation

The Discrete I/O modules, powered by the rack bus, can either be positioned on the standard rack or on an extendable rack. They can be safely handled without turning off the rack power supply.

The diagram below shows Discrete I/O modules installed in the rack.

Standard rack

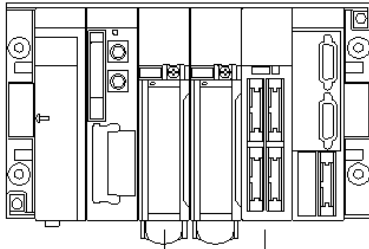

Extendable rack

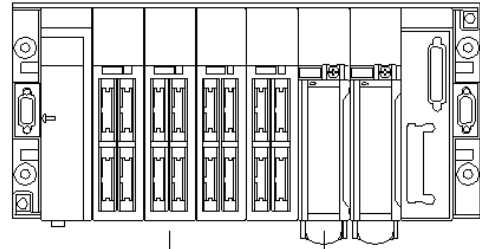

Connector modules

Terminal block modules

Assembly/Disassembly

The following table shows the procedure for mounting the Discrete I/O modules in the rack.

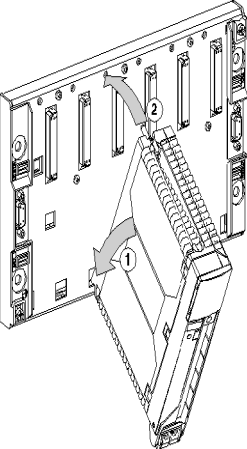
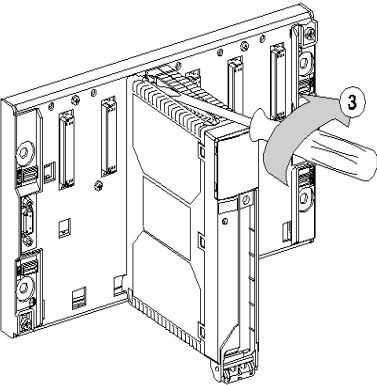
Step	Action	Illustration
1	Position the locating pins situated at the rear of the module (on the lower section) in the corresponding slots in the rack.	Step 1 and 2
2	Pivot the module towards the top of the rack so as to engage the rack connector.	
3	Tighten the fastening screws of the upper section of the module so as to firmly attach the module to the rack (torque setting: 2.0 N.m). Warning: If this screw is left untightened, the module will not remain in position in the rack.	Step 3
Note: Assembling and disassembling modules is performed when: sensor and pre-actuator voltage is switched off, and the terminal block is disconnected		

Fitting a screw terminal block to a Discrete I/O module.

At a Glance

All Premium Discrete I/O modules with screw terminal block connection require the latter to be connected to the module. Fitting operations (assembly and disassembly) are described in the following table.

Assembly/Disassembly

The following table shows the procedure for assembling the screw terminal block onto a Discrete I/O module.

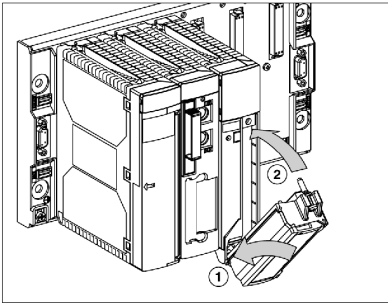
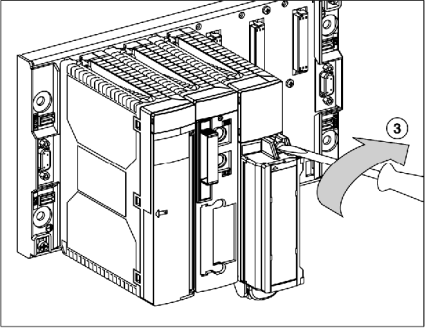
Step	Action	Illustration
1	With the module in position in the rack, place the terminal block on the module as shown opposite.	<p data-bbox="622 553 746 574">Step 1 and 2</p> 
2	Pivot the terminal block so as to bring it to the engaged position on the module.	
3	Tighten the fastening screws of the upper section of the terminal block so as to firmly attach the terminal block to the module (torque setting: 2.0 N.m).	<p data-bbox="622 914 691 935">Step 3</p> 
Note:	<p>The first time a screw terminal block is mounted on a module which takes this type of connection, the terminal block is coded according to the type of module on which it is assembled. Coding is performed by transferring two encoded pins from the module to the terminal block. This mechanical coding then inhibits any use of the terminal block with a different module type.</p> <p>The code is transferred automatically during step 1.</p>	

Identification of Discrete I/O Modules with Screw Terminal Block Connections

At a Glance

Discrete I/O modules with screw terminal block connection are identified by the markings on the lid of the front section of the module, and the labels located on the terminal block.

Illustration

The following diagram illustrates the identification of the Discrete I/O modules with screw terminal block connection.

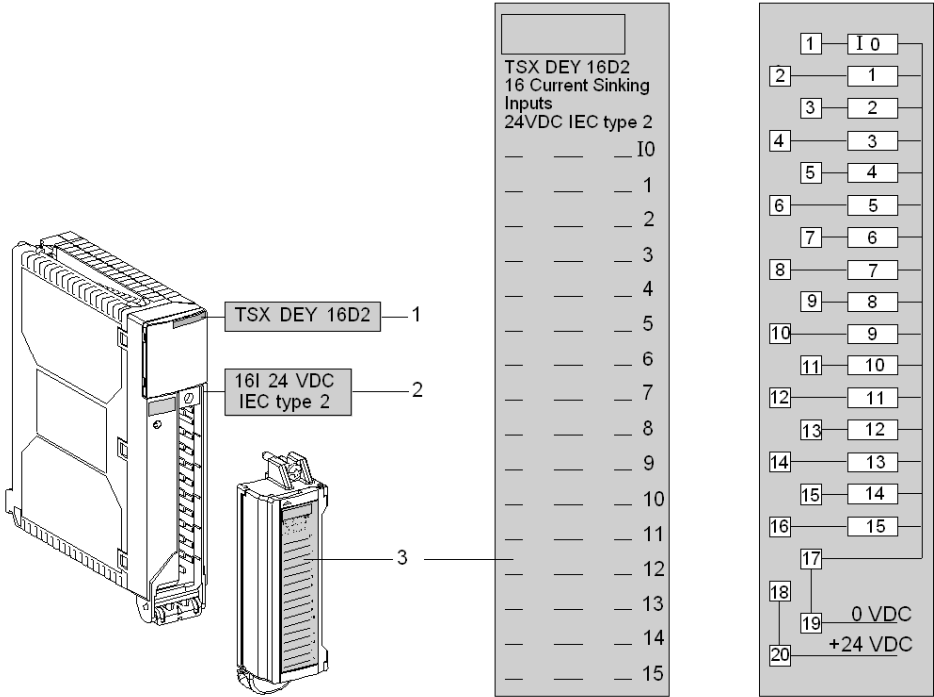

Description

The following table shows the different elements for the identification of Discrete I/O modules, and gives an explanation for each one.

Marking	Location	Type of identification
1	On module display block	A marking giving the module reference number.
2	Under the module display block	A marking indicating the module's characteristics.
3	On the terminal block	A removable label (supplied with the module), to be placed inside the door, printed on both sides and displaying the following indications: <ul style="list-style-type: none">● external view (door closed):<ul style="list-style-type: none">● the reference number of the module,● the number of channels,● a box for entering the module's position number (address),● the designation of each channel (symbol).● internal view (door open):<ul style="list-style-type: none">● the wiring diagram for inputs and outputs with the number of channels and connection terminals.

Identification of Discrete I/O Modules with HE10 Connectors

At a Glance

Discrete I/O modules with **HE10** connectors are identified by the markings on the lid of the front section of the module.

Illustration

The following diagram illustrates the identification of **TSX DEY••/DSY••** I/O modules with **HE10** connectors.

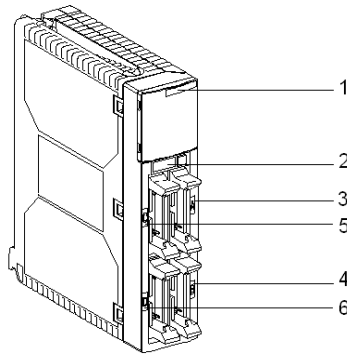

Description

The following table shows the different elements for the identification of **TSX DEY••/DSY••** I/O modules, and gives an explanation for each one.

Marking	Location	Type of identification
1	On module display block	A marking giving the module reference number.
2	Under the module display block	A marking indicating the module's characteristics.
3	Under the module display block	A marking giving the corresponding channel addresses: ● channels 0 to 15 of the module (I or Q).
4	Under the module display block	A marking giving the corresponding channel addresses: ● channels 16 to 31 of the module (I or Q).
5	Under the module display block	A marking giving the corresponding channel addresses: ● channels 32 to 47 of the module (I or Q).
6	Under the module display block	A marking giving the corresponding channel addresses: ● channels 48 to 63 of the module (I or Q).

Illustration

The following diagram illustrates the identification of **TSX DEY 32D3K** input modules and **TSX DMY 28FK/28RFK** mixed I/O modules with **HE10** connectors.

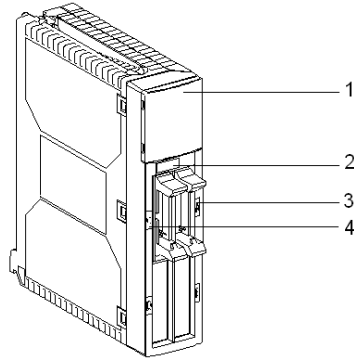

Description

The following table shows the different elements for the identification of **TSX DEY 32D3K** input modules and **TSX DMY 28FK/28RFK** mixed I/O modules, and gives an explanation for each one.

Marking	Location	Type of identification
1	On module display block	A marking giving the module reference number.
2	Under the module display block	A marking indicating the module's characteristics.
3	Under the module display block	A marking giving the corresponding channel addresses: <ul style="list-style-type: none"> input channels 0 to 15 of TSX DEY 32D3K or TSX DMY 28FK/28RFK modules (I).
4	Under the module display block	A marking giving the corresponding channel addresses: <ul style="list-style-type: none"> input channels 16 to 31 of the TSX DEY 32D3K module (I). output channels 16 to 27 of TSX DMY 28FK/28RFK modules (Q).

Choice of direct current power supply for sensors and pre-actuators associated with Discrete I/O modules

At a Glance

The following is a presentation of precautions for choosing sensors and pre-actuators associated with Discrete I/O modules.

External direct current power supplies

When using an external 24 VDC direct current power supply, it is advised to use either:

- regulated power supplies,
- non-regulated power supplies but with the following filtering:
 - 1000 μ F/A with full-wave single phase rectification and 500 μ F/A with tri-phase rectification,
 - 5% maximum peak to peak ripple,
 - maximum voltage variation: -20% to +25% of the nominal voltage (including ripple).

NOTE: rectified power supplies with no filtering are prohibited.

Ni-Cad battery power supplies

This type of power supply can be used to power sensors and pre-actuators and all associated I/Os that have a normal operating voltage of 30 VDC maximum.

While being charged, this type of battery can reach, for a duration of one hour, a voltage of 34 VDC. For this reason, all I/O modules with an operating voltage of 24 VDC can withstand this voltage (34 VDC) for up to one hour every 24 hours. This type of operation entails the following restrictions:

- at 34 VDC, the maximum current withstood by the outputs must under no circumstances exceed the maximum current defined for a voltage of 30 VDC,
- temperature downgrading imposing the following restrictions:
 - 80% of I/Os at 1 up to 30° C,
 - 50% of I/Os at 1 up to 60° C.

Precautions and General Rules for Wiring with Discrete I/O Modules

At a Glance

Discrete I/Os feature protective measures which ensure a high resistance to industrial environmental conditions. Certain rules, shown below, must nevertheless be respected.

External power supplies for sensors and pre-actuators

External sensor and pre-actuator power supplies associated with Discrete I/O modules must use quick-blow fuses against short-circuits and overloads.

For **HE10** connector Discrete I/O modules, the sensor/pre-actuator power supply must be linked to each connector, except in the event where the corresponding channels are not in use and are not assigned to any task.

NOTE: in the event that the 24 VDC installation is not carried out according to VLSV (very low safety voltage) standards, the 24 VDC power supplies must have the 0V linked to mechanical ground, which is in turn linked to the ground as close as possible to the power supply. This restriction is necessary for personnel safety in the event of a power phase coming into contact with the 24 VDC supply.

Inputs

Recommendations for use concerning Discrete I/O module inputs are as follows:

- for fast input modules (**TSX DEY 16 FK/DMY 28FK/DMY 28RFK**):
 - in the event that 24 VDC direct current inputs are used, it is recommended to adapt the filtering time to the required function,
 - in order for bounces not to be taken into account upon closure of contacts, it is not advisable to use sensors with mechanical contact outputs if the filtering time is reduced to under 3 ms,
 - for faster operation, the use of direct current inputs and sensors is recommended, as alternating current inputs have a much higher response time.

- for 24 VDC inputs and line coupling with an alternating current network:
 - operation can be disturbed if the coupling between cables relaying an alternating current and cables relaying signals intended for direct current inputs is too large. This is illustrated in the following circuit diagram. When the input contact is open, an alternating current exceeding the cable's interference capacities may generate a current in the input which might cause it to be set to 1.

Diagram

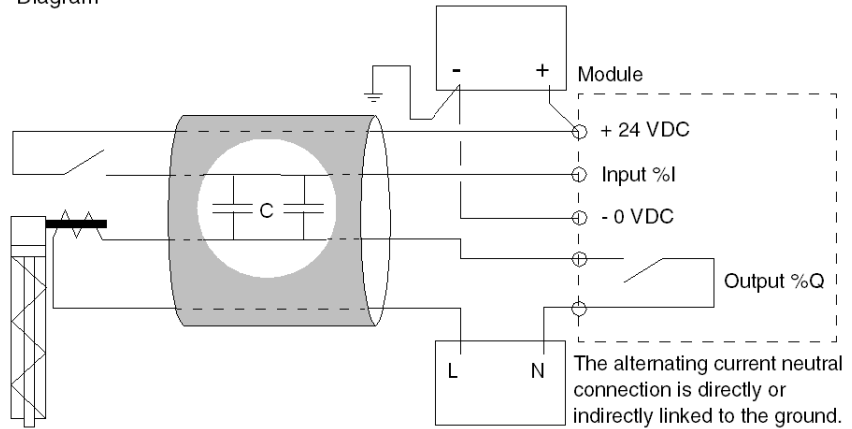

- the line capacity values that must not be exceeded, for a 240 VCA/50 Hz line coupling, are given in the summary table at the end of this paragraph. For a coupling with a different voltage, the following formula can be applied:
 Acceptable capacity = (Capacity at 240 VAC x 240) / line voltage

- for 24 to 240 VAC inputs and line coupling:
 - in this case, when the line that controls the input is open, the current passes according to the coupling capacity of the cable (see circuit diagram below).

Diagram

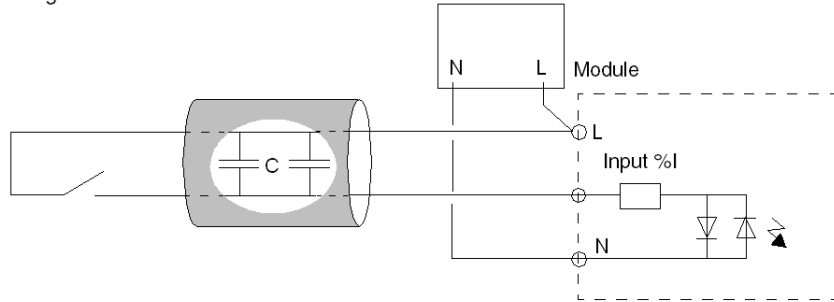

- the line capacity values that must not be exceeded are given in the summary table at the end of this paragraph.

The following summary table shows the acceptable line capacity values.

Module	Maximum coupling capacity
24 VDC inputs	
TSX DEY 32 / TSX DEY 64D2K	25 nF (1)
TSX DEY 16D2	45 nF (1)
TSX DEY 16FK / TSX DMY 28FK / TSX DMY 28RFK	10 nF (1) (2) 30 nF (1) (3) 60 nF (1) (4)
24 to 240 VAC inputs	
TSX DEY 16A2	50 nF
TSX DEY 16A3	60 nF
TSX DEY 16A4	70 nF
TSX DEY 16A5	85 nF
Legend:	
(1)	Max. admissible coupling capacity with 240 VAC / 50 Hz line
(2)	Filtering = 0.1 ms
(3)	Filtering = 3.5 ms
(4)	Filtering = 7.5 ms

Outputs

Recommendations for use concerning Discrete I/O module outputs are as follows:

- it is recommended to segment starts, protecting each one with a quick-blow fuse, if currents are high,
- wires of a sufficient diameter should be used to avoid drops in voltage and overheating.

Cable routing

Precautions for use to be taken concerning the wiring system are as follows:

- in order to reduce the number of alternating couplings, power circuit cables (power supplies, power switches, etc.) must be separated from input cables (sensors) and output cables (pre-actuators) both inside and outside the equipment,
- outside the equipment, cables leading to inputs / outputs should be placed in covers that make them easily distinguishable from those containing wires relaying high energy levels. They should also be placed preferably in separate grounded metal cableways. These various cables must be routed at least 100 mm apart.

Means of Connecting Discrete I/O Modules: Connecting Screw Terminal Block Modules

At a Glance

Discrete I/O module terminal blocks feature an automatic code transfer device activated on first use. This allows fitting errors to be avoided when replacing a module. This coding guarantees electrical compatibility by module type.

Description of the screw terminal block

Every terminal block can receive bare wires or wires with terminations or spade terminals.

The capacity of each terminal is:

- minimum: 1 x 0.2 mm² wire (AWG 24) without termination,
- maximum: 1 x 2 mm² wire without termination or 1 x 1.5 mm² with termination.

Illustration of the termination and the spade terminal.



(1) 5.5 mm maximum.

The maximum capacity of the terminal block is 16 x 1 mm² wires (AWG) + 4 x 1.5 mm² wires (AWG).

Screw clamps come with slots for the following types of screwdriver:

- Pozidriv No. 1,
- 5 mm diameter flat head.

Screw connection terminal blocks feature captive screws. On the supplied blocks, these screws are not tightened.

NOTE: the maximum torque for tightening connection terminal block screws is 0.8 N.m

NOTE: Screw terminal blocks must be engaged or disengaged with sensor and pre-actuator voltage switched off.

The following diagram shows the method for opening the screw terminal block door.

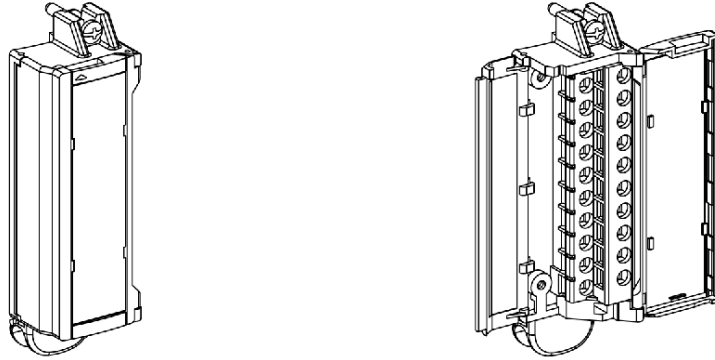

Connecting Discrete I/O Modules: HE10 Connector Modules

At a Glance

HE10 connector modules are connected to sensors, pre-actuators or terminal blocks using a pre-formed cable designed to allow the smooth and direct transition of module inputs/outputs from wire to wire.

Pre-Formed Cable TSX CDP 301 / 501

The 3-meter long TSX CDP 301 or 5-meter long TSX CDP 501 pre-formed cables consist of:

- a molded HE10 connector at one end with 20 protruding sheathed wires with a cross-section of 0.34 mm²;
- free wires at the other end, differentiated by a color code complying with DIN 47100.

NOTE: A nylon thread built into the cable allows easy-stripping of the sheath.

NOTE: HE10 connectors must be engaged or disengaged with sensor and pre-actuator voltage switched off.

The diagram below shows the connection of the pre-formed cable to the module.

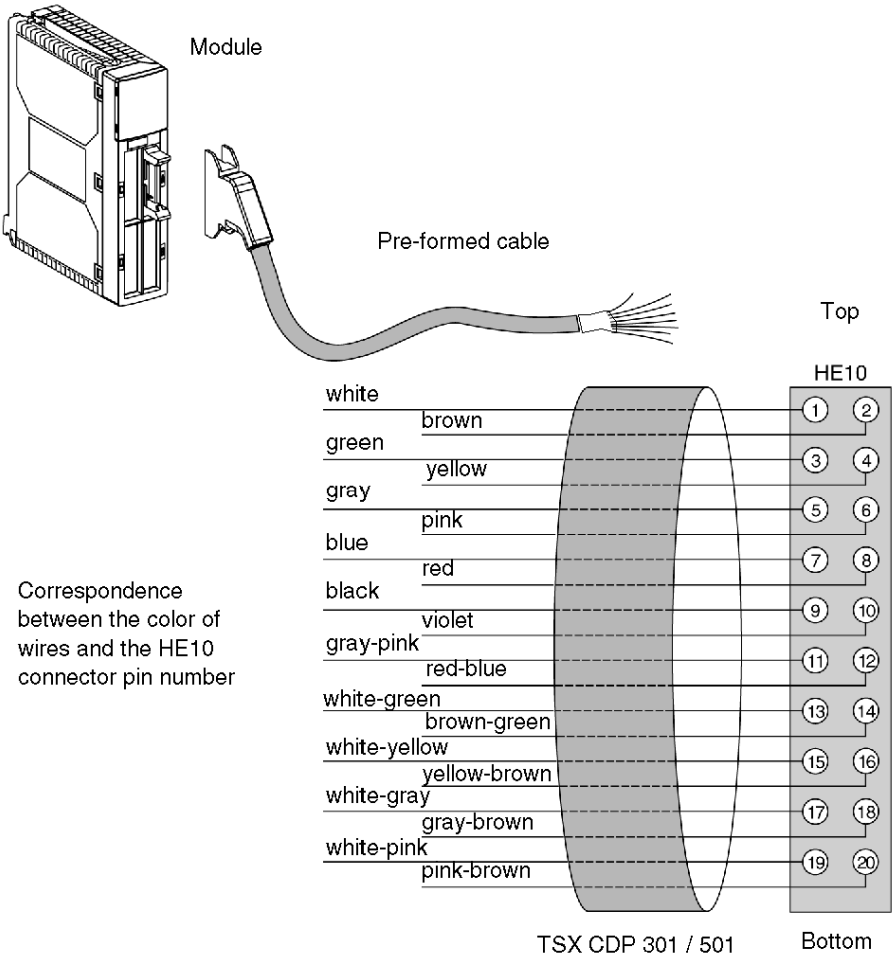

Connecting Discrete I/O Modules to TELEFAST Interfaces Using an HE10 Connector

At a Glance

Connecting discrete input/output modules to TELEFAST interfaces for connecting and adapting fast wiring HE10 connectors, is done with the aid of:

- a 28 gauge multi-stranded sheathed cable (0.08 mm²);
- a 22 gauge connection cable (0.34 mm²).

TSX CDP 102/202/302 Connection Cable

The 28 gauge connection cable (0.08 mm²) comes in three different lengths:

- 3 ft 3.4 in length: TSX CDP 102,
- 6 ft 6.8 in length: TSX CDP 202,
- 9 ft 10.2 in length: TSX CDP 302.

This cable is made up of 2 HE10 connectors and a multi-stranded sheathed ribbon cable, where each wire has a cross-section area of 0.08 mm².

Given the small area of each of the wires, you are advised to only use it for low current inputs or outputs (< 100 mA per input or output).

TSX CDP 053/103/203/303/503 Connection Cable

The 22 gauge connection cable (0.34 mm²) comes in five different lengths:

- 1 ft 7.7 in length: TSX CDP 053,
- 3 ft 3.4 in length: TSX CDP 103,
- 6 ft 6.8 in length: TSX CDP 203,
- 9 ft 10.2 in length: TSX CDP 303,
- 16 ft 5 in length: TSX CDP 503.

This cable is made up of 2 sheathed HE10 connectors, and a cable with a cross-section of 0.34 mm², which can take higher currents (> 500 mA).

Illustration

The illustration below shows the two types of connection to the TELEFAST interface via multi-strand cable or other cable.

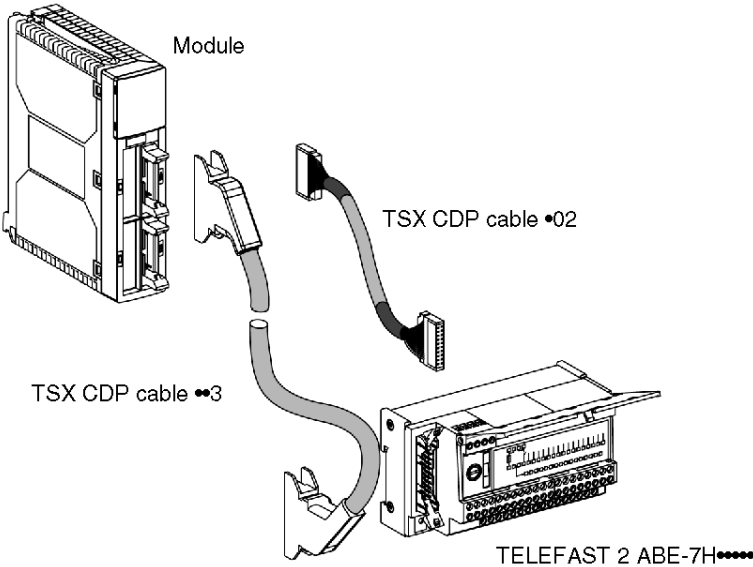

NOTE: Check the consistency between the rating of the fuse on board the TELEFAST 2 and the fuse which is to be used on the inputs/outputs (see Connecting modules).

Sensor/Input Compatibility and Pre-Actuator/Output Compatibility

At a Glance

The following is a description of compatibility between sensors and Discrete module inputs, and between pre-actuators and Discrete module outputs.

Sensor/Input Compatibility

- Compatibility between 3-wire sensors and 24 and 48 VDC inputs:
 - 3-wire sensors and IEC 1131-2 compliant type 1 and type 2 positive logic (sink) inputs: all 3-wire PNP inductive or capacitive proximity sensors and photo-electric detectors which have an operating voltage of 24 and 48 VDC are compatible with all positive logic inputs;

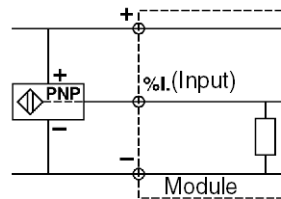

- 3-wire sensors and negative logic (source) inputs: all NPN 3-wire inductive or capacitive proximity sensors and photo-electric detectors which have an operating voltage of 24 VDC are compatible with negative logic inputs from the Premium range.

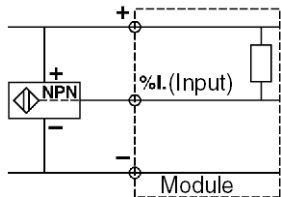

- Compatibility between 2-wire sensors and 24 VDC inputs:
 - 2-wire sensors and IEC 1131-2 compliant type 1 positive logic (sink) inputs: all proximity sensors or other 2-wire sensors with an operating voltage of 24 VDC and with the characteristics described below are compatible with all type 1 positive logic 24 VDC inputs from the Premium range:
Voltage drop in closed state: ≤ 7 V,
minimum switched current: ≤ 5 mA,
residual current in open state: ≤ 1.5 mA.

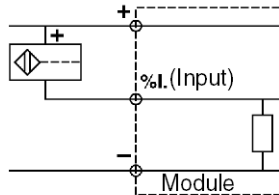

- 2-wire sensors and IEC 1131-2 compliant type 2 positive logic (sink) inputs: all 2-wire proximity sensors with an operating voltage of 24 and 48 VDC and which are IEC 947-5-2 compliant are compatible with all type 2 positive logic 24 and 48 VDC inputs;

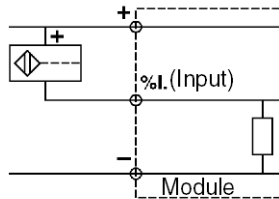

- 2-wire sensors and negative logic (source) inputs: all proximity sensors or other 2-wire sensors with an operating voltage of 24 VDC direct current and with the characteristics described below are compatible with all negative logic 24 VDC inputs from the Premium range:
Voltage drop in closed state: ≤ 7 V,
minimum switched current: ≤ 5 mA,
residual current in open state: ≤ 1.5 mA.

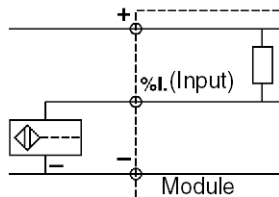

- Compatibility between 2-wire sensors and 24/48/100..120/200..240 VAC inputs:
 - all IEC 947-5-2 compliant 2-wire AC proximity sensors able to withstand 100...120 VAC are compatible with all type 2 IEC 1131-2 compliant 110..120 VAC inputs,
 - all IEC 947-5-2 compliant 2-wire AC proximity sensors and other sensors able to withstand 200..240 VAC are compatible with all type 2 IEC 1131-2 compliant 220..240 VAC inputs from the Premium range of between 220..240 VAC.

The following table provides a summary of compatibility between sensors and Discrete I/O module inputs.

Types of proximity sensor	Types of input				
	24 VDC Type 1 Positive logic	24/48 VDC Type 2 Positive logic	24 VDC Negative logic	24/48 VAC 100..120 VAC Type 2	200..240 VAC Type 2
All PNP-type 3-wire (DC) proximity sensors	Compatibility	Compatibility	-	-	-
All NPN-type 3-wire (DC) proximity sensors	-	-	Compatibility	-	-
Telemecanique or other brand 2-wire (DC) proximity sensors with the following characteristics: Voltage drop in closed state <= 7 V Minimum switched current <= 2.5 mA Residual current in open state <= 1.5 mA	Compatibility	Compatibility	Compatibility	-	-
2-wire (AC/DC) proximity sensor	-	Compatibility	-	Compatibility	Compatibility (1)
2-wire (AC) proximity sensor	-	-	-	Compatibility	Compatibility (1)
Legend:					
(1)	In the nominal voltage range of 220..240 VAC.				
DC	DC voltage operation.				
AC	AC voltage operation.				
AC/DC	AC or DC voltage operation.				

Compatibility of Pre-Actuators with Outputs

- Compatibility of DC pre-actuators and outputs:
 - comply with the output's maximum current and maximum switching frequency as specified in the table of characteristics,
 - where low consumption pre-actuators are used, special attention must be paid to the leakage current of the idle output, to ensure that the following inequation is satisfied:
 $I_{\text{nominal}} \geq (50 \times I_{\text{leakage}})$
 given that:
 I_{nominal} = current consumed by the pre-actuator,
 I_{leakage} = leakage current in idle output state.
- Compatibility of tungsten filament lamps and transistor outputs (static current):
 - for outputs with protection against short circuits, the maximum power of the tungsten filament lamps specified in the table of characteristics must be complied with. If not, the lamp's pick-up current might cause a tripped output at the time of power-up.
- Compatibility of AC pre-actuators and relay outputs:
 - Inductive AC pre-actuators have a pick-up current of up to 10 times their holding current for a duration of $2/F$ seconds (F = alternating current frequency). Relay outputs are therefore set to withstand these conditions (AC14 and AC15). The table of characteristics for relay outputs gives the maximum authorized running power (in AV) according to the number of operations.

CAUTION

THERMAL CURRENT OVERHEATING RELAY

Do not use a relay for currents exceeding its defined thermal current capability.

Failure to follow these instructions can result in injury or equipment damage.

- Compatibility of lamps and bidirectional triode thyristor outputs:
 - ensure that the maximum power is equal to:
 $U \times I_{\text{max}}$

- Compatibility of AC pre-actuators with relay bidirectional triode thyristor outputs:
 - comply with the specified maximum current,
 - where low consumption pre-actuators are used, special attention must be paid to the leakage current of the idle output, to ensure that the following inequation is satisfied:
 $I_{\text{nominal}} \geq (50 \times I_{\text{leakage}})$
given that:
 I_{nominal} = current consumed by the pre-actuator,
 I_{leakage} = leakage current in idle output state.

Fault processing for Discrete I/O modules

3

Overview

This chapter presents hardware fault processing for Discrete I/O modules.

What's in this Chapter?

This chapter contains the following topics:

Topic	Page
General protective measures of Discrete I/O modules	56
Discrete Inputs/Outputs fault display	57
Discrete Inputs/Outputs Fault Diagnostics	60
Checking the Discrete Input / Output connection	64

General protective measures of Discrete I/O modules

At a Glance

The following is a description of the general protective measures integrated into the channels of Discrete I/O direct current modules.

DC outputs

Every transistor output (except where specifically labeled "Non-Protected"), features a protective device which allows the following to be detected when an output is active:

- an overload or short circuit; failures such as these cause the output to be deactivated (tripped) and the failure to be indicated on the display on the front panel of the module (the LED corresponding to the channel flashes, the **I/O** error LED comes on),
- a polarity reversal; a failure such as this causes the power supply to short circuit without damaging the module. In order to obtain optimal protection, a quick-blow fuse must be installed on the power supply and upstream from the pre-actuators,
- an inductive overload; each output is individually protected against inductive overloads and has a fast electro-magnet demagnetization circuit using a zener diode which allows the mechanical cycle of certain fast machines to be reduced.

DC inputs

24 and 48 VDC dc inputs are of constant current type. For any input voltage in excess of 11 V (for 24 VDC inputs) or 20 V (for 48 VDC inputs), the input current remains constant.

This characteristic has the following advantages:

- guaranteed minimum current in active state in accordance with IEC standards,
- limited consumed current when input voltage increases, to avoid the module overheating unnecessarily,
- reduced consumed current to the power supply sensor supplied by the PLC power supply or a process power supply.

Discrete Inputs/Outputs fault display

At a Glance

The Discrete I/O modules are equipped with a display block featuring LEDs that allow the module's operating modes and any failures to be displayed.

Illustration

The following diagram shows the position of the three fault display LEDs, on the front panel of the Discrete I/O modules.

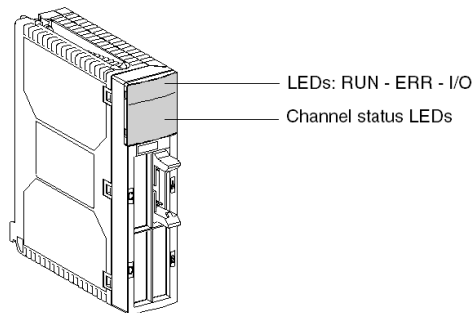

Description

The following table explains how the LEDs located on the Discrete I/O display block operate.

LEDs	Continually lit	Flashing	Off
RUN (green)	Module operating normally.	-	Module faulty or off.
ERR (red)	Internal error: Module failure.	Communication error if RUN LED is on. Module non-configured if RUN LED is off.	No internal error.
I/O (red)	External fault: overload, short circuit, sensor/pre-actuator voltage error.	Terminal block error.	No external error.
Channel status	Channel at 1	Channel error, overload or short circuit.	Channel at 0

NOTE: When the sensor power outage, the error LED of the following modules switch on and the last recorded position of the sensor is displayed by the inputs LED.

The following list gives the 24 VDC modules:

- TSX DEY 16D2
- TSX DEY 32D2K
- TSX DEY 64D2K

The following list gives the 48 VDC modules:

- TSX DEY 16D3
- TSX DEY32D3K

⚠ WARNING

CHANNEL LED INFORMATION NOT MATCHING SENSORS POSITION

After a sensor power outage:

- The I/O error LED is on.
- Do not take into account the input LEDs information (they show the last recorded position of the sensors, not their real positions).
- Check the real positions on the sensors.

Failure to follow these instructions can result in death, serious injury, or equipment damage.

Fault display blocks

There are several fault display blocks depending on the type of Discrete I/O module:

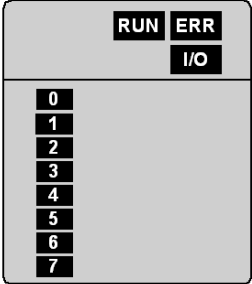
Module	Illustration	Description
8-channel modules	Fault display block 	These modules have: <ul style="list-style-type: none"> • 3 RUN - ERR - I/O module status LEDs, • 8 channel status LEDs.

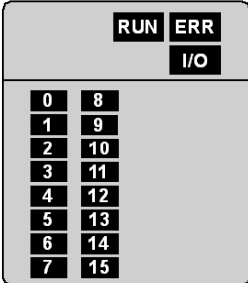
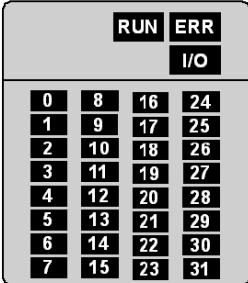
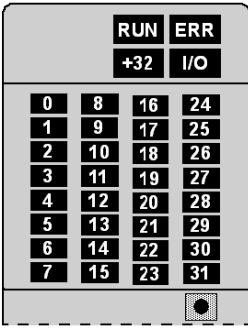
Module	Illustration	Description
16-channel modules	Fault display block 	These modules have: <ul style="list-style-type: none"> ● 3 RUN - ERR - I/O module status LEDs, ● 16 channel status LEDs.
28 and 32-channel modules	Fault display block 	These modules have: <ul style="list-style-type: none"> ● 3 RUN - ERR - I/O module status LEDs, ● 32 channel status LEDs.
64-channel modules	Fault display block 	These modules have: <ul style="list-style-type: none"> ● 3 RUN - ERR - I/O module status LEDs, ● 1 x +32 LED to display channels 32 to 36, ● 32 channel status LEDs, ● 1 switch to display channels 32 to 63.

NOTE: On a loss of power to the sensors, for TSXDEY16D2/3, TSXDEY32D2K and TSXDEY64D2K 24VDC and 48VDC input modules, when the red I/O error light is on, the status of the input lights (green) is meaningless and can be different from the current status of the module inputs. In general, the lights' status corresponds to the last valid status seen by the module before loss of power to the sensors.

Discrete Inputs/Outputs Fault Diagnostics

At a Glance

The diagnostics function detects any errors that may be in progress. Three error groups can be identified:

- internal errors,
- external errors,
- other errors.

Internal Errors

This category contains all internal module errors and all communication errors that prevent a Discrete module from operating correctly.

A communication error may be caused by a hardware error at the rack bus, or a processor or extension cable error.

External Errors

The following errors fall into this category:

- **terminal block error:** all terminal block modules contain a device for checking the presence of a terminal block in the module. Where a terminal block is missing or badly inserted in the module, the error is detected and is alerted by the flashing of the **I/O** LED on the front panel of the module,
- **overload and short-circuit:** transistor output modules contain a device for checking the load status. In the event of overload or short circuit of one or several outputs, the circuits of these will be tripped and the errors will be shown on the front panel of the module - the LEDs corresponding to the faulty outputs will flash and the red **I/O** LED will light up,
- **sensor voltage error:** all input modules contain a device for checking sensor voltage for all module channels. This device checks that sensor and module power supply voltages are of a sufficiently high level to guarantee the correct operation of the module's input channels. When sensor voltage is less than or equal to a defined threshold, the error is shown by the **I/O** LED lighting up on front panel of the module,

- **pre-actuator voltage error:** all 24/48 VDC transistor output modules contain a device for checking the pre-actuator voltage of all module channels. This device checks that pre-actuator and module power supply voltages are of a sufficiently high level to guarantee the correct operation of the module's output channels. This voltage must be greater than 18 V (24 VDC supply), 36 V (48 VDC supply) for modules with direct current transistor outputs. In the event of pre-actuator voltage being less than or equal to this threshold, outputs are set to 0 and the error is show by the **I/O** LED lighting up on the front panel of the module.

NOTE: The sensor/pre-actuator voltage check is unique to terminal block modules. In 32- or 34-channel connector modules, there is one checking device per connector (equivalent to one per group of 16 channels). A sensor or pre-actuator voltage error leads to all the inputs and outputs affected by the error (i.e. all channels for a terminal block module and the group(s) of 16 channels for a 32- or 64-channel connector module) to be set to faulty.

NOTE: Relay and bidirectional triode thyristor output modules do not contain pre-actuator voltage checking devices.

Other Errors

The **Other errors** category includes switched off modules.

Description

The following table can be used to determine the module's status on the basis of the LEDs located on the Discrete I/O modules' display block.

State of module		LEDs		
		RUN (green)	ERR (red)	I/O (red)
Normal operation		●	○	○
Internal errors	Module failure, no PLC communication	○	●	○
	Module failure, PLC communication possible	●	●	○
	Communication error	●	⊗	○
External errors	Terminal block error	●	○	⊗
	Overload, short circuit, sensor/pre-actuator voltage error	●	○	●

State of module		LEDs		
		RUN (green)	ERR (red)	I/O (red)
Other errors	Module switched off	○	⊗	○
Legend:				
●		LED on		
⊗		LED flashing		
○		LED off		

WARNING

CHANNEL LED INFORMATION NOT MATCHING SENSORS POSITION

After a sensor power outage:

- The I/O error LED is on.
- Do not take into account the input LEDs information (they show the last recorded position of the sensors, not their real positions).
- Check the real positions on the sensors.

Failure to follow these instructions can result in death, serious injury, or equipment damage.

NOTE: When the sensor detects power outage, the error LED of the following modules switches on and the last recorded state of the sensor is displayed by the input LEDs.

The 24 VDC modules are:

- TSX DEY 16D2
- TSX DEY 32D2K
- TSX DEY 64D2K

The 48 VDC modules are:

- TSX DEY 16D3
- TSX DEY 32D3K

I/O LED Behavior After Power Outage

Depending of the Supply Monitoring (*see page 404*) check box in the discrete module configuration screen, the **I/O** LED behavior of the module after a power outage is different.

- When the Supply Monitoring check box is checked:
All inputs within a 16 channels group are forced to 0 by the CPU. As a result, the I/O default is transmitted and the **I/O** LED flashes.
- When the Supply Monitoring check box is unchecked:
All inputs within a 16 channels group are the last state available at the power outage occurrence. As a result, the I/O default is not transmitted and the **I/O** LED is switched off.

In both cases, the inputs state is the last state before the sensor terminal voltage disappears.

Checking the Discrete Input / Output connection

At a Glance

In order to check the Discrete I/O connection, ensure that:

- sensor data is registered by the corresponding inputs and the processor,
- control orders from the processor are registered by the outputs and transmitted to the corresponding pre-actuators.

WARNING

UNEXPECTED SYSTEM BEHAVIOR

Active outputs can activate machine movements.

Turn all power off before checking the Discrete I/O connection:

- remove power fuses from the motor controls,
- shut off the hydraulic and pneumatic units,
- then power up the PLC fitted with its Discrete I/O modules.

Failure to follow these instructions can result in death, serious injury, or equipment damage.

Description

It is possible to check the connection of the Discrete I/O modules:

- without a terminal:
 - by activating each sensor and checking whether the corresponding input LED changes status. If it remains unchanged, check the wiring and correct operation of the sensor.
- using the terminal:
 - using a terminal, it is possible to perform a more comprehensive I/O check. To do this, an application with configured I/Os at minimum (an empty application is sufficient but if the application is empty no module should be declared in the 'FAST task') should be previously loaded onto the PLC from a programming terminal,
 - this check can be carried out, with the PLC in **RUN** mode, from a PC equipped with Unity Pro software giving access to debug functions,
 - this check can also be carried out with the entire application loaded in the memory. In this case, stop the processing of the program by de-activating the MAST, FAST and event tasks (*see page 413*) by setting system bits %S30, %S31, %S38 to 0.

Input check

The following table shows the procedure for checking input connections.

Step	Action
1	Activate each sensor and check that the corresponding input LED changes status.
2	Check on the terminal screen that the corresponding input bit (%I•) also changes status.

Output check

The following table shows the procedure for checking output connections.

Step	Action
1	From the terminal, set each bit (%Q•) that corresponds to an output to 1 then 0.
2	Check that the corresponding output LED turns on then off and that the corresponding pre-actuator activates then de-activates.

TSX DEY 08D2 input module

4

Overview

This chapter describes the **TSX DEY 08D2** module, its characteristics and its connection to the different sensors.

What's in this Chapter?

This chapter contains the following topics:

Topic	Page
Presentation of the TSX DEY 08D2 module	68
Characteristics of the TSX DEY 08D2 module	69
Connecting the TSX DEY 08D2 module	71

Presentation of the TSX DEY 08D2 module

General

The **TSX DEY 08D2** module

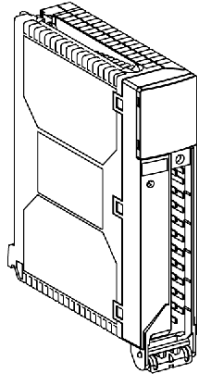

The **TSX DEY 08D2** module is a 24 VDC 8-channel terminal block Discrete input module with positive logic.

Characteristics of the TSX DEY 08D2 module

At a Glance

This section provides a description of the general characteristics of the **TSX DEY 08D2** module.

General characteristics

The following table shows the general characteristics of the **TSX DEY 08D2** module:

The TSX DEY 08D2 module		24 VDC positive logic inputs	
Nominal input values		Supply	24 VDC
		Current	7 mA
Threshold input values	at 1	Supply	≥ 11 V
		Current	≥ 6.5 mA (for $U = 11$ V)
	at 0	Supply	≤ 5 V
		Current	\leq mA
	Sensor supply (including ripple)		19..30 V (possibly up to 34 V, limited to 1 hour every 24 hours)
Input impedance	at nominal U	4 kOhms	
Response time	typical	4 ms	
	maximum	7 ms	
IEC 1131-2 compliance		type 2	
2 wire / 3 wire proximity sensor compatibility (see page 50)		IEC 947-5-2	
Dielectric strength		1500 V actual, 50 / 60 Hz for 1 min	
Insulation resistance		10 MOhms (below 500 VDC)	
Type of input		current sink	
Paralleling of inputs (1)		yes	
Sensor voltage check threshold	OK	> 18 V	
	Error	< 14 V	
Check response time	on appearance	$1 \text{ ms} < T < 3 \text{ ms}$	
	on disappearance	$8 \text{ ms} < T < 30 \text{ ms}$	
5 V consumption	typical	55 mA	
	maximum	65 mA	
Sensor supply consumption (2)	typical	$25 \text{ mA} + (7 \times N_b) \text{ mA}$	
	maximum	$33 \text{ mA} + (7 \times N_b) \text{ mA}$	

Dissipated power (2)	$1 \text{ W} + (0.15 \times \text{Nb}) \text{ W}$
Legend:	
(1)	This characteristic is used to connect several inputs to the same module in parallel, or to different modules for input redundancy.
(2)	Nb = number of channels at 1.

Connecting the TSX DEY 08D2 module

At a Glance

The **TSX DEY 08D2** module comprises 8 x 24 VDC inputs, with type 2 positive logic.

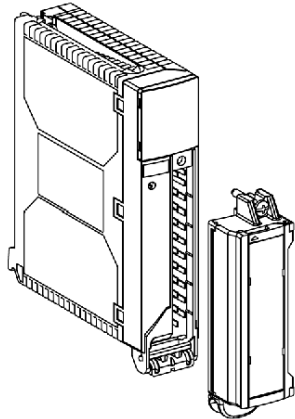

This module is fitted with a removable connection terminal block for the connection of inputs.

Principle Diagram

The circuit diagram for an input is shown below.

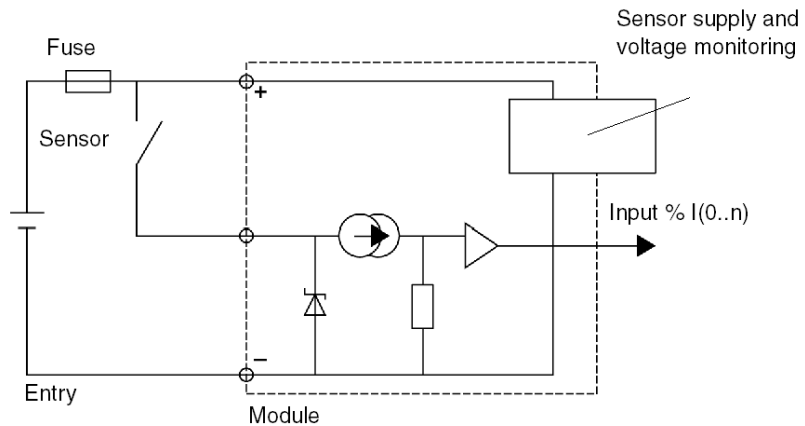

Module connection

The following diagram shows the connection of the module to the sensors.

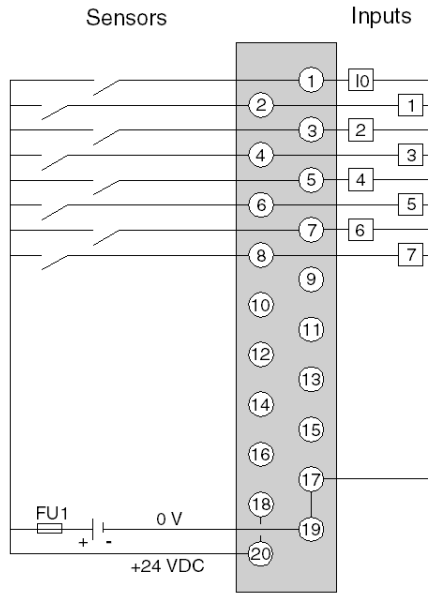

FU1 0.5 A quick-blow fuse

TSX DEY 16D2 Discrete input module

5

Overview

This chapter describes the **TSX DEY 16D2** module, its characteristics and its connection to the different sensors.

What's in this Chapter?

This chapter contains the following topics:

Topic	Page
Presentation of the TSX DEY 16D2 module	74
Characteristics of the TSX DEY 16D2 module	75
Temperature downgrading for the Discrete I/O modules	77
Connecting the TSX DEY 16D2 module	79

Presentation of the TSX DEY 16D2 module

General

The **TSX DEY 16D2** module

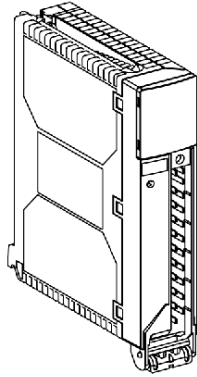

The **TSX DEY 16D2** module is a 24 VDC 16-channel terminal block Discrete input module with positive logic.

Characteristics of the TSX DEY 16D2 module

At a Glance

This section provides a description of the general characteristics of the **TSX DEY 16D2** module.

General characteristics

The following table shows the general characteristics of the **TSX DEY 16D2** module:

The TSX DEY 16D2 module		24 VDC positive logic inputs	
Nominal input values		Supply	24 VDC
		Current	7 mA
Threshold input values	at 1	Supply	≥ 11 V
		Current	≥ 6.5 mA (for $U = 11$ V)
	at 0	Supply	≤ 5 V
		Current	≤ 2 mA
	Sensor supply (including ripple)		19..30 V (possibly up to 34 V, limited to 1 hour every 24 hours)
Input impedance	at nominal U	4 kOhms	
Response time	minimum	4 ms	
	maximum	7 ms	
IEC 1131-2 compliance		type 2	
2 wire / 3 wire proximity sensor compatibility (see page 50)		IEC 947-5-2	
Dielectric strength		1500 V actual, 50 / 60 Hz for 1 min	
Insulation resistance		10 MOhms (below 500 VDC)	
Type of input		current sink	
Paralleling of inputs (1)		yes	
Sensor voltage check threshold	OK	> 18 V	
	Error	< 14 V	
Check response time	on appearance	$1 \text{ ms} < T < 3 \text{ ms}$	
	on disappearance	$8 \text{ ms} < T < 30 \text{ ms}$	
5 V consumption	typical	80 mA	
	maximum	90 mA	
Sensor supply consumption (2)	typical	$25 \text{ mA} + (7 \times \text{Nb}) \text{ mA}$	
	maximum	$33 \text{ mA} + (7 \times \text{Nb}) \text{ mA}$	
Dissipated power (2)		$1 \text{ W} + (0.15 \times \text{Nb}) \text{ W}$	

Temperature downgrading (<i>see page 77</i>)	The characteristics at 60 °C are guaranteed for 60 % of inputs set to 1
Legend:	
(1)	This characteristic is used to connect several inputs to the same module in parallel, or to different modules for input redundancy.
(2)	Nb = number of channels at 1.

Temperature downgrading for the Discrete I/O modules

At a Glance

All characteristics for the different Discrete modules are given for a load rate of 60 % of channels simultaneously set to 1.

In the event of a greater load rate, refer to the following downgrading curve.

Temperature downgrading of the Discrete I/O modules.

Percentage of channels at 1

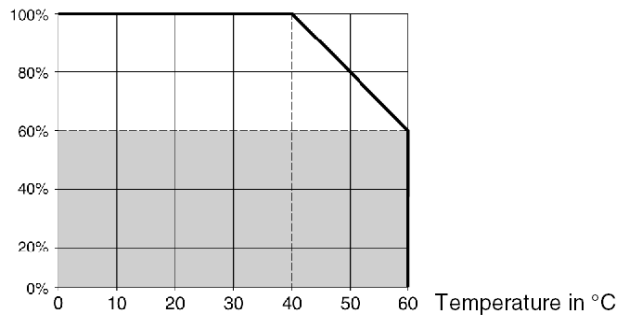

Relay outputs

There is no temperature downgrading for relay output modules (**TSX DSY 08R5/08R4D/08R5A/16R5**). The user must therefore check there is enough overall consumption on the 24 V supply.

NOTE: for the outputs, temperature downgrading is based on the maximum current flowing from the active outputs.

The TSX DEY 32D3K module

When the **TSX DEY 32D3K** module is used under extreme conditions (sensor voltage and temperature), the downgrading conditions defined below must be respected.

Temperature downgrading for the Discrete I/O module **TSX DEY 32D3K**.

Percentage of channels at 1

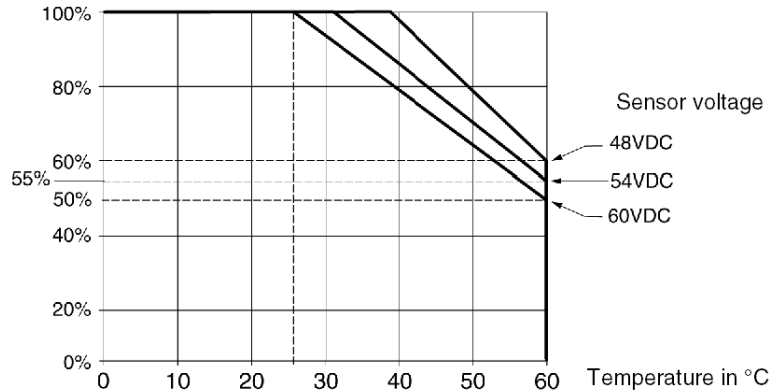

The following curves show the percentage of inputs simultaneously set to 1, depending on:

- service temperature,
- sensor supply voltage.

Connecting the TSX DEY 16D2 module

At a Glance

The **TSX DEY 16D2** module comprises 16 x 24 VDC inputs, with type 2 positive logic.

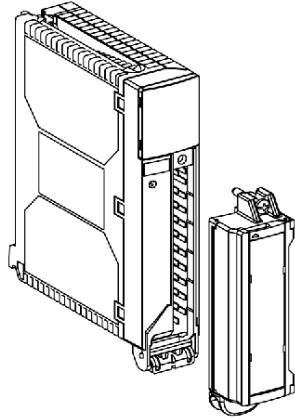

This module is fitted with a removable connection terminal block for the connection of inputs.

Principle Diagram

The circuit diagram for an input is shown below.

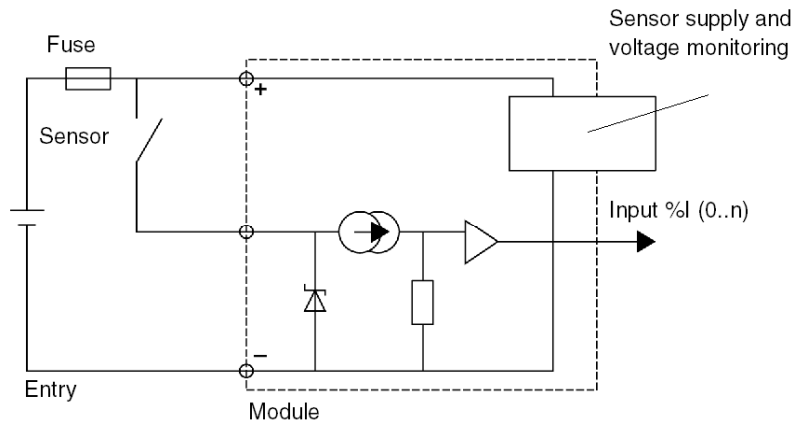

Module connection

The following diagram shows the connection of the module to the sensors.

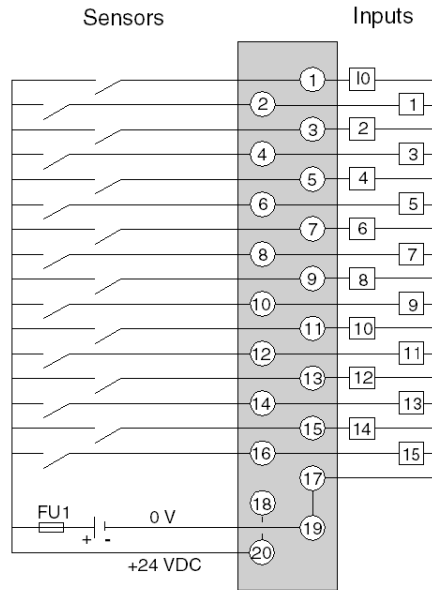

FU1 0.5 A quick-blow fuse

TSX DEY 16D3 Discrete input module

6

Overview

This chapter describes the **TSX DEY 16D3** module, its characteristics and its connection to the different sensors.

What's in this Chapter?

This chapter contains the following topics:

Topic	Page
Presentation of the TSX DEY 16D3 module	82
Characteristics of the TSX DEY 16D3 module	83
Connecting the TSX DEY 16D3 module	85

Presentation of the TSX DEY 16D3 module

General

The **TSX DEY 16D3** module

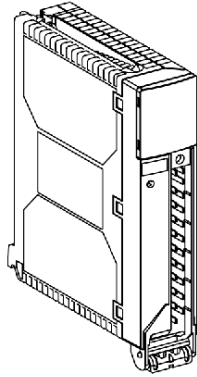

The **TSX DEY 16D3** module is a 48 VDC 16-channel terminal block Discrete input module with positive logic.

Characteristics of the TSX DEY 16D3 module

At a Glance

This section provides a description of the general characteristics of the **TSX DEY 16D3** module.

General characteristics

The following table shows the general characteristics of the **TSX DEY 16D3** module:

The TSX DEY 16D3 module		48 VDC positive logic inputs	
Nominal input values		Supply	48 VDC
		Current	7 mA
Threshold input values	at 1	Voltage	≥ 30 V
		Current	≥ 6.5 mA (for $U = 30$ V)
	at 0	Voltage	≤ 10 V
		Current	≤ 2 mA
	Sensor supply (including ripple)		38..60 V
Input impedance	at nominal U	7 kOhms	
Response time	typical	4 ms	
	maximum	7 ms	
IEC 1131-2 compliance		type 2	
2 wire / 3 wire proximity sensor compatibility (see page 50)		IEC 947-5-2	
Dielectric strength		1500 V actual, 50 / 60 Hz for 1 min	
Insulation resistance		10 MOhms (below 500 VDC)	
Type of input		current sink	
Paralleling of inputs (1)		yes	
Sensor voltage check threshold	OK	> 36 V	
	Error	< 24 V	
Check response time	on appearance	$1 \text{ ms} < T < 3 \text{ ms}$	
	on disappearance	$8 \text{ ms} < T < 30 \text{ ms}$	
5 V consumption	typical	80 mA	
	maximum	90 mA	
Sensor supply consumption (2)	typical	$25 \text{ mA} + (7 \times N_b) \text{ mA}$	
	maximum	$33 \text{ mA} + (7 \times N_b) \text{ mA}$	
Dissipated power (2)		$1 \text{ W} + (0.3 \times N_b) \text{ W}$	

Temperature downgrading (<i>see page 77</i>)	The characteristics at 60 °C are guaranteed for 60 % of inputs set to 1
Legend:	
(1)	This characteristic is used to connect several inputs to the same module in parallel, or to different modules for input redundancy.
(2)	Nb = number of channels at 1.

Connecting the TSX DEY 16D3 module

At a Glance

The **TSX DEY 16D3** module comprises 16 x 48 VDC inputs, with type 2 positive logic.

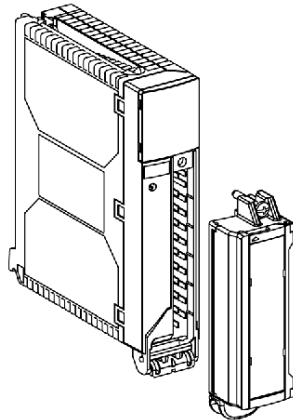

This module is fitted with a removable connection terminal block for the connection of inputs.

Principle Diagram

The circuit diagram for an input is shown below.

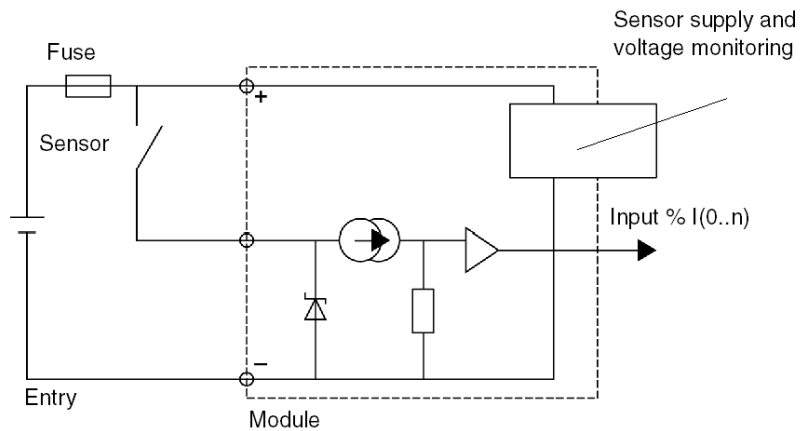

Module connection

The following diagram shows the connection of the module to the sensors.

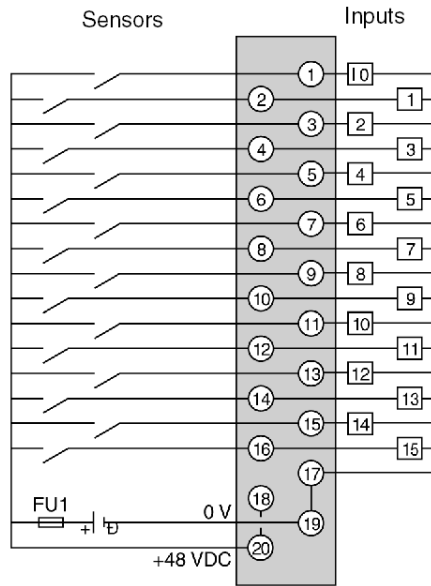

FU1 0.5 A quick-blow fuse

TSX DEY 16A2 Discrete input module

7

Overview

This chapter describes the **TSX DEY 16A2** module, its characteristics and its connection to the different sensors.

What's in this Chapter?

This chapter contains the following topics:

Topic	Page
Presentation of the TSX DEY 16A2 module	88
Characteristics of the alternating voltage TSX DEY 16A2 module	89
Characteristics of the 24 VDC negative logic TSX DEY 16A2 module	91
Connecting the alternating voltage TSX DEY 16A2 module	93
Connecting the 24 VDC negative logic TSX DEY 16A2 module	95

Presentation of the TSX DEY 16A2 module

General

The **TSX DEY 16A2** module

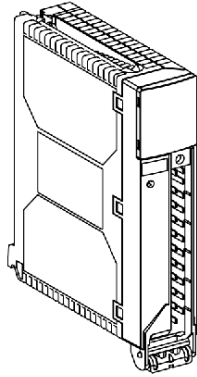

The **TSX DEY 16A2** module is a 24 VAC 16-channel terminal block Discrete input module.

Although intended for AC use, this module can also be used with direct current for negative logic applications.

Characteristics of the alternating voltage TSX DEY 16A2 module

At a Glance

This section provides a description of the characteristics of the alternating voltage **TSX DEY 16A2** module.

Characteristics

The following table shows the characteristics of the alternating voltage **TSX DEY 16A2** module:

The TSX DEY 16A2 module		24 VAC alternating voltage inputs	
Nominal input values	Voltage	24 VAC	
	Current	15 mA	
	Frequency	50 / 60 Hz	
Threshold input values	at 1	Voltage	≥ 10 V
		Current	≥ 6 mA (for U = 10 V)
	at 0	Voltage	≤ 5 V
		Current	≤ 4 mA
	Frequency	47..63 HZ	
	Sensor supply	20..26 V	
	Peak current at activation (at nominal U)	15 mA	
Input impedance	at nominal U	1.6 kOhms	
Response time	Activation	15 ms	
	Deactivation	20 ms	
IEC 1131-2 compliance		type 2	
2 wire / 3 wire proximity sensor compatibility (see page 50)		IEC 947-5-2	
Dielectric strength	Input / ground or Input / internal logic	1500 V actual, 50 / 60 Hz for 1 min	
Insulation resistance		> 10 MOhms (below 500 VDC)	
Type of input		Resistive	
Sensor voltage check threshold	OK	> 18 V	
	Error	< 14 V	
Check response time	on appearance	20 ms < T < 50 ms	
	on disappearance	5 ms < T < 15 ms	
5 V consumption	typical	80 mA	
	maximum	90 mA	

Sensor supply consumption (1)	typical	15 mA + (15 x Nb) mA
	maximum	19 mA + (15 x Nb) mA
Dissipated power (1)		1 W + (0.35 x Nb) W
Temperature downgrading (see page 77)		The characteristics at 60 °C are guaranteed for 60 % of inputs set to 1
Legend:		
(1)	Nb = number of channels at 1.	

Characteristics of the 24 VDC negative logic TSX DEY 16A2 module

At a Glance

This section provides a description of the characteristics of the 24 VDC direct current negative logic **TSX DEY 16A2** module.

Characteristics

The following table shows the characteristics of the 24 VDC negative logic **TSX DEY 16A2** module:

The TSX DEY 16A2 module		24 VDC negative logic inputs	
Nominal input values	Voltage	24 VDC	
	Current	16 mA (output)	
Threshold input values (1)	at 1	Voltage	$\geq (U_{al} - 14 \text{ V})$
		Current	$\geq 6.5 \text{ mA (output)}$
	at 0	Voltage	$\leq (U_{al} - 5 \text{ V})$
		Current	$\leq 2 \text{ mA (output)}$
Sensor supply (including ripple)		19..30 V (possibly up to 34 V, limited to 1 hour every 24 hours)	
Input impedance	at nominal U	1.6 kOhms	
Response time	typical	10 ms	
	maximum	20 ms	
IEC 1131-2 compliance		negative logic not taken into account by the standard	
2 wire / 3 wire proximity sensor compatibility (see page 50)		IEC 947-5-2	
Dielectric strength	Input / ground or Input / internal logic	1500 V actual, 50 / 60 Hz for 1 min	
Insulation resistance		> 10 MOhms (below 500 VDC)	
Type of input		Resistive	
Paralleling of inputs		No	
Sensor voltage check threshold	OK	> 18 V	
	Error	< 14 V	
Check response time	on appearance	20 ms < T < 40 ms	
	on disappearance	5 ms < T < 10 ms	
5 V consumption	typical	80 mA	
	maximum	90 mA	
Sensor supply consumption (2)	typical	15 mA + (15 x Nb) mA	
	maximum	19 mA + (15 x Nb) mA	

Dissipated power (2)	$1\text{ W} + (0.4 \times \text{Nb})\text{ W}$
Temperature downgrading (see page 77)	The characteristics at 60 °C are guaranteed for 60 % of inputs set to 1
Legend:	
(1)	Ua1 = Sensor supply
(2)	Nb = number of channels at 1.

NOTE: the **TSX DEY 16A2** module input filtering time is between 10 and 20 ms.

Connecting the alternating voltage TSX DEY 16A2 module

At a Glance

The alternating voltage **TSX DEY 16A2** module comprises 16 x 24 VAC type 2 inputs.

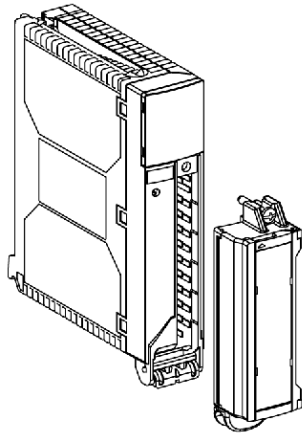

This module is fitted with a removable connection terminal block for the connection of inputs.

Circuit diagram

The circuit diagram for an input is shown below.

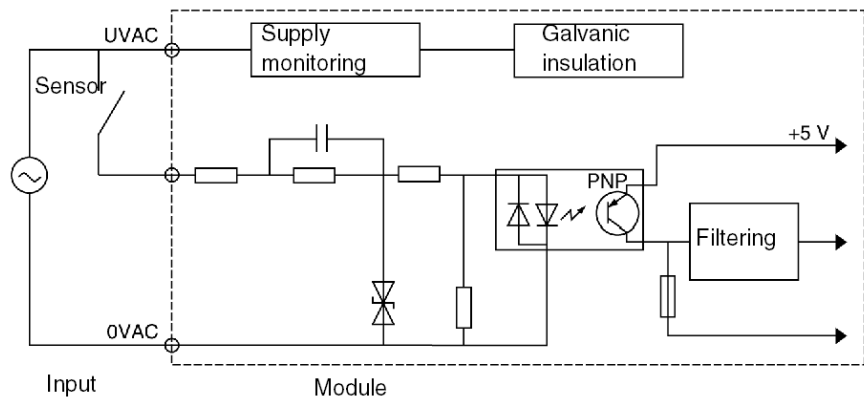

Module connection

The following diagram shows the connection of the module to the sensors.

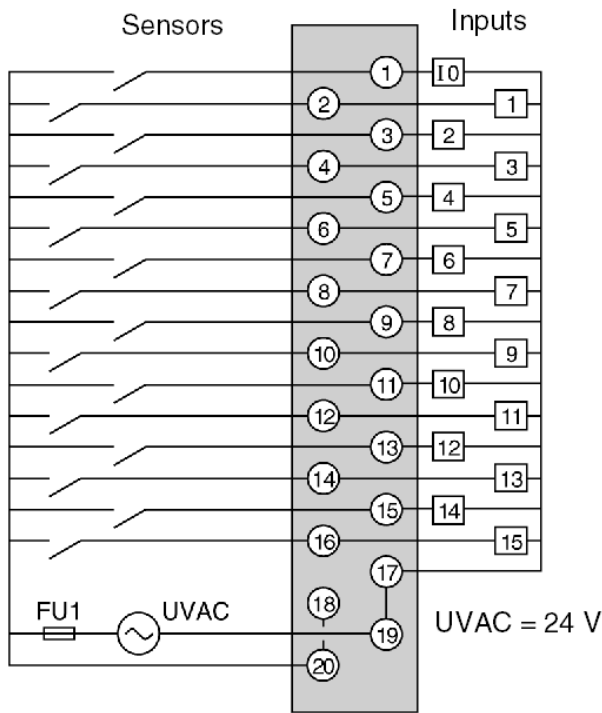

FU1 0.5 A quick-blow fuse

Connecting the 24 VDC negative logic TSX DEY 16A2 module

At a Glance

The **TSX DEY 16A2** module can be use in direct current with its 16 inputs in negative logic.

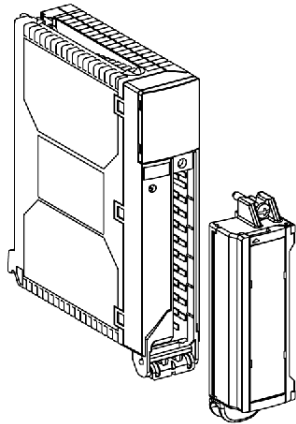

This module is fitted with a removable connection terminal block for the connection of inputs.

Module connection

The following diagram shows the connection of the module to the sensors.

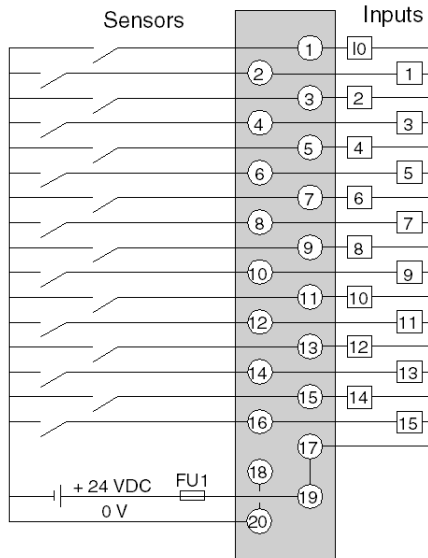

FU1 0.5 A quick-blow fuse

NOTE: When the 0 V sensor is grounded, it is not recommended to use the negative logic. If a wire should accidentally become disconnected and come into contact with the mechanical ground, this might set the input to 1, which could create an accidental command.

TSX DEY 16A3 Discrete input module



Overview

This chapter describes the **TSX DEY 16A3** module, its characteristics and its connection to the different sensors.

What's in this Chapter?

This chapter contains the following topics:

Topic	Page
Presentation of the TSX DEY 16A3 module	98
Characteristics of the TSX DEY 16A3 module	99
Connecting the TSX DEY 16A3 module	101

Presentation of the TSX DEY 16A3 module

General

The **TSX DEY 16A3** module

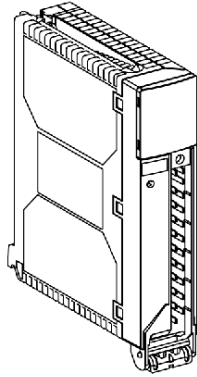

The **TSX DEY 16A3** module is a 48 VAC 16-channel terminal block Discrete input module.

Characteristics of the TSX DEY 16A3 module

At a Glance

This section provides a description of the general characteristics of the **TSX DEY 16A3** module.

General characteristics

The following table shows the general characteristics of the **TSX DEY 16A3** module:

The TSX DEY 16A3 module		48 VAC alternating voltage inputs	
Nominal input values		Voltage	48 VAC
		Current	16 mA
		Frequency	50 / 60 Hz
Threshold input values	at 1	Voltage	≥ 29 V
		Current	≥ 6 mA (for U = 29 V)
	at 0	Voltage	≤ 10 V
		Current	≤ 4 mA
	Frequency	47..63 HZ	
	Sensor supply	40..52 V	
	Peak current at activation (at nominal U)	80 mA	
Input impedance	at nominal U	3.2 kOhms	
Response time	Activation	10 ms	
	Deactivation	20 ms	
IEC 1131-2 compliance		type 2	
2 wire / 3 wire proximity sensor compatibility (see page 50)		IEC 947-5-2	
Dielectric strength	Input / ground or Input / internal logic	1500 V actual, 50 / 60 Hz for 1 min	
Insulation resistance		> 10 MOhms (below 500 VDC)	
Type of input		Capacitive	
Sensor voltage check threshold	OK	> 36 V	
	Error	< 24 V	
Check response time	on appearance	20 ms < T < 50 ms	
	on disappearance	5 ms < T < 15 ms	
5 V consumption	typical	80 mA	
	maximum	90 mA	

Sensor supply consumption (1)	typical	$16 \text{ mA} + (16 \times \text{Nb}) \text{ mA}$
	maximum	$20 \text{ mA} + (16 \times \text{Nb}) \text{ mA}$
Dissipated power (1)		$1 \text{ W} + (0.35 \times \text{Nb}) \text{ W}$
Temperature downgrading (see page 77)		The characteristics at 60 °C are guaranteed for 60 % of inputs set to 1
Legend:		
(1)	Nb = number of channels at 1.	

Connecting the TSX DEY 16A3 module

At a Glance

The **TSX DEY 16A3** module comprises 16 x 48 VAC type 2 inputs.

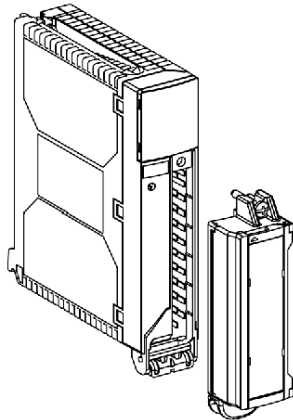

This module is fitted with a removable connection terminal block for the connection of inputs.

Circuit diagram

The circuit diagram for an input is shown below.

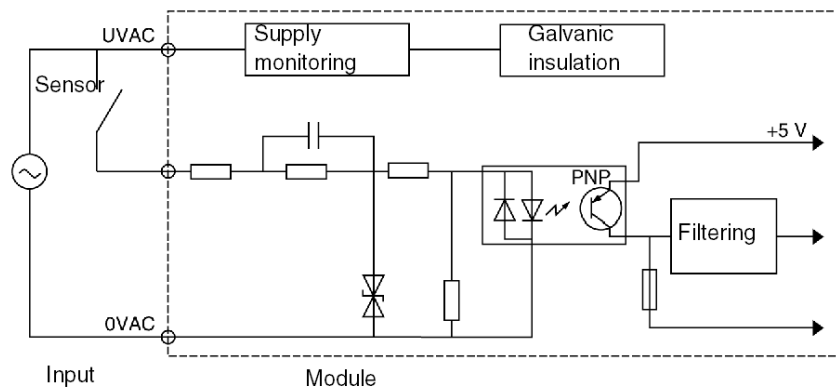

Module connection

The following diagram shows the connection of the module to the sensors.

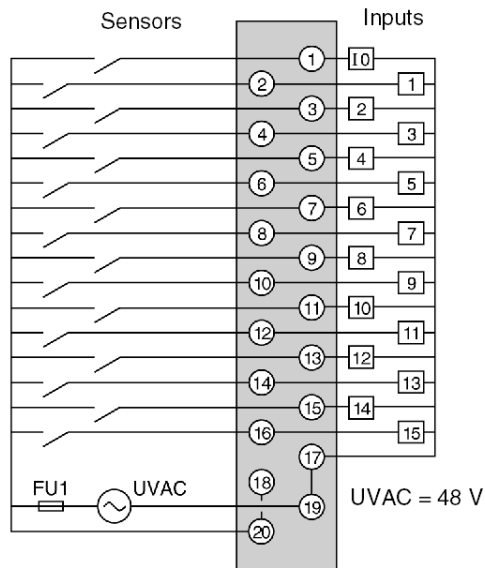

FU1 0.5 A quick-blow fuse

TSX DEY 16A4 Discrete input module

9

Overview

This chapter describes the **TSX DEY 16A4** module, its characteristics and its connection to the different sensors.

What's in this Chapter?

This chapter contains the following topics:

Topic	Page
Presentation of the TSX DEY 16A4 module	104
Characteristics of the TSX DEY 16A4 module	105
Connecting the TSX DEY 16A4 module	107

Presentation of the TSX DEY 16A4 module

General

The **TSX DEY 16A4** module

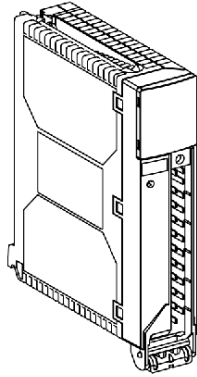

The **TSX DEY 16A4** module is a 100...120 VAC 16-channel terminal block Discrete input module.

Characteristics of the TSX DEY 16A4 module

At a Glance

This section provides a description of the general characteristics of the **TSX DEY 16A4** module.

General characteristics

The following table shows the general characteristics of the **TSX DEY 16A4** module:

The TSX DEY 16A4 module		100..120 VAC alternating voltage inputs	
Nominal input values	Voltage	100..120 VAC	
	Current	12 mA	
	Frequency	50 / 60 Hz	
Threshold input values	at 1	Voltage	≥ 74 V
		Current	≥ 6 mA (for U = 74 V)
	at 0	Voltage	≤ 20 V
		Current	≤ 4 mA
	Frequency	47..63 HZ	
	Sensor supply	85..132 V	
	Peak current at activation (at nominal U)	160 mA	
Input impedance	at nominal U	9.2 kOhms	
Response time	Activation	10 ms	
	Deactivation	20 ms	
IEC 1131-2 compliance		type 2	
2 wire / 3 wire proximity sensor compatibility (see page 50)		IEC 947-5-2	
Dielectric strength	Input / ground or Input / internal logic	1500 V actual, 50 / 60 Hz for 1 min	
Insulation resistance		> 10 MOhms (below 500 VDC)	
Type of input		Capacitive	
Sensor voltage check threshold	OK	> 82 V	
	Error	< 40 V	
Check response time	on appearance	20 ms < T < 50 ms	
	on disappearance	5 ms < T < 15 ms	
5 V consumption	typical	80 mA	
	maximum	90 mA	

Sensor supply consumption (1)	typical	15 mA + (15 x Nb) mA
	maximum	19 mA + (15 x Nb) mA
Dissipated power (1)		1 W + (0.35 x Nb) W
Temperature downgrading (see page 77)		The characteristics at 60 °C are guaranteed for 60 % of inputs set to 1
Legend:		
(1)	Nb = number of channels at 1.	

Connecting the TSX DEY 16A4 module

At a Glance

The **TSX DEY 16A4** module comprises 16 x 120 VAC type 2 inputs.

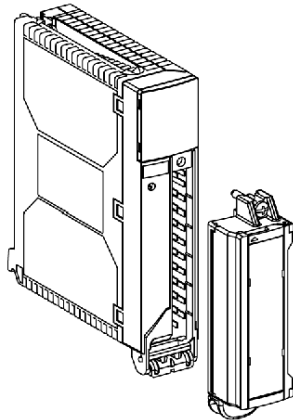

This module is fitted with a removable connection terminal block for the connection of inputs.

Circuit diagram

The circuit diagram for an input is shown below.

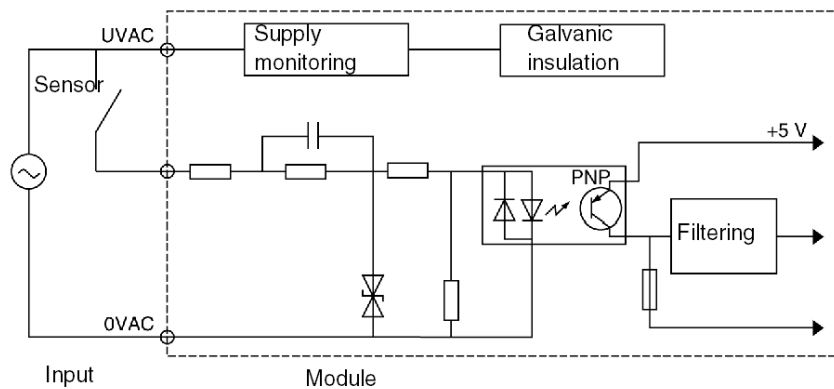

Module connection

The following diagram shows the connection of the module to the sensors.

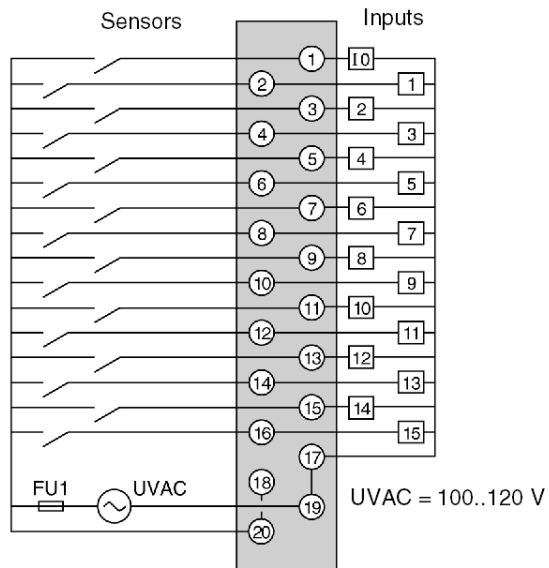

FU1 0.5 A quick-blow fuse

TSX DEY 16A5 Discrete input module

10

Overview

This chapter describes the **TSX DEY 16A5** module, its characteristics and its connection to the different sensors.

What's in this Chapter?

This chapter contains the following topics:

Topic	Page
Presentation of the TSX DEY 16A5 module	110
Characteristics of the TSX DEY 16A5 module	111
Connecting the TSX DEY 16A5 module	113

Presentation of the TSX DEY 16A5 module

General

The **TSX DEY 16A5** module

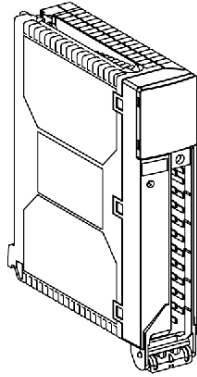

The **TSX DEY 16A5** module is a 200..240 VAC 16-channel terminal block Discrete input module.

Characteristics of the TSX DEY 16A5 module

At a Glance

This section provides a description of the general characteristics of the **TSX DEY 16A5** module.

General characteristics

The following table shows the general characteristics of the **TSX DEY 16A5** module:

The TSX DEY 16A5 module		200..240 VAC alternating voltage inputs	
Nominal input values	Voltage	200..240 VAC	
	Current	15 mA	
	Frequency	50 / 60 Hz	
Threshold input values	at 1	Voltage	≥ 159 V
		Current	≥ 6 mA (for U = 159 V)
	at 0	Voltage	≤ 40 V
		Current	≤ 4 mA
	Frequency	47..63 HZ	
	Sensor supply	170..264 V	
	Peak current at activation (at nominal U)	300 mA	
Input impedance	at nominal U	20 kOhms	
Response time	Activation	10 ms	
	Deactivation	20 ms	
IEC 1131-2 compliance		type 1	
2 wire / 3 wire proximity sensor compatibility (see page 50)		IEC 947-5-2	
Dielectric strength	Input / ground or Input / internal logic	2000 V actual, 50 / 60 Hz for 1 min	
Insulation resistance		> 10 MOhms (below 500 VDC)	
Type of input		Capacitive	
Sensor voltage check threshold	OK	> 164 V	
	Error	< 80 V	
Check response time	on appearance	20 ms < T < 50 ms	
	on disappearance	5 ms < T < 15 ms	
5 V consumption	typical	80 mA	
	maximum	90 mA	

Sensor supply consumption (1)	typical	$12 \text{ mA} + (12 \times \text{Nb}) \text{ mA}$
	maximum	$16 \text{ mA} + (12 \times \text{Nb}) \text{ mA}$
Dissipated power (1)		$1 \text{ W} + (0.4 \times \text{Nb}) \text{ W}$
Temperature downgrading (see page 77)		The characteristics at 60°C are guaranteed for 60 % of inputs set to 1
Legend:		
(1)	Nb = number of channels at 1.	

Connecting the TSX DEY 16A5 module

At a Glance

The **TSX DEY 16A5** module comprises 16 x 200..240 VAC type 1 inputs.

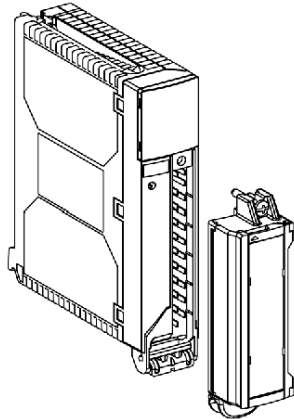

This module is fitted with a removable connection terminal block for the connection of inputs.

Circuit diagram

The circuit diagram for an input is shown below.

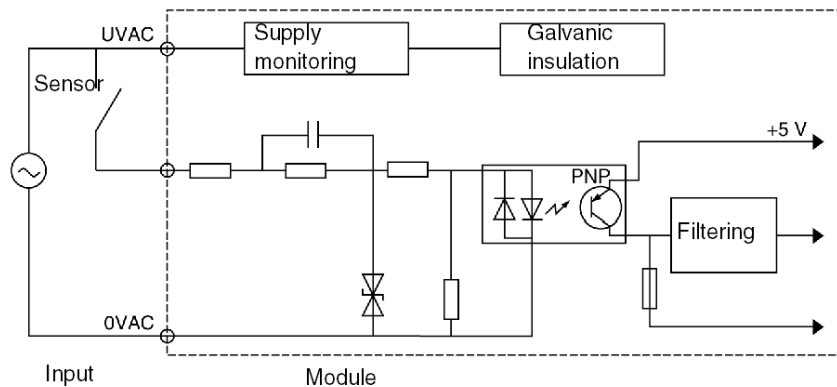

Module connection

The following diagram shows the connection of the module to the sensors.

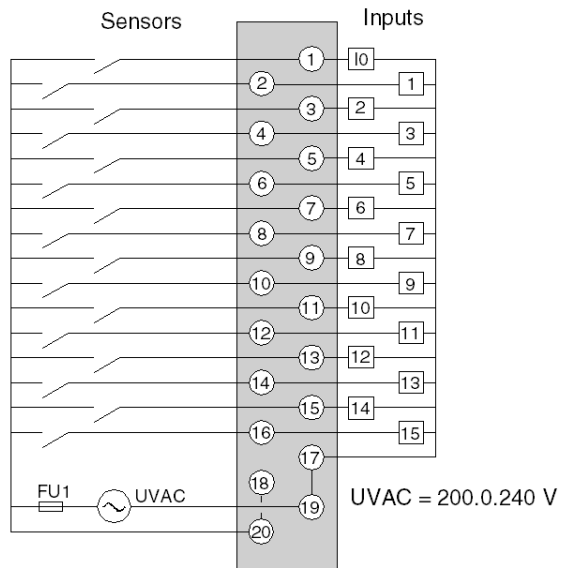

FU1 0.5 A quick-blow fuse

The TSX DEY 16FK Discrete input module

11

Overview

This chapter describes the **TSX DEY 16FK** module, its characteristics and its connection to the different sensors.

What's in this Chapter?

This chapter contains the following topics:

Topic	Page
Presentation of the TSX DEY 16FK module	116
Specific functions of Discrete modules: programmable input filtering	117
Specific Functions of Discrete Modules: Input Latching	118
Specific Functions of Discrete Modules: Input Event Management	120
Characteristics of the TSX DEY 16FK module	121
Connecting the TSX DEY 16FK module	123

Presentation of the TSX DEY 16FK module

General

The **TSX DEY 16FK** module

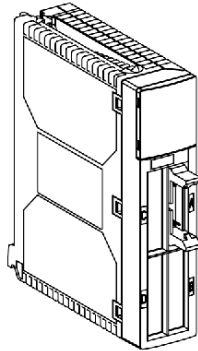

The **TSX DEY 16FK** module is a 24 VDC 16 fast connector channel Discrete input module with positive logic.

This module's inputs have the following specific functions:

- programmable filtering: inputs are equipped with a filtering system which is configurable for each channel,
- latching: allows particularly short pulses with a duration lower than the PLC cycle time to be taken into account,
- event inputs: allows events to be taken into account and processed immediately.

Specific functions of Discrete modules: programmable input filtering

At a Glance

The **TSX DEY 16FK**, **TSX DMY 28FK** and **TSX DMY 28RFK** modules are equipped with a filtering system which is configurable per channel and allows the input filtering time to be modified.

Description

The inputs of modules **TSX DEY 16FK**, **TSX DMY 28FK** and **TSX DMY 28RFK** are filtered by:

- a fixed analog filter ensuring a maximum immunity of 0.1 ms for line interference filtering;
- a digital filter which can be configured in steps of 0.5 ms. The terminal can be used to adjust this filtering in configuration mode (*see page 417*).

NOTE: for bounces not to be taken into account upon closure of the mechanical contacts, it is recommended to use a filtering time > 3 ms.

NOTE: in order to be IEC 1131-2 compliant, the filtering time must be set to a value ≥ 3.5 ms.

Specific Functions of Discrete Modules: Input Latching



At a Glance

Modules **TSX DEY 16FK** and **TSX DMY 28FK** are equipped with the input latching function.

The input latching function allows particularly short pulses with a duration lower than the PLC cycle time to be taken into account.

This function takes the pulse into account, in order to process it in the following master (**MAST**) or fast (**FAST**) task cycle without interrupting the PLC cycle.

The pulse is taken into account when the input's status is changed, which can be either:

- a switch from 0 to 1  ;
- a switch from 1 to 0  .

Illustration

The following diagram shows the process of latching a state on a pulse from 0 to 1.

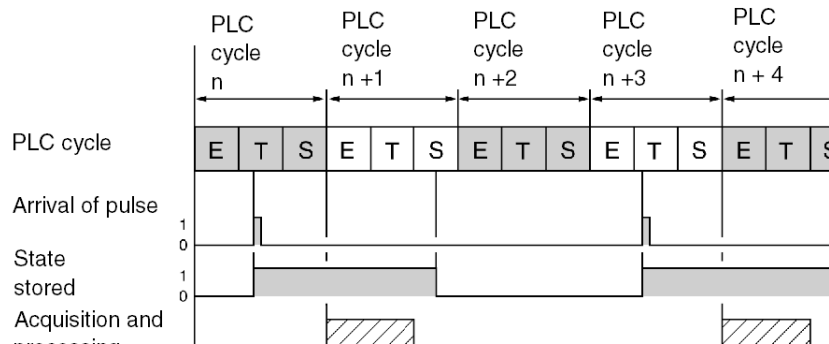

Illustration

The following diagram shows the process of latching a state on a pulse from 1 to 0.

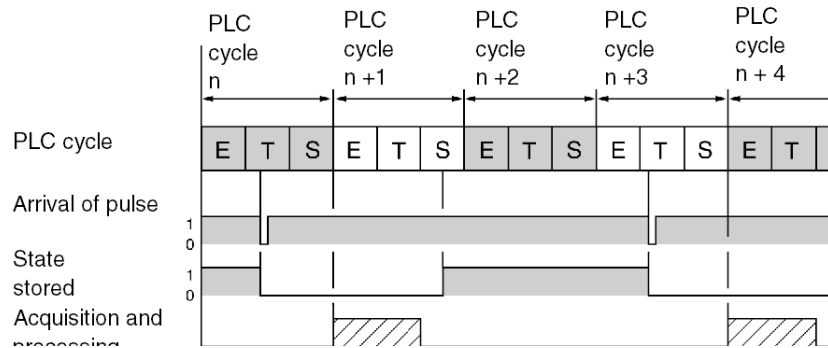

Description

The following table gives a description of the elements shown in the above diagrams:

Reference Number	Description
I	Input acquisition.
A	Processing of program.
S	Outputs updated.

NOTE: the time separating the arrival of two pulses at the same input must be greater than or equal to two PLC cycle times.

NOTE: the minimum duration of a pulse must be greater than the chosen filtering time.

Specific Functions of Discrete Modules: Input Event Management

At a Glance

Modules **TSX DEY 16FK** and **TSX DMY 28FK** can be used to configure up to 16 event inputs (*see page 413*). These inputs allow events (**Evt**) to be taken into account, and ensure that they are immediately processed by the processor (uninterrupted processing).

Description

Event processing priority is given to the number 0. The event 0 is solely associated to channel 0.

Event processing can be triggered:

- on a rising edge (from 0 to 1);
- on a falling edge (from 1 to 0) of the associated input;

When two edges are detected simultaneously on a module, the events are processed according to channel number, in ascending order.

The edge recurrence time on each input, or the pulse width on an input programmed in FM + FD, must correspond to those shown in the following diagram:

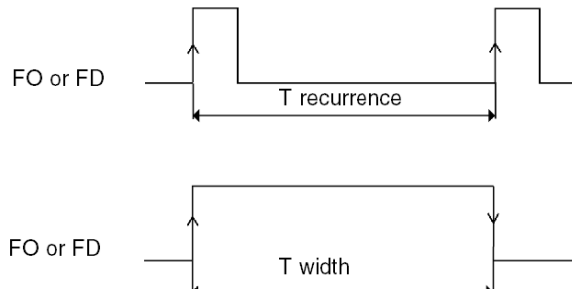

Given that

$T_{\text{recurrence}} \text{ or } T_{\text{width}} > 0.25 \text{ ms} + (0.25 \times \text{number of module Evt})$;

Max. Evt frequency = 1 kHz / number of module Evt;

Max. number of Evt in burst = 100 Evt per 100 ms.

Characteristics of the TSX DEY 16FK module

At a Glance

This section provides a description of the general characteristics of the **TSX DEY 16FK** module.

General characteristics

The following table shows the general characteristics of the **TSX DEY 16FK** module:

The TSX DEY 16FK module		24 VDC positive logic fast inputs	
Nominal input values		Voltage	24 VDC
		Current	3.5 mA
Threshold input values	at 1	Voltage	≥ 11 V
		Current	≥ 3 mA
	at 0	Voltage	≤ 5 V
		Current	≤ 1.5 mA
Sensor supply (including ripple)		19..30 V (possibly up to 34 V, limited to 1 hour every 24 hours)	
Input impedance	at nominal U	6.3 kOhms	
Response time	by default	4 ms	
	configurable filtering	0.1..7.5 ms (in 0.5 ms steps)	
IEC 1131-2 compliance		type 1	
2 wire / 3 wire proximity sensor compatibility (see page 50)		IEC 947-5-2	
Dielectric strength	Input / ground or Input / internal logic	1500 V actual, 50 / 60 Hz for 1 min	
Insulation resistance		> 10 MOhms (below 500 VDC)	
Type of input		current sink	
Paralleling of inputs (1)		Yes	
Sensor voltage check threshold	OK	> 18 V	
	Error	< 14 V	
Check response time	on appearance	8 ms < T < 30 ms	
	on disappearance	1 ms < T < 3 ms	
5 V consumption	typical	250 mA	
	maximum	300 mA	
Sensor supply consumption (2)	typical	20 mA + (3.5 x Nb) mA	
	maximum	30 mA + (3.5 x Nb) mA	

Dissipated power (2)	1.2 W + (0.1 x Nb) W
Temperature downgrading (see page 77)	The characteristics at 60 °C are guaranteed for 60 % of inputs set to 1
Legend:	
(1)	This characteristic is used to connect several inputs to the same module in parallel, or to different modules for input redundancy.
(2)	Nb = number of channels at 1.

Connecting the TSX DEY 16FK module

At a Glance

The **TSX DEY 16FK** module comprises 16 x 24 VDC type 1 fast input channels.

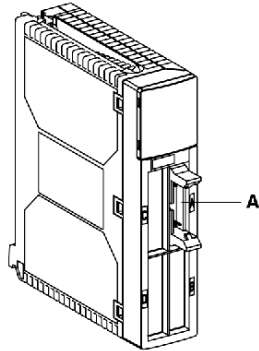

This module is equipped with a male **HE10** connector (A) linked to the connection of inputs 0 to 15.

Principle Diagram

The circuit diagram for an input is shown below.

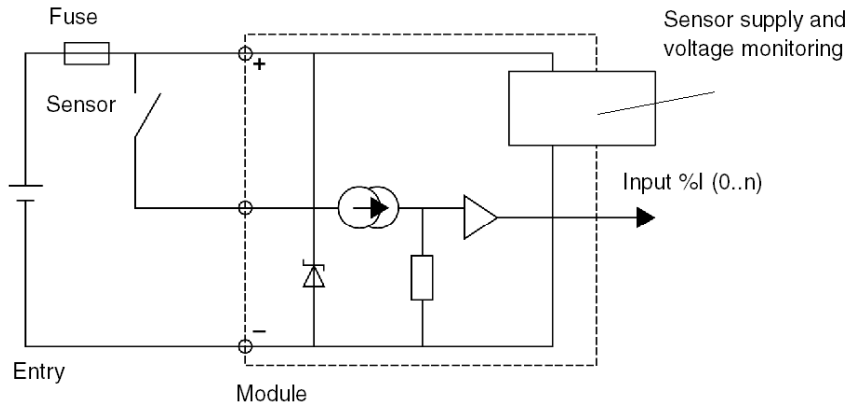

Module connection

The following diagram shows the connection of the module to the sensors.

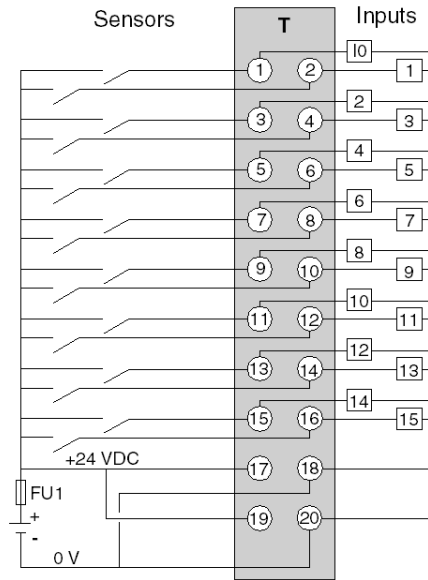

FU1 0.5 A quick-blow fuse

The TSX DEY 32D2K Discrete input module

12

Overview

This chapter describes the **TSX DEY 32D2K** module, its characteristics and its connection to the different sensors.

What's in this Chapter?

This chapter contains the following topics:

Topic	Page
Presentation of the TSX DEY 32D2K module	126
Characteristics of the TSX DEY 32D2K module	127
Connecting the TSX DEY 32D2K module	129

Presentation of the TSX DEY 32D2K module

General

The **TSX DEY 32D2K** module

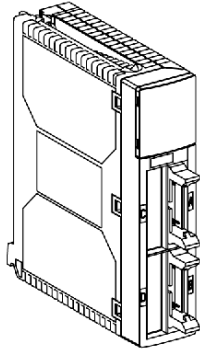

The **TSX DEY 32D2K** module is a 24 VDC 32-channel connector Discrete input module with positive logic.

Characteristics of the TSX DEY 32D2K module

At a Glance

This section provides a description of the general characteristics of the **TSX DEY 32D2K** module.

General characteristics

The following table shows the general characteristics of the **TSX DEY 32D2K** module:

The TSX DEY 32D2K module		24 VDC positive logic inputs	
Nominal input values		Voltage	24 VDC
		Current	3.5 mA
Threshold input values	at 1	Voltage	≥ 11 V
		Current	≥ 3 mA
	at 0	Voltage	≤ 5 V
		Current	≤ 1.5 mA
Sensor supply (including ripple)		19..30 V (possibly up to 34 V, limited to 1 hour every 24 hours)	
Input impedance	at nominal U	6.3 kOhms	
Response time		4 ms	
IEC 1131-2 compliance		type 1	
2 wire / 3 wire proximity sensor compatibility (see page 50)		IEC 947-5-2	
Dielectric strength	Input / ground or Input / internal logic	1500 V actual, 50 / 60 Hz for 1 min	
Insulation resistance		> 10 MOhms (below 500 VDC)	
Type of input		current sink	
Paralleling of inputs		No	
Sensor voltage check threshold	OK	> 18 V	
	Error	< 14 V	
Check response time	on appearance	8 ms < T < 30 ms	
	on disappearance	1 ms < T < 3 ms	
5 V consumption	typical	135 mA	
	maximum	155 mA	
Sensor supply consumption (1)	typical	30 mA + (3.5 x Nb) mA	
	maximum	40 mA + (3.5 x Nb) mA	
Dissipated power (1)		1 W + (0.1 x Nb) W	

Temperature downgrading (see page 77)	The characteristics at 60 °C are guaranteed for 60 % of inputs set to 1
Legend:	
(1)	Nb = number of channels at 1.

Connecting the TSX DEY 32D2K module

At a Glance

The **TSX DEY 32D2K** module comprises 32 x 24 VDC type 1 inputs.

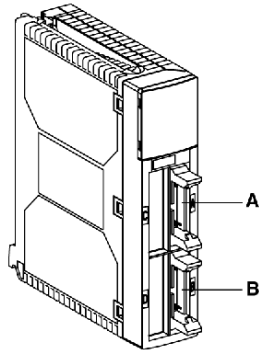

This module is fitted with 2 male **HE10** connectors:

- connector A for inputs 0 to 15;
- connector B for inputs 16 to 31.

Input circuit diagram

The circuit diagram for the inputs is shown below.

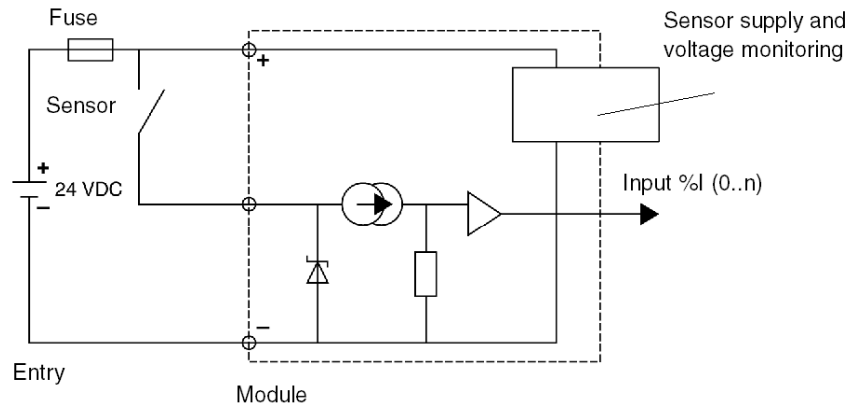

Module connection

The following diagram shows the connection of the module to the sensors.

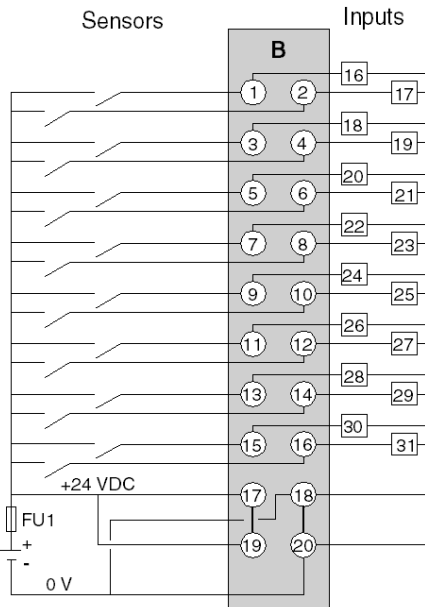
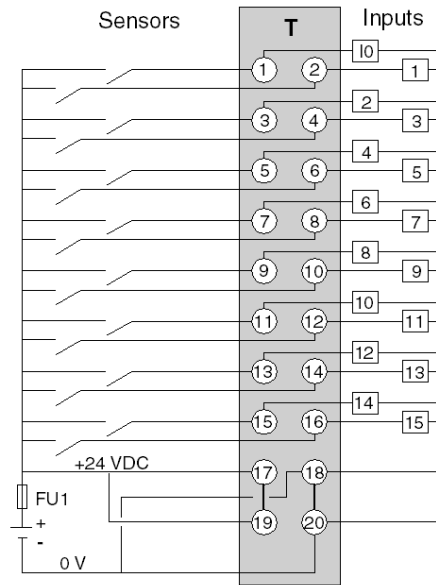

FU1 0.5 A quick-blow fuse

TSX DEY 32D3K Discrete input module

13

Overview

This chapter describes the **TSX DEY 32D3K** module, its characteristics and its connection to the different sensors.

What's in this Chapter?

This chapter contains the following topics:

Topic	Page
Presentation of the TSX DEY 32D3K module	132
Characteristics of the TSX DEY 32D3K module	133
Connecting the TSX DEY 32D3K module	135

Presentation of the TSX DEY 32D3K module

General

The **TSX DEY 32D3K** module

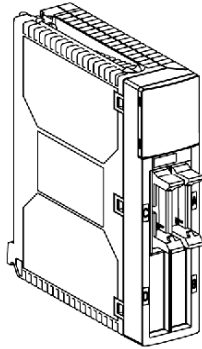

The **TSX DEY 32D3K** module is a 48 VDC 32-channel connector Discrete input module with positive logic.

Characteristics of the TSX DEY 32D3K module

At a Glance

This section provides a description of the general characteristics of the **TSX DEY 32D3K** module.

General characteristics

The following table shows the general characteristics of the **TSX DEY 32D3K** module:

The TSX DEY 32D3K module		48 VDC positive logic inputs	
Nominal input values		Voltage	48 VDC
		Current	7 mA
Threshold input values	at 1	Voltage	≥ 30 V
		Current	≥ 6.5 mA (for $U = 30$ V)
	at 0	Voltage	≤ 10 V
		Current	≤ 2 mA
Sensor supply (including ripple)		38..60 V	
Input impedance	at nominal U	6.3 kOhms	
Response time		4 ms	
IEC 1131-2 compliance		type 2	
2 wire / 3 wire proximity sensor compatibility (see page 50)		IEC 947-5-2	
Dielectric strength	Input / ground or Input / internal logic	1500 V actual, 50 / 60 Hz for 1 min	
Insulation resistance		> 10 MOhms (below 500 VDC)	
Type of input		current sink	
Paralleling of inputs		Yes	
Sensor voltage check threshold	OK	> 36 V	
	Error	< 24 V	
Check response time	on appearance	8 ms < T < 30 ms	
	on disappearance	1 ms < T < 3 ms	
5 V consumption	typical	300 mA	
	maximum	350 mA	
Sensor supply consumption (1)	typical	50 mA + (7 x Nb) mA	
	maximum	66 mA + (7 x Nb) mA	
Dissipated power (1)		2.5 W + (0.34 x Nb) W	

Temperature downgrading <i>(see page 77)</i>	The characteristics at 60 ° C are guaranteed for 60 % of inputs set to 1
Legend:	
(1)	Nb = number of channels at 1.

Connecting the TSX DEY 32D3K module

At a Glance

The **TSX DEY 32D3K** module comprises 32 x 48 VDC type 2 inputs.

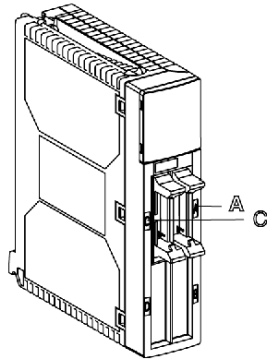

This module is fitted with 2 male **HE10** connectors:

- connector A for inputs 0 to 15;
- connector C for inputs 16 to 31.

Principle Diagram

The circuit diagram for an input is shown below.

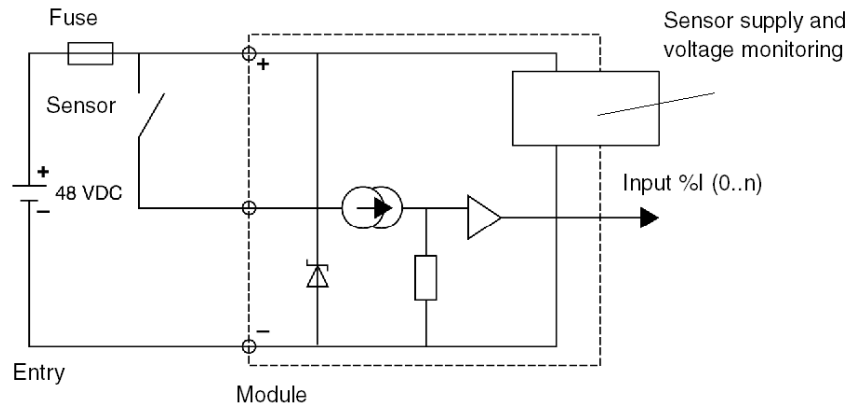

Module connection

The following diagram shows the connection of the module to the sensors.

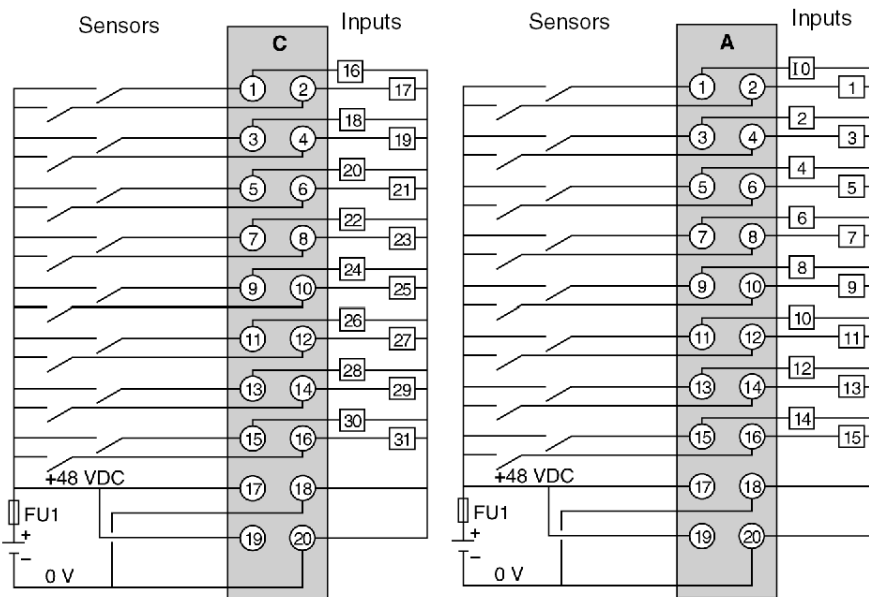

FU1 0.5 A quick-blow fuse

TSX DEY 64D2K Discrete input module

14

Overview

This chapter describes the **TSX DEY 64D2K** module, its characteristics and its connection to the different sensors.

What's in this Chapter?

This chapter contains the following topics:

Topic	Page
Presentation of the TSX DEY 64D2K module	138
Characteristics of the TSX DEY 64D2K module	139
Connecting the TSX DEY 64D2K module	141

Presentation of the TSX DEY 64D2K module

General

The **TSX DEY 64D2K** module

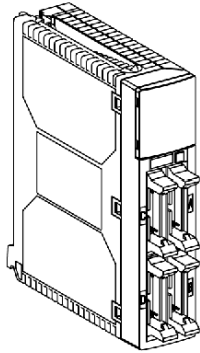

The **TSX DEY 64D2K** module is a 24 VDC 64-channel connector Discrete input module with positive logic.

Characteristics of the TSX DEY 64D2K module

At a Glance

This section provides a description of the general characteristics of the **TSX DEY 64D2K** module.

General characteristics

The following table shows the general characteristics of the **TSX DEY 64D2K** module:

The TSX DEY 64D2K module		24 VDC positive logic inputs	
Nominal input values		Voltage	24 VDC
		Current	3.5 mA
Threshold input values	at 1	Voltage	≥ 11 V
		Current	≥ 3 mA
	at 0	Voltage	≤ 5 V
		Current	≤ 1.5 mA
	Sensor supply (including ripple)		19..30 V (possibly up to 34 V, limited to 1 hour every 24 hours)
Input impedance	at nominal U	6.3 kOhms	
Response time		4 ms	
IEC 1131-2 compliance		type 1	
2 wire / 3 wire proximity sensor compatibility (see page 50)		IEC 947-5-2	
Dielectric strength	Input / ground or Input / internal logic	1500 V actual, 50 / 60 Hz for 1 min	
Insulation resistance		> 10 MOhms (below 500 VDC)	
Type of input		current sink	
Paralleling of inputs		No	
Sensor voltage check threshold	OK	> 18 V	
	Error	< 14 V	
Check response time	on appearance	8 ms < T < 30 ms	
	on disappearance	1 ms < T < 3 ms	
5 V consumption	typical	135 mA	
	maximum	175 mA	
Sensor supply consumption (1)	typical	60 mA + (3.5 x Nb) mA	
	maximum	80 mA + (3.5 x Nb) mA	
Dissipated power (1)		1.5 W + (0.1 x Nb) W	

Temperature downgrading (<i>see page 77</i>)	The characteristics at 60 °C are guaranteed for 60 % of inputs set to 1
Legend:	
(1)	Nb = number of channels at 1.

Connecting the TSX DEY 64D2K module

At a Glance

The **TSX DEY 64D2K** module comprises 64 x 24 VDC type 1 inputs.

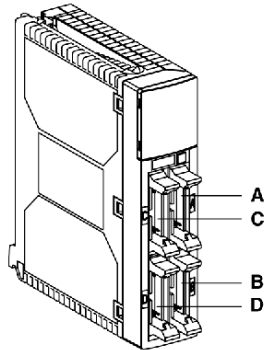

This module is fitted with 4 male **HE10** connectors:

- connector A for inputs 0 to 15;
- connector B for inputs 16 to 31;
- connector C for inputs 32 to 47;
- connector D for inputs 48 to 63.

Principle Diagram

The circuit diagram for an input is shown below.

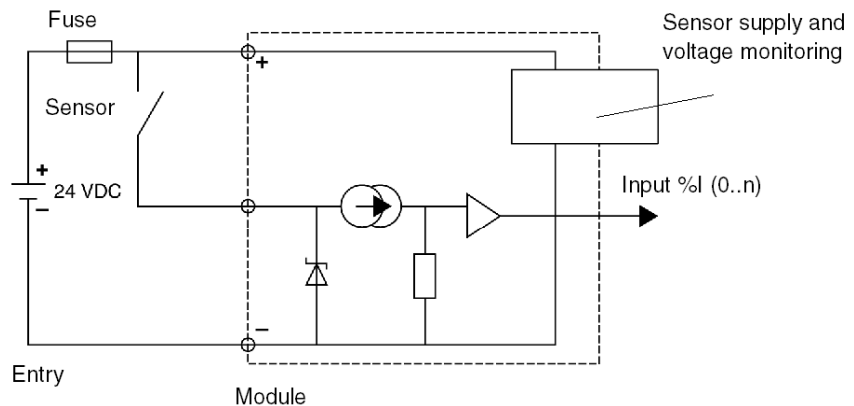

Module connection

The following diagram shows the connection of the module to the sensors.

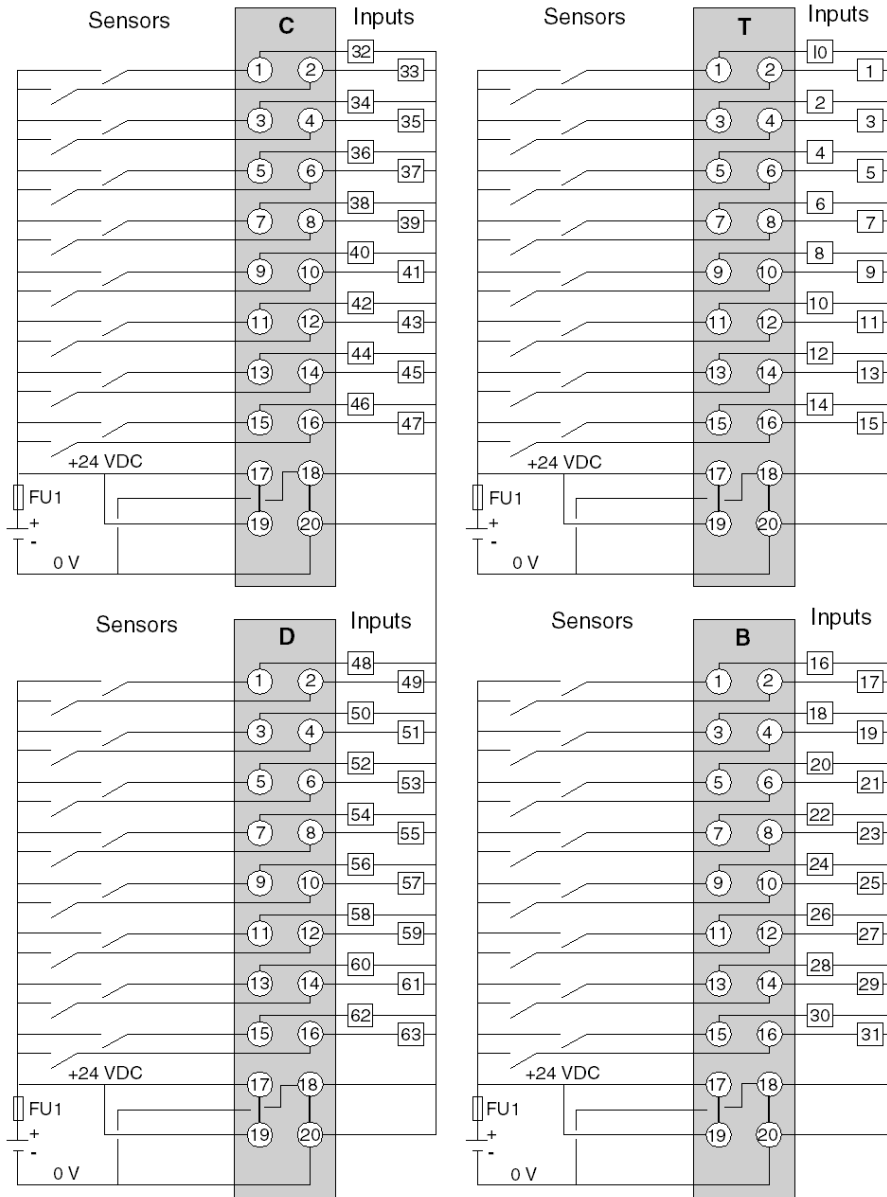

FU1 0.5 A quick-blow fuse

TSX DSY 08T2 output module

15

Overview

This chapter describes the **TSX DSY 08T2** module, its characteristics and its connection to the different pre-actuators.

What's in this Chapter?

This chapter contains the following topics:

Topic	Page
Presentation of the TSX DSY 08T2 module	144
Characteristics of the TSX DSY 08T2 module	145
Connecting the TSX DSY 08T2 module	147

Presentation of the TSX DSY 08T2 module

General

The **TSX DSY 08T2** module

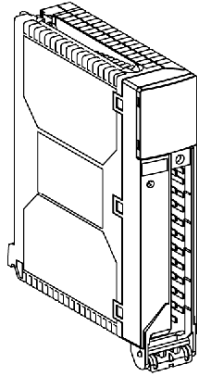

The **TSX DSY 08T2** module is an 8-channel terminal block Discrete transistor output module for direct current (positive logic).

Characteristics of the TSX DSY 08T2 module

At a Glance

This section provides a description of the general characteristics of the **TSX DSY 08T2** module.

General characteristics

The following table shows the general characteristics of the **TSX DSY 08T2** module:

The TSX DSY 08T2 module		24 VDC positive logic transistor outputs
Nominal values	Voltage	24 VDC
	Current	0.5 A
Threshold values (1)	Voltage (including ripple)	19..30 V (34 V possible for 1 hour every 24 hours)
	Current/channel	0.625 A
	Current/module	4 A
Power of tungsten filament lamp	Maximum	6 W
Leakage current	at 0	< 0.5 mA
Voltage drop	at 1	< 1.2 V
Load impedance	minimum	48 Ohms
Response time (2)		1.2 ms
Frequency of switching to inductive load		0.5 / $L I^2$ Hz
Paralleling of outputs		Yes (maximum of 2)
Compatibility with IEC 1131-2 DC inputs		Yes (type 1 and type2)
Built-in protection	against over-voltage	Yes, by Transil diode
	against inversions	Yes, by inverted diode (3)
	against short-circuits and overloads	Yes, by current limiter and electric circuit-breaker $1.5 I_n < I_d < 2 I_n$
Pre-actuator voltage check threshold	OK	> 18 V
	Error	< 14 V
Check response time	on appearance	T < 4 ms
	on disappearance	T < 30 ms
5 V consumption	typical	55 mA
	maximum	65 mA
24 V pre-actuator consumption (4)	typical	30 mA
	maximum	40 mA
Dissipated power (5)		1 W + (0.75 x Nb) W

Dielectric strength	Output / ground or Output / internal logic	1500 V actual, 50 / 60 Hz for 1 min
Insulation resistance		> 10 MOhms (below 500 VDC)
Temperature downgrading (<i>see page 77</i>)		The characteristics at 60 °C are guaranteed for 60 % of max. module current
Legend:		
(1)	For $U \leq 30$ V or 34 V.	
(2)	All the outputs are equipped with fast electromagnet demagnetization circuits. Electromagnet discharge time $< L/R$	
(3)	Fit a fuse to the +24 V pre-actuator supply.	
(4)	Excluding load current.	
(5)	Nb = number of outputs at 1.	

Connecting the TSX DSY 08T2 module

At a Glance

The **TSX DSY 08T2** module comprises 8 x 24 VDC protected transistor output channels.

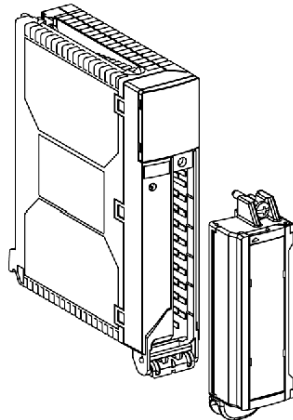

This module is equipped with a removable 20 post screwed connection terminal block, allowing outputs to be connected:

Circuit Diagram

The circuit diagram for an output is shown below.

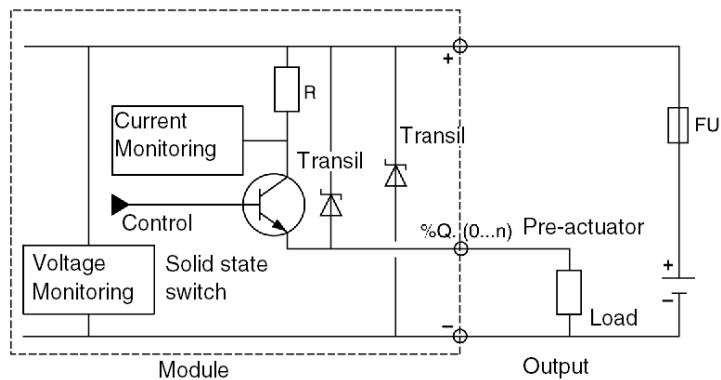

Module connection

The diagram below shows the connection of the module to the pre-actuators.

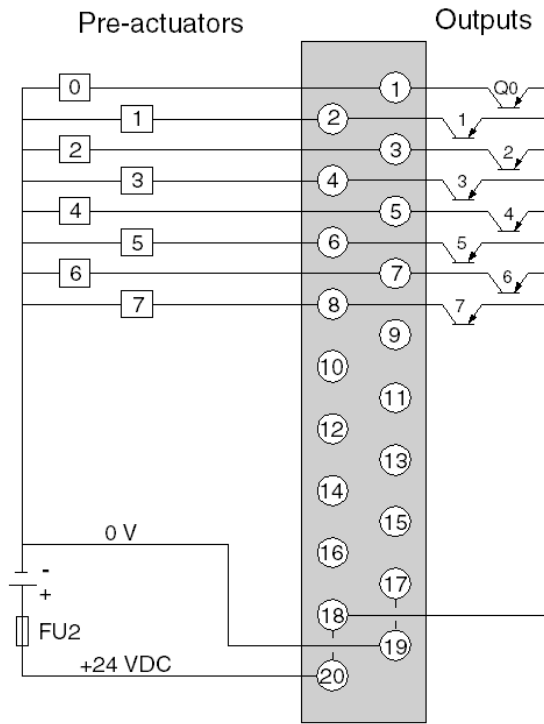

FU2 6.3 A quick-blow fuse

TSX DSY 08T22 Discrete output module

16

Overview

This chapter describes the **TSX DSY 08T22** module, its characteristics and its connection to the different pre-actuators.

What's in this Chapter?

This chapter contains the following topics:

Topic	Page
Presentation of the TSX DSY 08T22 module	150
Characteristics of the TSX DSY 08T22 module	151
Connecting the TSX DSY 08T22 module	153

Presentation of the TSX DSY 08T22 module

General

The **TSX DSY 08T22** module

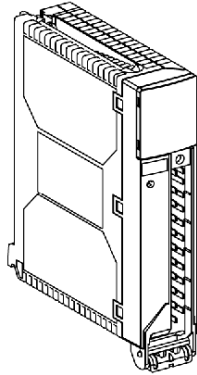

The **TSX DSY 08T22** module is an 8-channel terminal block Discrete transistor output module for direct current (positive logic).

Characteristics of the TSX DSY 08T22 module

At a Glance

This section provides a description of the general characteristics of the **TSX DSY 08T22** module.

General characteristics

The following table shows the general characteristics of the **TSX DSY 08T22** module:

The TSX DSY 08T22 module		24 VDC positive logic transistor outputs
Nominal values	Voltage	24 VDC
	Current	2 A
Threshold values (1)	Voltage (including ripple)	19..30 V (34 V possible for 1 hour every 24 hours)
	Current/channel	2.5 A
	Current/module	14 A
Power of tungsten filament lamp	Maximum	10 W
Leakage current	at 0	< 1 mA
Voltage drop	at 1	< 0.5 V
Load impedance	minimum	12 Ohms
Response time (2)		200 micros
Frequency of switching to inductive load		0.5 / LI ² Hz
Paralleling of outputs		Yes (maximum of 2)
Compatibility with IEC 1131-2 DC inputs		Yes (type 1 and type 2)
Built-in protection	against over-voltage	Yes, by Transil diode
	against inversions	Yes, by inverted diode (3)
	against short-circuits and overloads	Yes, by current limiter and electric circuit-breaker 1.5 I _n < I _d < 2 I _n
Pre-actuator voltage check threshold	OK	> 18 V
	Error	< 14 V
Check response time	on appearance	T < 4 ms
	on disappearance	T < 30 ms
5 V consumption	typical	55 mA
	maximum	65 mA
24 V pre-actuator consumption (4)	typical	30 mA
	maximum	50 mA

Dissipated power (5)		1.3 W + (0.2 x Nb) W
Dielectric strength	Output / ground or Output / internal logic	1500 V actual, 50 / 60 Hz for 1 min
Insulation resistance		> 10 MOhms (below 500 VDC)
Temperature downgrading (see page 77)		The characteristics at 60 °C are guaranteed for 60 % of max. module current
Legend:		
(1)	For U ≤30 V or 34 V.	
(2)	All the outputs are equipped with fast electromagnet demagnetization circuits. Electromagnet discharge time < L/R	
(3)	Fit a fuse to the +24 V pre-actuator supply.	
(4)	Excluding load current.	
(5)	Nb = number of outputs at 1.	

Connecting the TSX DSY 08T22 module

At a Glance

The **TSX DSY 08T22** module comprises 8 x 24 VDC protected transistor output channels.

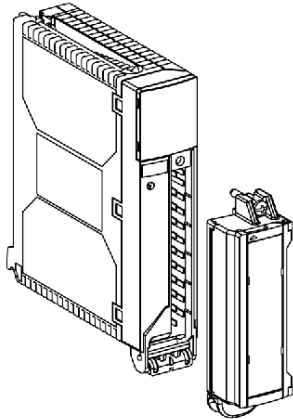

This module is equipped with a removable 20 post screwed connection terminal block, allowing outputs to be connected:

Circuit Diagram

The circuit diagram for an output is shown below.

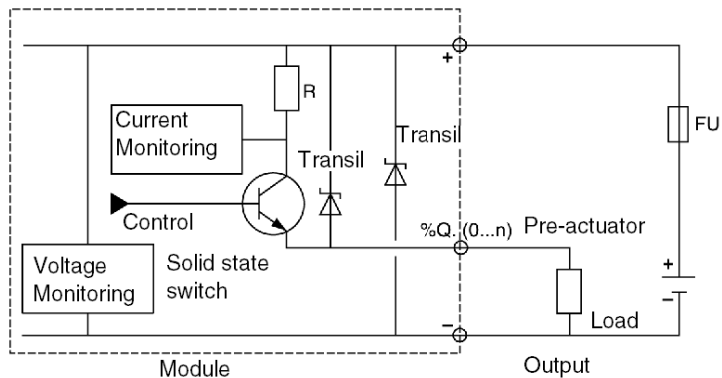

Module connection

The diagram below shows the connection of the module to the pre-actuators.

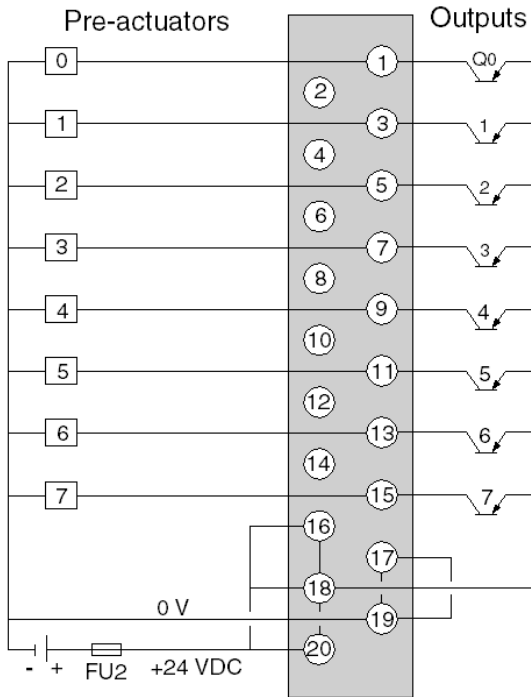

FU2 16 A quick-blow fuse

TSX DSY 08T31 Discrete output module

17

Overview

This chapter describes the **TSX DSY 08T31** module, its characteristics and its connection to the different pre-actuators.

What's in this Chapter?

This chapter contains the following topics:

Topic	Page
Presentation of the TSX DSY 08T31 module	156
Characteristics of the TSX DSY 08T31 module	157
Connecting the TSX DSY 08T31 module	159

Presentation of the TSX DSY 08T31 module

General

The **TSX DSY 08T31** module

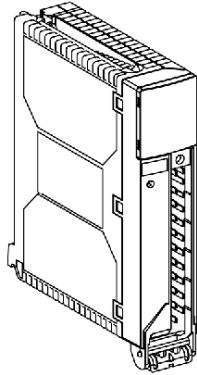

The **TSX DSY 08T31** module is an 8-channel terminal block Discrete transistor output module for direct current (positive logic).

Characteristics of the TSX DSY 08T31 module

At a Glance

This section provides a description of the general characteristics of the **TSX DSY 08T31** module.

General characteristics

The following table shows the general characteristics of the **TSX DSY 08T31** module:

The TSX DSY 08T31 module		24 VDC positive logic transistor outputs
Nominal values	Voltage	48 VDC
	Current	1 A
Threshold values (1)	Voltage (including ripple)	38..60 V
	Current/channel	1.25 A
	Current/module	7 A
Power of tungsten filament lamp	Maximum	10 W
Leakage current	at 0	< 1 mA
Voltage drop	at 1	< 1 V
Load impedance	minimum	48 Ohms
Response time (2)		200 micros
Frequency of switching to inductive load		0.5 / LI ² Hz
Paralleling of outputs		Yes (maximum of 2)
Compatibility with IEC 1131-2 DC inputs		Yes (type 1 and type 2)
Built-in protection	against over-voltage	Yes, by Transil diode
	against inversions	Yes, by inverted diode (3)
	against short-circuits and overloads	Yes, by current limiter and electric circuit-breaker 1.5 In < Id < 2 In
Pre-actuator voltage check threshold	OK	> 36 V
	Error	< 24 V
Check response time	on appearance	T < 4 ms
	on disappearance	T < 30 ms
5 V consumption	typical	55 mA
	maximum	65 mA
24 V pre-actuator consumption (4)	typical	30 mA
	maximum	50 mA

Dissipated power (5)		2.2 W + (0.55 x Nb) W
Dielectric strength	Output / ground or Output / internal logic	1500 V actual, 50 / 60 Hz for 1 min
Insulation resistance		> 10 MOhms (below 500 VDC)
Temperature downgrading (see page 77)		The characteristics at 60 °C are guaranteed for 60 % of max. module current
Legend:		
(1)	For U ≤30 V or 34 V.	
(2)	All the outputs are equipped with fast electromagnet demagnetization circuits. Electromagnet discharge time < L/R	
(3)	Fit a fuse to the +48 V pre-actuator supply.	
(4)	Excluding load current.	
(5)	Nb = number of outputs at 1.	

Connecting the TSX DSY 08T31 module

At a Glance

The **TSX DSY 08T31** module comprises 8 x 48 VDC protected transistor output channels.

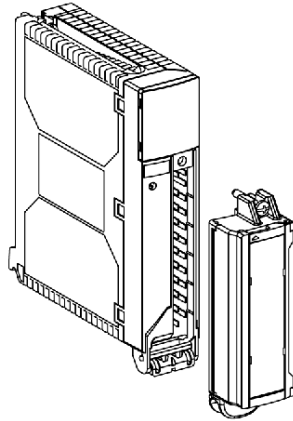

This module is equipped with a removable 20 post screwed connection terminal block, allowing outputs to be connected:

Circuit Diagram

The circuit diagram for an output is shown below.

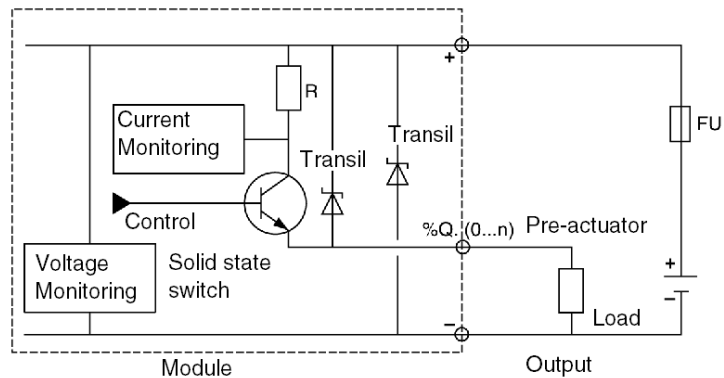

Module connection

The diagram below shows the connection of the module to the pre-actuators.

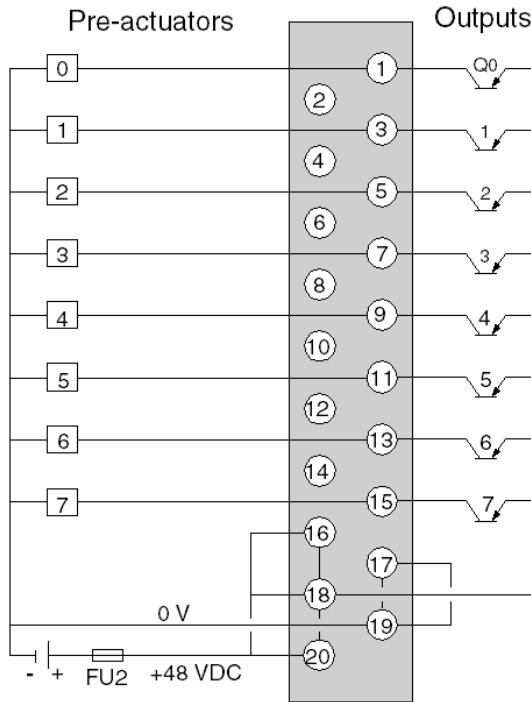

FU2 10 A quick-blow fuse

TSX DSY 16T2 Discrete output module

18

Overview

This chapter describes the **TSX DSY 16T2** module, its characteristics and its connection to the different pre-actuators.

What's in this Chapter?

This chapter contains the following topics:

Topic	Page
Presentation of the TSX DSY 16T2 module	162
Characteristics of the TSX DSY 16T2 module	163
Connecting the TSX DSY 16T2 module	165

Presentation of the TSX DSY 16T2 module

General

The **TSX DSY 16T2** module

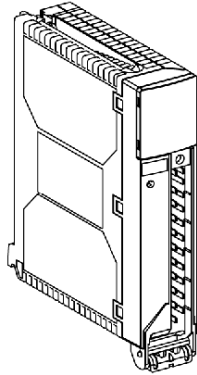

The **TSX DSY 16T2** module is an 16-channel terminal block Discrete transistor output module for direct current (positive logic).

Characteristics of the TSX DSY 16T2 module

At a Glance

This section provides a description of the general characteristics of the **TSX DSY 16T2** module.

General characteristics

The following table shows the general characteristics of the **TSX DSY 16T2** module:

The TSX DSY 16T2 module		24 VDC positive logic transistor outputs
Nominal values	Voltage	24 VDC
	Current	0.5 A
Threshold values (1)	Voltage (including ripple)	19..30 V (34 V possible for 1 hour every 24 hours)
	Current/channel	0.625 A
	Current/module	7 A
Power of tungsten filament lamp	Maximum	6 W
Leakage current	at 0	< 0.5 mA
Voltage drop	at 1	< 1.2 V
Load impedance	minimum	48 Ohms
Response time (2)		1.2 ms
Frequency of switching to inductive load		$0.5 / L I^2$ Hz
Paralleling of outputs		Yes (maximum of 2)
Compatibility with IEC 1131-2 DC inputs		Yes (type 1 and type 2)
Built-in protection	against over-voltage	Yes, by Transil diode
	against inversions	Yes, by inverted diode (3)
	against short-circuits and overloads	Yes, by current limiter and electric circuit-breaker $1.5 I_n < I_d < 2 I_n$
Pre-actuator voltage check threshold	OK	> 18 V
	Error	< 14 V
Check response time	on appearance	$T < 4$ ms
	on disappearance	$T < 30$ ms
5 V consumption	typical	80 mA
	maximum	90 mA
24 V pre-actuator consumption (4)	typical	40 mA
	maximum	60 mA
Dissipated power (5)		$1.1 \text{ W} + (0.75 \times N_b) \text{ W}$

Dielectric strength	Output / ground or Output / internal logic	1500 V actual, 50 / 60 Hz for 1 min
Insulation resistance		> 10 MOhms (below 500 VDC)
Temperature downgrading (<i>see page 77</i>)		The characteristics at 60 °C are guaranteed for 60 % of max. module current
Legend:		
(1)	For $U \leq 30$ V or 34 V.	
(2)	All the outputs are equipped with fast electromagnet demagnetization circuits. Electromagnet discharge time $< L/R$	
(3)	Fit a fuse to the + 24 V pre-actuator supply.	
(4)	Excluding load current.	
(5)	Nb = number of outputs at 1.	

Connecting the TSX DSY 16T2 module

At a Glance

The **TSX DSY 16T2** module comprises 16 x 24 VDC protected transistor output channels.

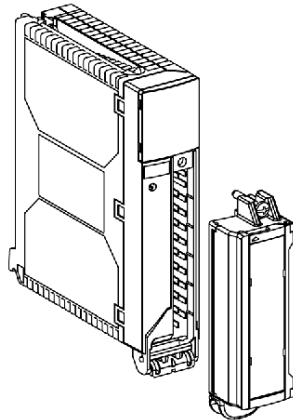

This module is equipped with a removable 20 post screwed connection terminal block, allowing outputs to be connected:

Circuit Diagram

The circuit diagram for an output is shown below.

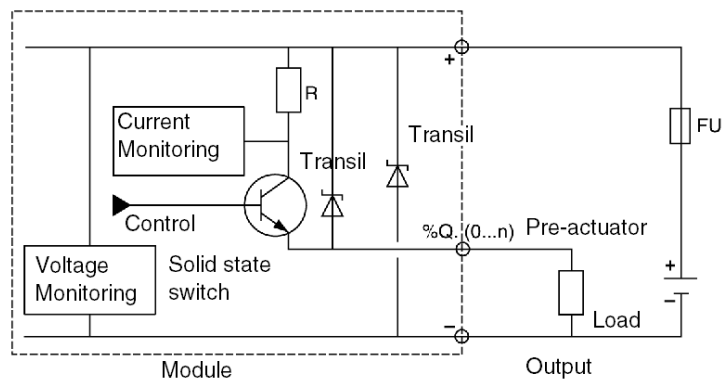

Module connection

The diagram below shows the connection of the module to the pre-actuators.

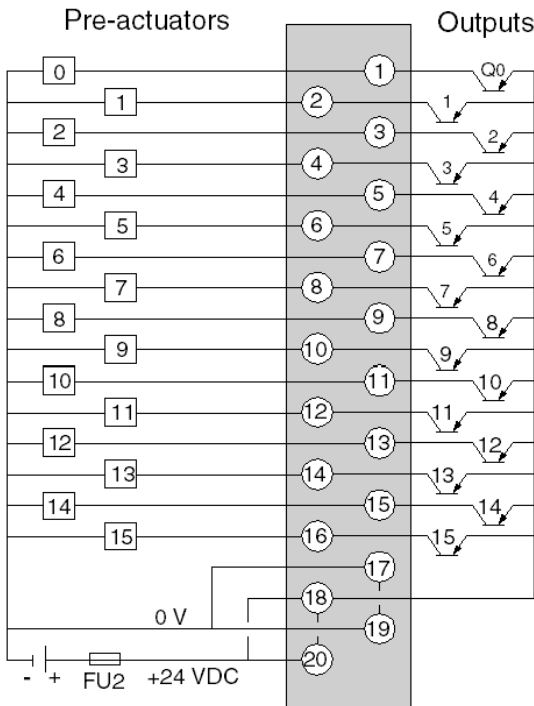

FU2 6.3 A quick-blow fuse

TSX DSY 16T3 Discrete output module

19

Subject of this chapter

This chapter describes the **TSX DSY 16T3** module, its characteristics and its connection to the different pre-actuators.

What's in this Chapter?

This chapter contains the following topics:

Topic	Page
Presentation of the TSX DSY 16T3 module	168
Characteristics of the TSX DSY 16T3 module	169
Connecting the TSX DSY 16T3 module	171

Presentation of the TSX DSY 16T3 module

General

The **TSX DSY 16T3** module

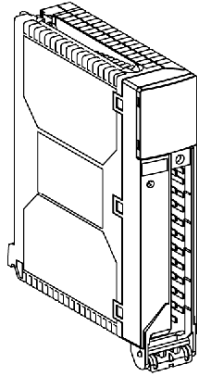

The **TSX DSY 16T3** module is a 16-channel terminal block Discrete transistor output module for direct current (positive logic).

Characteristics of the TSX DSY 16T3 module

At a Glance

This section provides a description of the general characteristics of the **TSX DSY 16T3** module.

General characteristics

The following table shows the general characteristics of the **TSX DSY 16T3** module:

The TSX DSY 16T3 module		48 VDC positive logic transistor outputs
Nominal values	Voltage	48 VDC
	Current	0.25 A
Threshold values (1)	Voltage (including ripple)	38..60 V
	Current/channel	0.31 A
	Current/module	4 A
Power of tungsten filament lamp	Maximum	6 W
Leakage current	at 0	< 0.5 mA
Voltage drop	at 1	< 1.5 V
Load impedance	minimum	192 Ohms
Response time (2)		1.2 ms
Frequency of switching to inductive load		0.5 / LI ² Hz
Paralleling of outputs		Yes (maximum of 2)
Compatibility with IEC 1131-2 DC inputs		Yes (type 1 and type 2)
Built-in protection	against over-voltage	Yes, by Transil diode
	against inversions	Yes, by inverted diode (3)
	against short-circuits and overloads	Yes, by current limiter and electric circuit-breaker 1.5 I _n < I _d < 2 I _n
Pre-actuator voltage check threshold	OK	> 36 V
	Error	< 24 V
Check response time	on appearance	T < 4 ms
	on disappearance	T < 30 ms
5 V consumption	typical	80 mA
	maximum	90 mA
24 V pre-actuator consumption (4)	typical	40 mA
	maximum	60 mA
Dissipated power (5)		2.4 W + (0.85 x Nb) W

Dielectric strength	Output / ground or Output / internal logic	1500 V actual, 50 / 60 Hz for 1 min
Insulation resistance		> 10 MOhms (below 500 VDC)
Temperature downgrading (<i>see page 77</i>)		The characteristics at 60 °C are guaranteed for 60 % of max. module current
Legend:		
(1)	For $U \leq 30$ V or 34 V	
(2)	All the outputs are equipped with fast electromagnet demagnetization circuits. Electromagnet discharge time < L/R	
(3)	Fit a fuse to the +48 V pre-actuator supply.	
(4)	Excluding load current.	
(5)	Nb = number of outputs at 1.	

Connecting the TSX DSY 16T3 module

At a Glance

The **TSX DSY 16T3** module comprises 16 x 48 VDC protected transistor output channels.

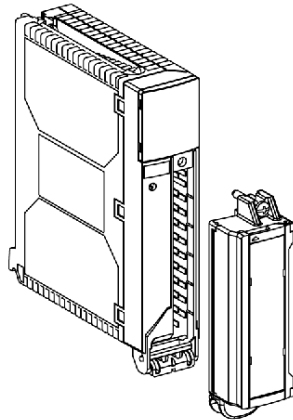

This module is equipped with a removable 20 post screwed connection terminal block, allowing outputs to be connected:

Circuit Diagram

The circuit diagram for an output is shown below.

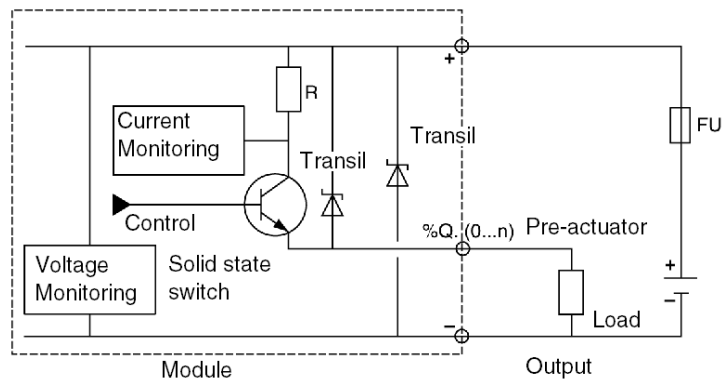

Module connection

The diagram below shows the connection of the module to the pre-actuators.

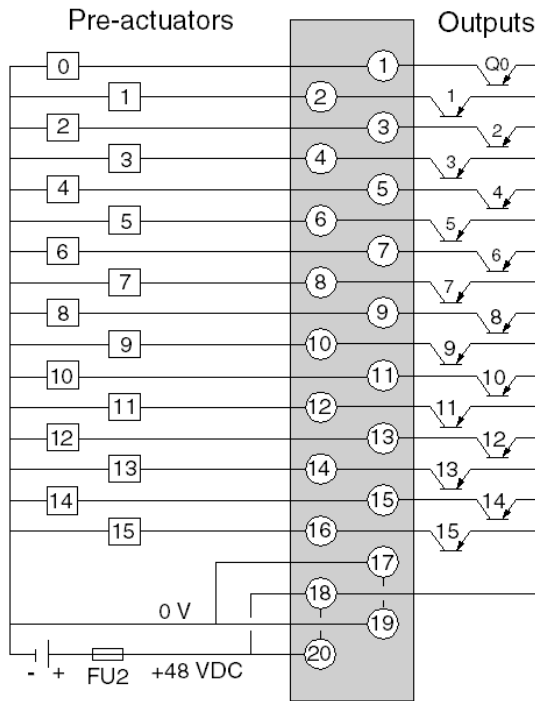

FU2 10 A quick-blow fuse

TSX DSY 08R5 Discrete output module

20

Overview

This chapter describes the **TSX DSY 08R5** module, its characteristics and its connection to the different pre-actuators.

What's in this Chapter?

This chapter contains the following topics:

Topic	Page
Presentation of the TSX DSY 08R5 module	174
Relay output contact protection	175
Characteristics of the TSX DSY 08R5 module	176
Connecting the TSX DSY 08R5 module	178

Presentation of the TSX DSY 08R5 module

General

The **TSX DSY 08R5** module

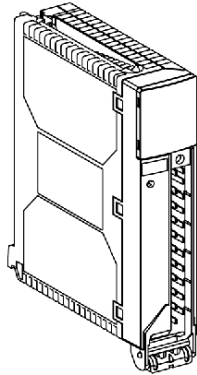

The **TSX DSY 08R5** module is an 8-channel terminal block Discrete relay output module for 3 A thermal current.

Relay output contact protection

At a Glance

The outputs of the Discrete modules **TSX DSY 08R5** and **TSX DSY 16R5** do not feature any contact protection; it is therefore necessary to take the following precautions.

Precautions

These relay outputs feature no protective measures, in order to make it possible to control the following:

- galvanic insulated inputs - at low energy level and requiring zero leakage current,
- power circuits, whilst eliminating inductive over-voltages at the source.

It is therefore obligatory to mount the following on the pre-actuator coil terminals:

- an RC circuit or a MOV (ZNO) peak limiter for use with alternating current,
- a discharge diode for use with direct current.

NOTE: a relay output that has been used with an alternating current load must not be then used with direct current, and vice versa.

Characteristics of the TSX DSY 08R5 module

At a Glance

This section provides a description of the general characteristics of the **TSX DSY 08R5** module.

General characteristics

The following table shows the general characteristics of the **TSX DSY 08R5** module:

The TSX DSY 08R5 module		3 A thermal current relay outputs					
Threshold service voltage <i>(see page 77)</i>	Direct	10..34 VDC					
	Alternating	19..264 VAC					
Thermal current		3 A					
Maximum current per common		3 A (value not to be exceeded)					
Alternating current load	Resistive AC12	Voltage	24 V	48 V	100..120 V	200..240 V	
		Power	50 VA (5)	50 VA (6) 110 VA (4)	110 VA (6) 220 VA (4)	220 VA (6)	
	Inductive AC14 and AC15	Voltage	24 V	48 V	100..120 V	200..240 V	
		Power	24 VA (4)	10 VA (10) 24 VA (8)	10 VA (11) 50 VA (7) 110 VA (2)	10 VA (11) 50 VA (9) 110 VA (6) 220 VA (1)	
	Direct current load	Resistive DC12	Voltage	24 V			
			Power	24 W (6) 40 W (3)			
Inductive DC13 (L/R = 60 ms)		Voltage	24 V				
		Power	10 W (8) 24 W (6)				
Minimum switchable load		1 mA / 5 V					
Response time		Activation	< 8 ms				
	Deactivation	< 10 ms					
Type of contact		normally open					

Built-in protection	against short-circuits and overloads		None, compulsory installation of a quick-blow fuse on every channel or channel group.
	against inductive overloads with alternating current		None, compulsory installation – in parallel to the terminals of each pre-actuator - of a RC circuit or MOV (ZNO) peak limiter, appropriate to the voltage in use.
	against inductive overloads with direct current		None, compulsory installation of a discharge diode at the terminals of each pre-actuator.
Dissipated power (12)			0.25 W + (0.2 x Nb) W
Dielectric strength	Output / ground or Output / internal logic		2000 V actual, 50 / 60 Hz for 1 min
Insulation resistance			> 10 MOhms (below 500 VDC)
Power supply consumption	5 V internal	Typical	55 mA
		Maximum	65 mA
	24 V relay (13)	Typical	8.5 mA
		Maximum	10 mA
Legend:			
(1)	0.1 x 10 ⁶ maneuvers		
(2)	0.15 x 10 ⁶ maneuvers		
(3)	0.3 x 10 ⁶ maneuvers		
(4)	0.5 x 10 ⁶ maneuvers		
(5)	0.7 x 10 ⁶ maneuvers		
(6)	1 x 10 ⁶ maneuvers		
(7)	1.5 x 10 ⁶ maneuvers		
(8)	2 x 10 ⁶ maneuvers		
(9)	3 x 10 ⁶ maneuvers		
(10)	5 x 10 ⁶ maneuvers		
(11)	10 x 10 ⁶ maneuvers		
(12)	Nb = number of outputs at 1.		
(13)	Per channel at 1		

Connecting the TSX DSY 08R5 module

At a Glance

The **TSX DSY 08R5** module comprises 8 relay output channels for 3 A thermal current.

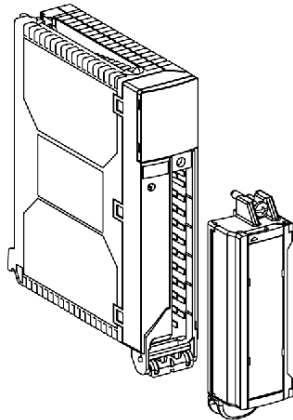

This module is equipped with a removable 20 post screwed connection terminal block, allowing outputs to be connected:

Circuit Diagram

The circuit diagram for an output is shown below.

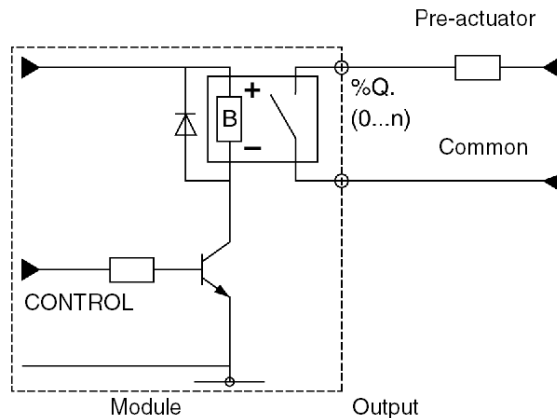

Module connection

The diagram below shows the connection of the module to the pre-actuators.

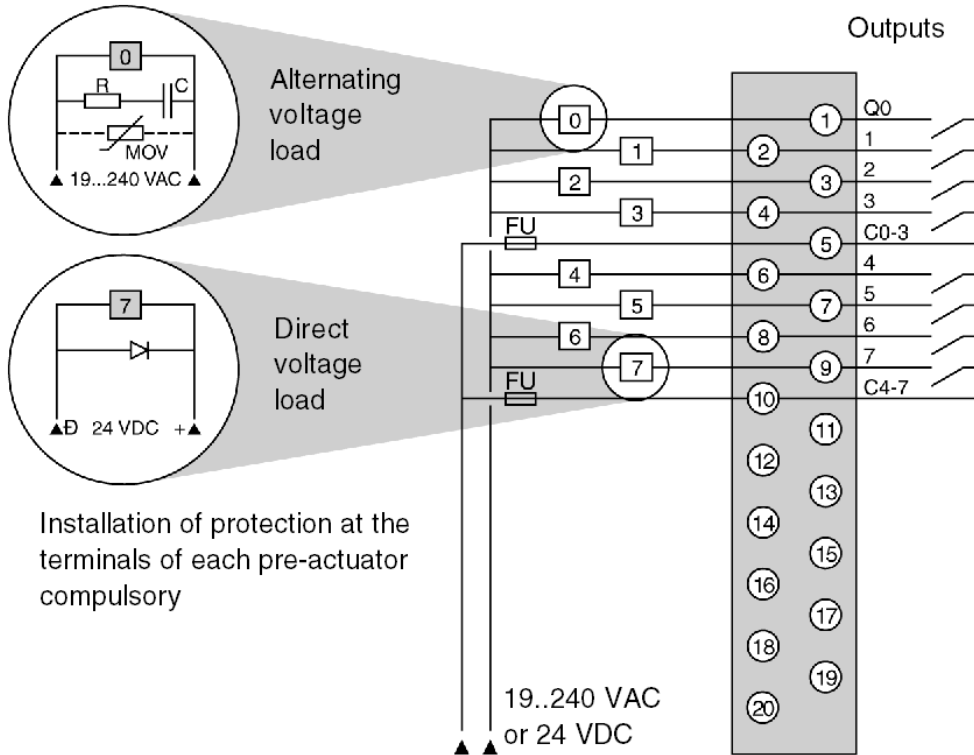

TSX DSY 08R4D Discrete output module

21

Overview

This chapter describes the **TSX DSY 08R4D** module, its characteristics and its connection to the different pre-actuators.

What's in this Chapter?

This chapter contains the following topics:

Topic	Page
Presentation of the TSX DSY 08R4D module	182
Fuse protection	183
Connecting the TSX DSY 08R4D module	184
Characteristics of the TSX DSY 08R4D module	186

Presentation of the TSX DSY 08R4D module

General

The **TSX DSY 08R4D** module

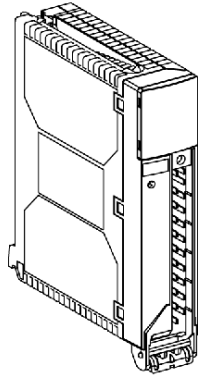

The **TSX DSY 08R4D** module is an 8-channel terminal block Discrete relay output module for direct current.

Fuse protection

At a Glance

The Discrete output models **TSX DSY 08R5A**, **TSX DSY 08R4D**, **TSX DSY 08S5** and **TSX DSY 16S5** are supplied with interchangeable fuses which can be accessed from the front panel of the modules, once the terminal block is removed.

Illustration

The following diagram shows the location of the contact protection fuses.

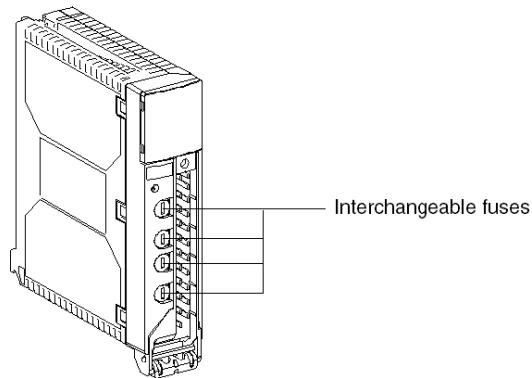

Description

The fuses can be accessed by removing the terminal block.

If a fuse is faulty, the diagnostics are displayed on the front panel of the module. The **I/O LED** is on.

Connecting the TSX DSY 08R4D module

At a Glance

The **TSX DSY 08R4D** module comprises 8 x protected relay output channels for direct current.

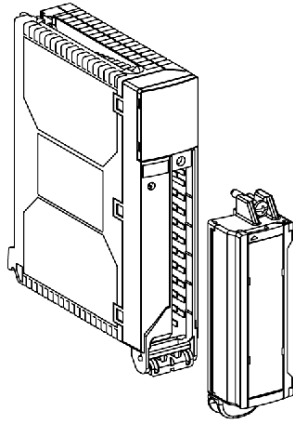

This module is equipped with a removable 20 post screwed connection terminal block, allowing outputs to be connected:

Circuit Diagram

The circuit diagram for an idle / operation output is shown below.

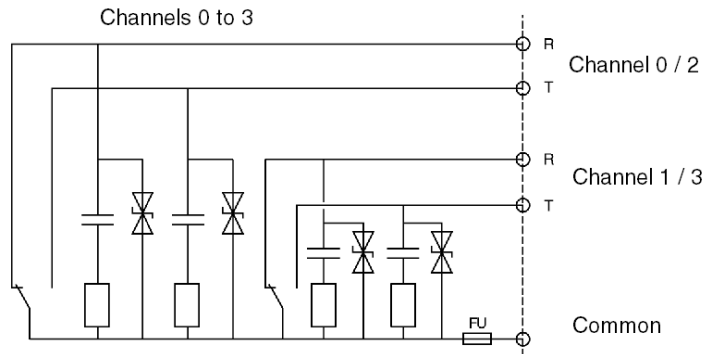

R Idle

T Operation

FU Quick-blow interchangeable 6.3 A fuse 1 fuse per common.

Circuit Diagram

The circuit diagram for an operation output is shown below.

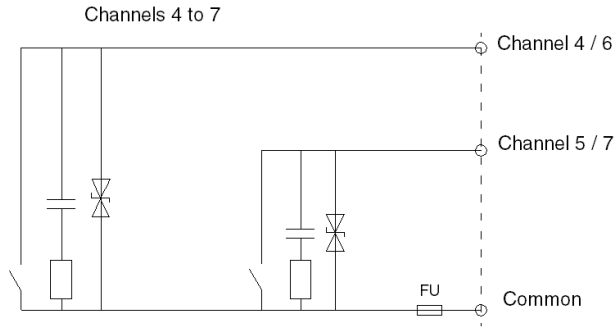

FU Quick-blow interchangeable 6.3 A fuse 1 fuse per common.

Module connection

The diagram below shows the connection of the module to the pre-actuators.

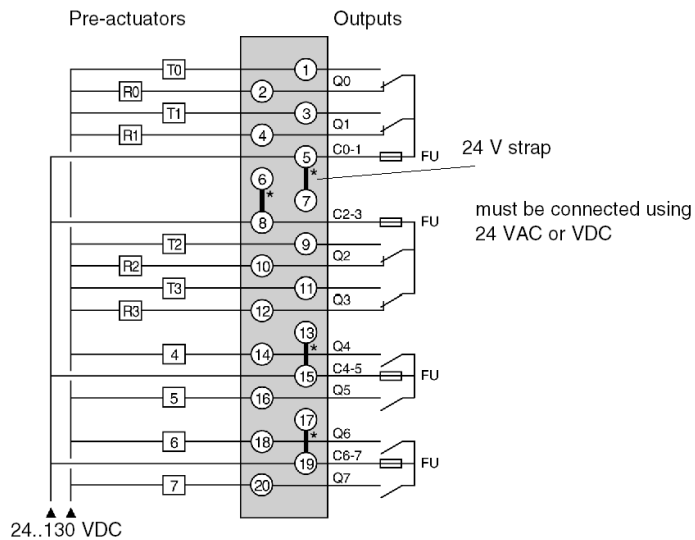

FU 6.3 A quick-blow fuse

Characteristics of the TSX DSY 08R4D module

At a Glance

This section provides a description of the general characteristics of the **TSX DSY 08R4D** module.

General characteristics

The following table shows the general characteristics of the **TSX DSY 08R4D** module:

The TSX DSY 08R4D module		Relay outputs for direct current			
Threshold service voltage (see page 77)	Direct	19..143 V			
	Alternating	prohibited			
Thermal current		5 A			
Maximum current per common		6 A (value not to be exceeded)			
Direct current load	Resistive DC12	Voltage	24 V	48 V	100..130 V
		Power	50 W (4) 100 W (2)	100 W (4) 200 W (2)	220 W (2) 440 W (1)
	Inductive DC13 (L/R = 60 ms)	Voltage	24 V	48 V	100..130 V
		Power	20 W (5) 50 W (4)	50 W (5) 100 W (4)	110 W (3) 220 W (2)
Response time	Activation	< 10 ms			
	Deactivation	< 15 ms			
Type of contact (6)		2 x 2 O/C 2 x 2 C			
Built-in protection	against over-voltage	R-C and Ge-Mov circuit			
	against short-circuits and overloads	6.3 A interchangeable quick-blow fuse per common			
Dissipated power (7)		0.25 W + (0.24 x Nb) W			
Dielectric strength	Output / ground or Output / internal logic	2000 V actual, 50 / 60 Hz for 1 min			
Insulation resistance		> 10 MOhms (below 500 VDC)			

Power supply consumption	5 V	Typical	55 mA
		Maximum	65 mA
	24 V relay (8)	Typical	10 mA
		Maximum	12 mA
Legend:			
(1)	0.15 x 10 ⁶ maneuvers		
(2)	0.3 x 10 ⁶ maneuvers		
(3)	0.5 x 10 ⁶ maneuvers		
(4)	1 x 10 ⁶ maneuvers		
(5)	2 x 10 ⁶ maneuvers		
(6)	O = open (idle); C = closed (operation)		
(7)	Nb = number of outputs at 1.		
(8)	Per channel at 1.		

TSX DSY 08R5A Discrete output module

22

Overview

This chapter describes the **TSX DSY 08R5A** module, its characteristics and its connection to the different pre-actuators.

What's in this Chapter?

This chapter contains the following topics:

Topic	Page
Presentation of the TSX DSY 08R5A module	190
Characteristics of the TSX DSY 08R5A module	191
Connecting the TSX DSY 08R5A module	193

Presentation of the TSX DSY 08R5A module

General

The **TSX DSY 08R5A** module

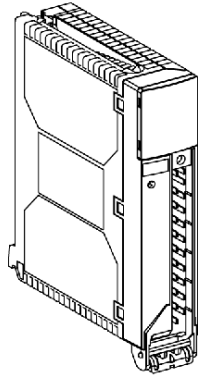

The **TSX DSY 08R5A** module is an 8-channel terminal block Discrete relay output module for 5 A thermal current.

This module features protection of contacts by interchangeable fuses (*see page 183*).

Characteristics of the TSX DSY 08R5A module

At a Glance

This section provides a description of the general characteristics of the **TSX DSY 08R5A** module.

General characteristics

The following table shows the general characteristics of the **TSX DSY 08R5A** module:

The TSX DSY 08R5A module			5 A thermal current relay outputs				
Threshold service voltage (see page 77)	Direct	19..60 V					
	Alternating	19..264 V					
Thermal current			5 A				
Maximum current per common			6 A (value not to be exceeded)				
Alternating current load	Resistive AC12	Voltage	24 V	48 V	100..120 V	200..240 V	
		Power	100 VA (5)	100 VA (6) 200 VA (4)	220 VA (6) 440 VA (4)	440 VA (6)	
	Inductive AC14 and AC15	Voltage	24 V	48 V	100..120 V	200..240 V	
		Power	50 VA (4)	20 VA (10) 50 VA (8)	20 VA (11) 110 VA (7) 220 VA (2)	20 VA (11) 110 VA (9) 220 VA (6) 440 VA (1)	
	Direct current load	Resistive DC12	Voltage	24 V	48 V	-	-
			Power	24 W (6) 50 W (3)	50W (6) 100 W (3)	-	-
Inductive DC13 (L/R = 60 ms)		Voltage	24 V	48 V	-	-	
		Power	10 W (8) 24 W (6)	24 W (8) 50 W (6)	-	-	
Response time	Activation	< 10 ms					
	Deactivation	< 15 ms					
Type of contact (12)			2 x 2 O/C 2 x 2 C				
Built-in protection	against over-voltage	R-C and Ge-Mov circuit					
	against short-circuits and overloads	6.3 A interchangeable quick-blow fuse per common					
Dissipated power (13)			0.25 W + (0.24 x Nb) W				
Dielectric strength	Output / ground or Output / internal logic	2000 V actual, 50 / 60 Hz for 1 min					

Insulation resistance			> 10 MOhms (below 500 VDC)
Power supply consumption	5 V	Typical	55 mA
		Maximum	65 mA
	24 V relay (14)	Typical	10 mA
		Maximum	12 mA
Legend:			
(1)	0.1 x 10 ⁶ maneuvers		
(2)	0.15 x 10 ⁶ maneuvers		
(3)	0.3 x 10 ⁶ maneuvers		
(4)	0.5 x 10 ⁶ maneuvers		
(5)	0.7 x 10 ⁶ maneuvers		
(6)	1 x 10 ⁶ maneuvers		
(7)	1.5 x 10 ⁶ maneuvers		
(8)	2 x 10 ⁶ maneuvers		
(9)	3 x 10 ⁶ maneuvers		
(10)	5 x 10 ⁶ maneuvers		
(11)	10 x 10 ⁶ maneuvers		
(12)	O = open (idle); C = closed (operation)		
(13)	Nb = number of outputs at 1.		
(14)	Per channel at 1.		

Connecting the TSX DSY 08R5A module

At a Glance

The **TSX DSY 08R5A** module comprises 8 protected relay output channels for 5 A thermal current.

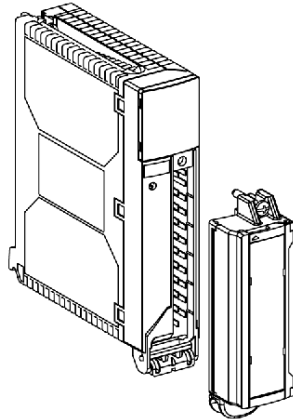

This module is equipped with a removable 20 post screwed connection terminal block, allowing outputs to be connected:

Circuit Diagram

The circuit diagram for an idle / operation output is shown below.

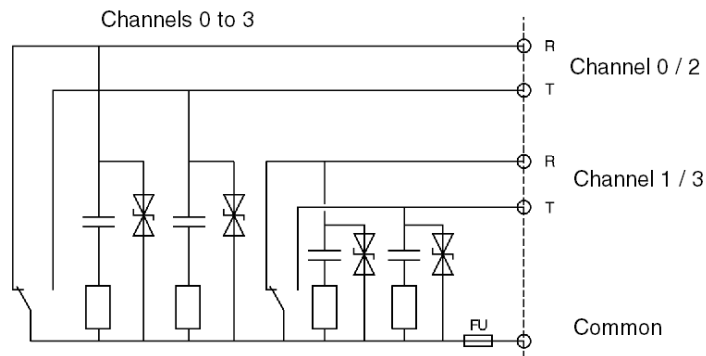

R Idle

T Operation

FU Quick-blow interchangeable 6.3 A fuse 1 fuse per common.

Circuit Diagram

The circuit diagram for an operation output is shown below.

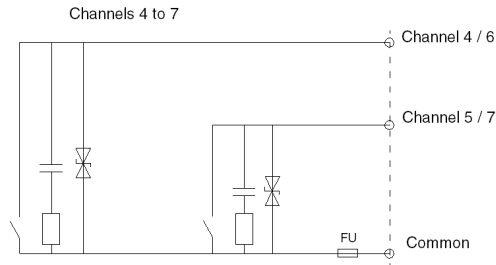

FU Quick-blow interchangeable 6.3 A fuse 1 fuse per common.

Module connection

The diagram below shows the connection of the module to the pre-actuators.

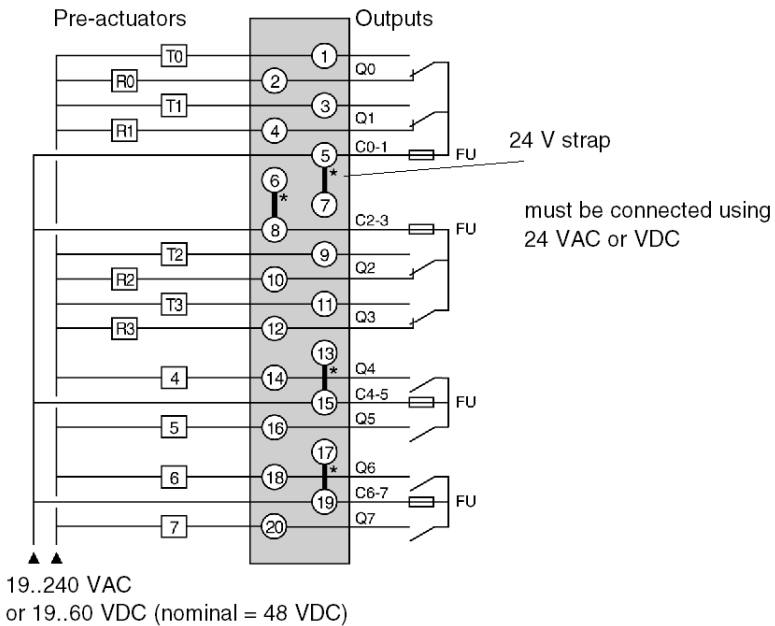

FU 6.3 A quick-blow fuse

TSX DSY 16R5 Discrete output module

23

Overview

This chapter describes the **TSX DSY 16R5** module, its characteristics and its connection to the different pre-actuators.

What's in this Chapter?

This chapter contains the following topics:

Topic	Page
Presentation of the TSX DSY 16R5 module	196
Characteristics of the TSX DSY 16R5 module	197
Connecting the TSX DSY 16R5 module	199

Presentation of the TSX DSY 16R5 module

General

The **TSX DSY 16R5** module

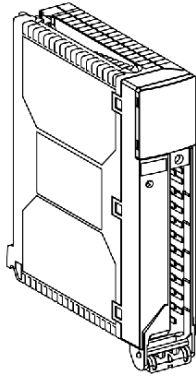

The **TSX DSY 16R5** module is a 16-channel terminal block Discrete relay output module for 3 A thermal current.

The outputs of this module do not feature any contact protection; additional precautions (*see page 175*) must therefore be taken.

Characteristics of the TSX DSY 16R5 module

At a Glance

This section provides a description of the general characteristics of the **TSX DSY 16R5** module.

General characteristics

The following table shows the general characteristics of the **TSX DSY 16R5** module:

The TSX DSY 16R5 module			3 A thermal current relay outputs				
Threshold service voltage <i>(see page 77)</i>	Direct	10..34 VDC					
	Alternating	19..264 VAC					
Thermal current			3 A				
Maximum current per common			3 A (value not to be exceeded)				
Alternating current load	Resistive AC12	Voltage	24 V	48 V	100..120 V	200..240 V	
		Power	50 VA (5)	50 VA (6) 110 VA (4)	110 VA (6) 220 VA (4)	220 VA (6)	
	Inductive AC14 and AC15	Voltage	24 V	48 V	100..120 V	200..240 V	
		Power	24 VA (4)	10 VA (10) 24 VA (8)	10 VA (11) 50 VA (7) 110 VA (2)	10 VA (11) 50 VA (9) 110 VA (6) 220 VA (1)	
	Direct current load	Resistive DC12	Voltage	24 V			
			Power	24 W (6) 40 W (3)			
Inductive DC13 (L/R = 60 ms)		Voltage	24 V				
		Power	10 W (8) 24 W (6)				
Minimum switchable load		1 mA / 5 V					
Response time		Activation	< 8 ms				
	Deactivation	< 10 ms					
Type of contact			normally open				

Built-in protection	against short-circuits and overloads		None, compulsory installation of a quick-blow fuse on every channel or channel group.
	against inductive overloads with alternating current		None, compulsory installation – in parallel to the terminals of each pre-actuator - of a RC circuit or MOV (ZNO) peak limiter, appropriate to the voltage in use.
	against inductive overloads with direct current		None, compulsory installation of a discharge diode at the terminals of each pre-actuator.
Dissipated power (12)			0.25 W + (0.2 x Nb) W
Dielectric strength	Output / ground or Output / internal logic		2000 V actual, 50 / 60 Hz for 1 min
Insulation resistance			> 10 MOhms (below 500 VDC)
Power supply consumption	5 V internal	Typical	80 mA
		Maximum	90 mA
	24 V relay (13)	Typical	8.5 mA
		Maximum	10 mA
Legend:			
(1)	0.1 x 10 ⁶ maneuvers		
(2)	0.15 x 10 ⁶ maneuvers		
(3)	0.3 x 10 ⁶ maneuvers		
(4)	0.5 x 10 ⁶ maneuvers		
(5)	0.7 x 10 ⁶ maneuvers		
(6)	1 x 10 ⁶ maneuvers		
(7)	1.5 x 10 ⁶ maneuvers		
(8)	2 x 10 ⁶ maneuvers		
(9)	3 x 10 ⁶ maneuvers		
(10)	5 x 10 ⁶ maneuvers		
(11)	10 x 10 ⁶ maneuvers		
(12)	Nb = number of outputs at 1.		
(13)	Per channel at 1		

Connecting the TSX DSY 16R5 module

At a Glance

The **TSX DSY 16R5** module comprises 16 relay output channels for 3 A thermal current.

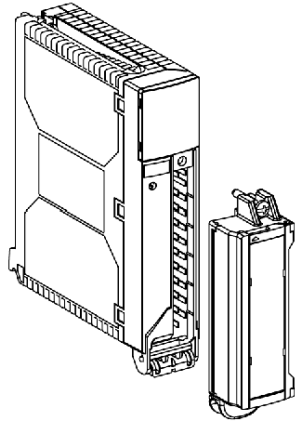

This module is equipped with a removable 20 post screwed connection terminal block, allowing outputs to be connected:

Circuit Diagram

The circuit diagram for an output is shown below.

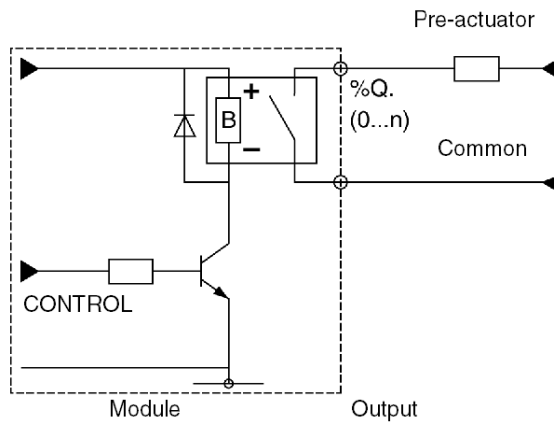

Module connection

The diagram below shows the connection of the module to the pre-actuators.

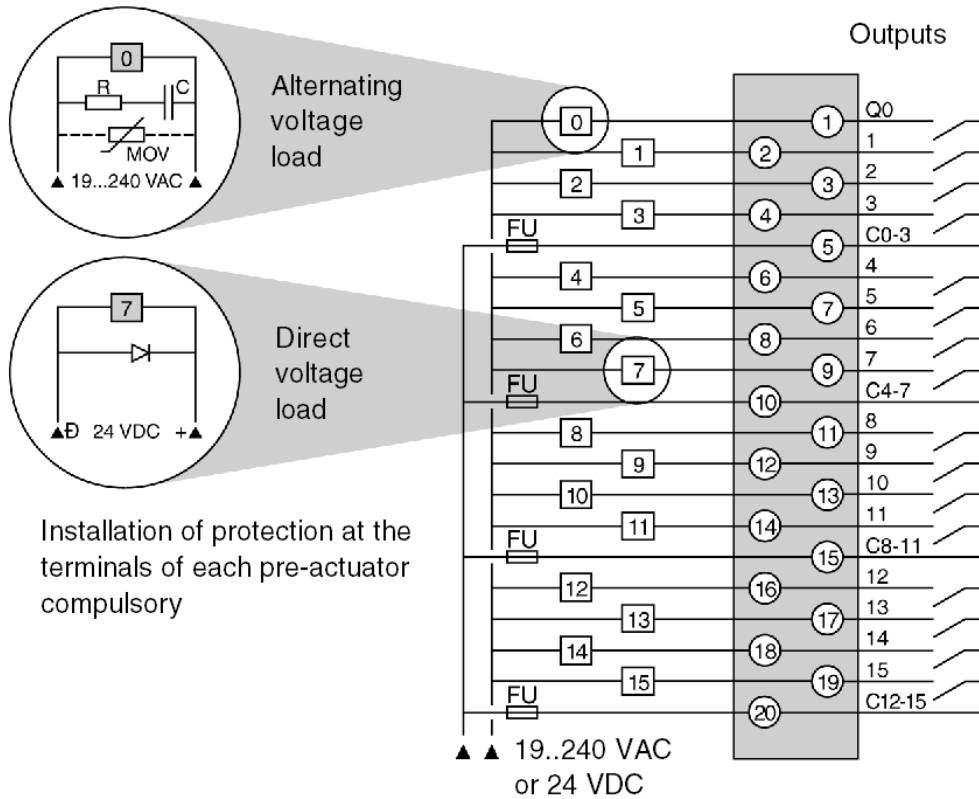

Installation of protection at the terminals of each pre-actuator compulsory

Precaution

NOTE: In the event of pre-actuator supply voltage being obtained from a tri-phase network which is equal to or greater than 200 VAC, the pre-actuators must be supplied from the same phase.

TSX DSY 08S5 Discrete output module

24

Overview

This chapter describes the **TSX DSY 08S5** module, its characteristics and its connection to the different pre-actuators.

What's in this Chapter?

This chapter contains the following topics:

Topic	Page
Presentation of the TSX DSY 08S5 module	202
Characteristics of the TSX DSY 08S5 module	203
Connecting the TSX DSY 08S5 module	204

Presentation of the TSX DSY 08S5 module

General

The **TSX DSY 08S5** module

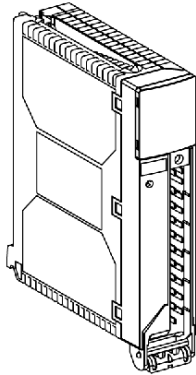

The **TSX DSY 08S5** module is a 8-channel terminal block Discrete bidirectional triode thyristor output module.

This module features protection of contacts by interchangeable fuses
(*see page 183*).

Characteristics of the TSX DSY 08S5 module

At a Glance

This section provides a description of the general characteristics of the **TSX DSY 08S5** module.

General characteristics

The following table shows the general characteristics of the **TSX DSY 08S5** module:

The TSX DSY 08S5 module		Bidirectional triode thyristor outputs
Threshold service voltage	Direct	prohibited
	Alternating	41..264 V
Admissible current <i>(see page 77)</i>	channel	2 A
	module	12 A
Leakage current		≤ 2 mA
Response time	Activation	≤ 10 ms
	Deactivation	≤ 10 ms
Built-in protection	against over-voltage	R-C and Ge-Mov circuit
	against short-circuits and overloads	interchangeable quick-blow fuse per common - 5 A
Dissipated power		0.5 W + 1 W per A and per output
Dielectric strength	Output / ground or Output / internal logic	2000 V actual, 50 / 60 Hz for 1 min
Insulation resistance		> 10 MOhms (below 500 VDC)
5 V supply consumption	Typical	125 mA
	Maximum	135 mA

Connecting the TSX DSY 08S5 module

At a Glance

The **TSX DSY 08S5** module comprises 8 bidirectional triode thyristor output channels.

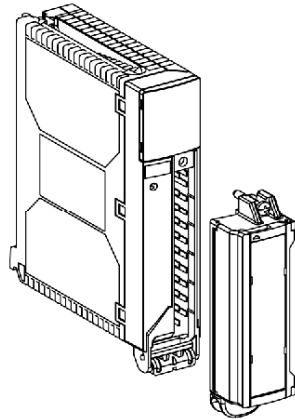

This module is equipped with a removable 20 post screwed connection terminal block, allowing outputs to be connected:

Circuit Diagram

The circuit diagram for an output is shown below.

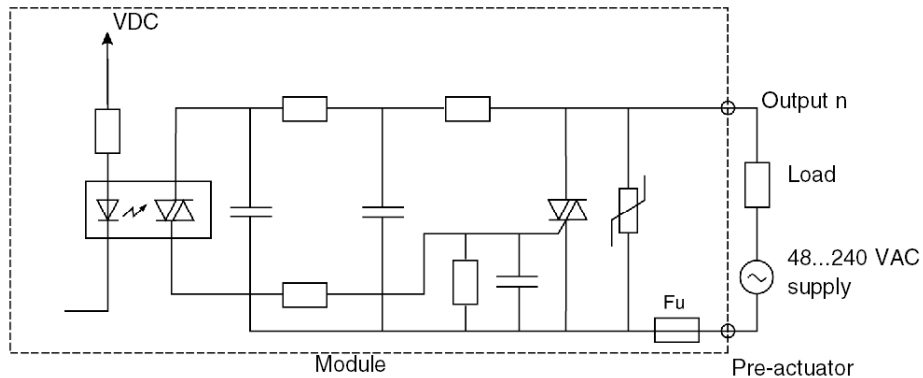

Module connection

The diagram below shows the connection of the module to the pre-actuators.

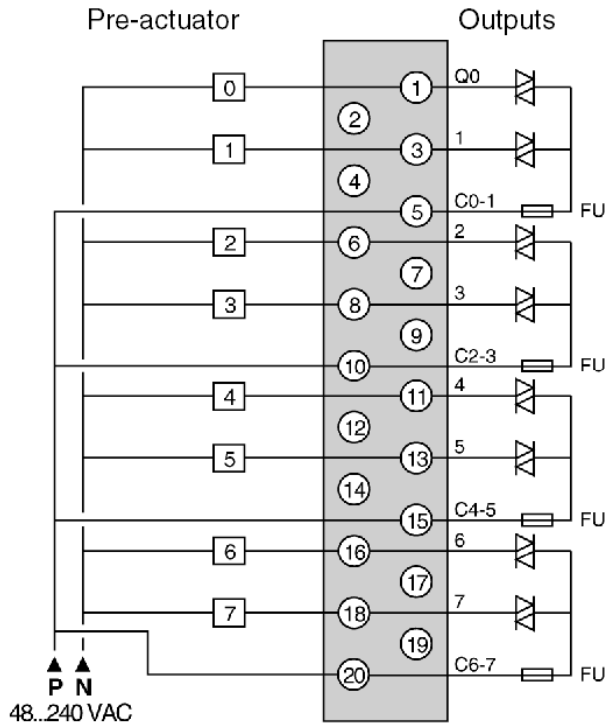

FU Ultra-quick blow interchangeable 5 A fuse

TSX DSY 16S5 Discrete output module

25

Overview

This chapter describes the **TSX DSY 16S5** module, its characteristics and its connection to the different pre-actuators.

What's in this Chapter?

This chapter contains the following topics:

Topic	Page
Presentation of the TSX DSY 16S5 module	208
Characteristics of the TSX DSY 16S5 module	209
Connecting the TSX DSY 16S5 module	210

Presentation of the TSX DSY 16S5 module

General

The **TSX DSY 16S5** module

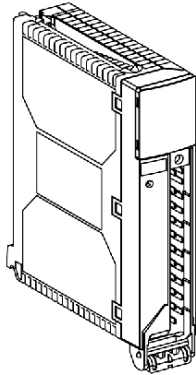

The **TSX DSY 16S5** module is a 16-channel terminal block Discrete bidirectional triode thyristor output module.

This module features protection of contacts by interchangeable fuses
(*see page 183*).

Characteristics of the TSX DSY 16S5 module

At a Glance

This section provides a description of the general characteristics of the **TSX DSY 16S5** module.

General characteristics

The following table shows the general characteristics of the **TSX DSY 16S5** module:

The TSX DSY 16S5 module		Bidirectional triode thyristor outputs
Threshold service voltage	Direct	prohibited
	Alternating	41..264 V
Admissible current <i>(see page 77)</i>	channel	1 A
	module	12 A
Leakage current		≤ 2 mA
Response time	Activation	≤ 10 ms
	Deactivation	≤ 10 ms
Built-in protection	against over-voltage	R-C and Ge-Mov circuit
	against short-circuits and overloads	interchangeable quick-blow fuse per common - 5 A
Dissipated power		0.85 W + 1 W per A and per output
Dielectric strength	Output / ground or Output / internal logic	2000 V actual, 50 / 60 Hz for 1 min
Insulation resistance		> 10 MOhms (below 500 VDC)
5 V supply consumption	Typical	220 mA
	Maximum	230 mA

Connecting the TSX DSY 16S5 module

At a Glance

The **TSX DSY 16S5** module comprises 16 bidirectional triode thyristor output channels.

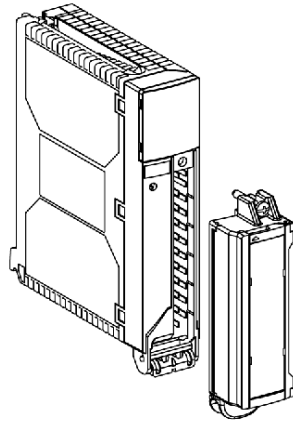

This module is equipped with a removable 20 post screwed connection terminal block, allowing outputs to be connected:

Circuit Diagram

The circuit diagram for an output is shown below.

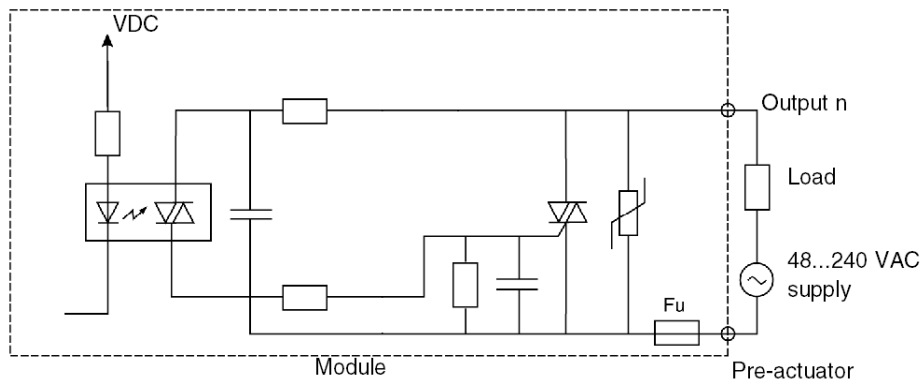

Module connection

The diagram below shows the connection of the module to the pre-actuators.

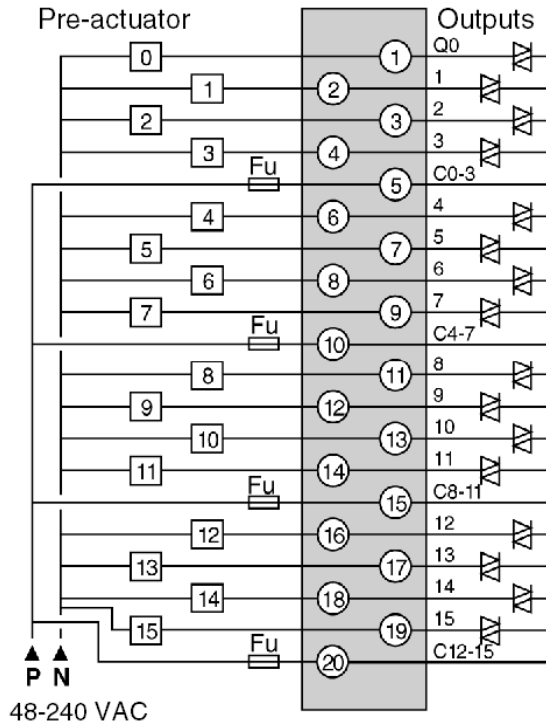

FU Ultra-quick blow interchangeable 5 A fuse

TSX DSY 16S4 Discrete output module

26

Overview

This chapter describes the **TSX DSY 16S4** module, its characteristics and its connection to the different pre-actuators.

What's in this Chapter?

This chapter contains the following topics:

Topic	Page
Presentation of the TSX DSY 16S4 module	214
Characteristics of the TSX DSY 16S4 module	215
Connecting the TSX DSY 16S4 module	216

Presentation of the TSX DSY 16S4 module

General

The **TSX DSY 16S4** module

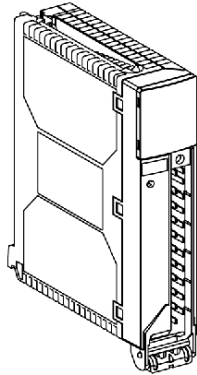

The **TSX DSY 16S4** module is a 16-channel terminal block Discrete bidirectional triode thyristor output module.

Characteristics of the TSX DSY 16S4 module

At a Glance

This section provides a description of the general characteristics of the **TSX DSY 16S4** module.

General characteristics

The following table shows the general characteristics of the **TSX DSY 16S4** module:

The TSX DSY 16S4 module		Bidirectional triode thyristor outputs
Threshold service voltage	Direct	prohibited
	Alternating	20..132 V
Admissible current <i>(see page 77)</i>	channel	1 A
	module	12 A
Leakage current		≤1.5 mA
Response time	Activation	≤10 ms
	Deactivation	≤10 ms
Built-in protection	against over-voltage	R-C and Ge-Mov circuit
	against short-circuits and overloads	10 A non-interchangeable fireproof protection per common
Dissipated power		0.5 W + 1 W per A and per output
Dielectric strength	Output / ground or Output / internal logic	2000 V actual, 50 / 60 Hz for 1 min
Insulation resistance		> 10 MOhms (below 500 VDC)
5 V supply consumption	Typical	220 mA
	Maximum	230 mA

Connecting the TSX DSY 16S4 module

At a Glance

The **TSX DSY 16S4** module comprises 16 bidirectional triode thyristor output channels.

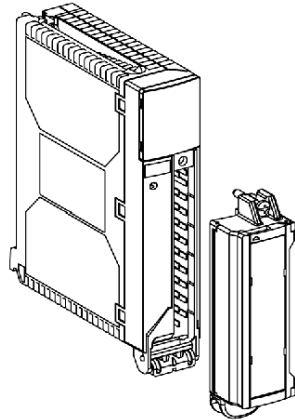

This module is equipped with a removable 20 post screwed connection terminal block, allowing outputs to be connected:

Circuit Diagram

The circuit diagram for an output is shown below.

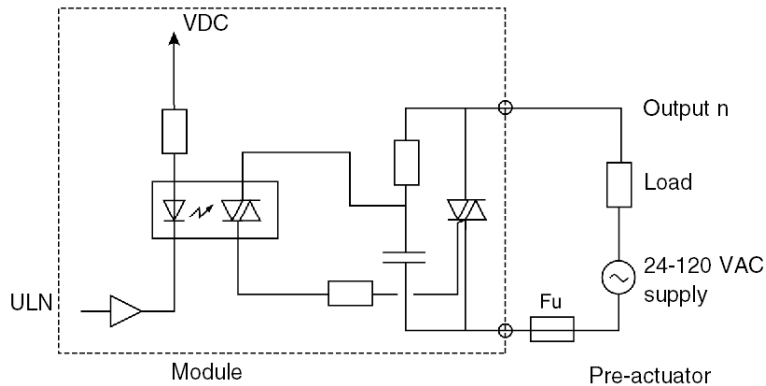

Module connection

The diagram below shows the connection of the module to the pre-actuators.

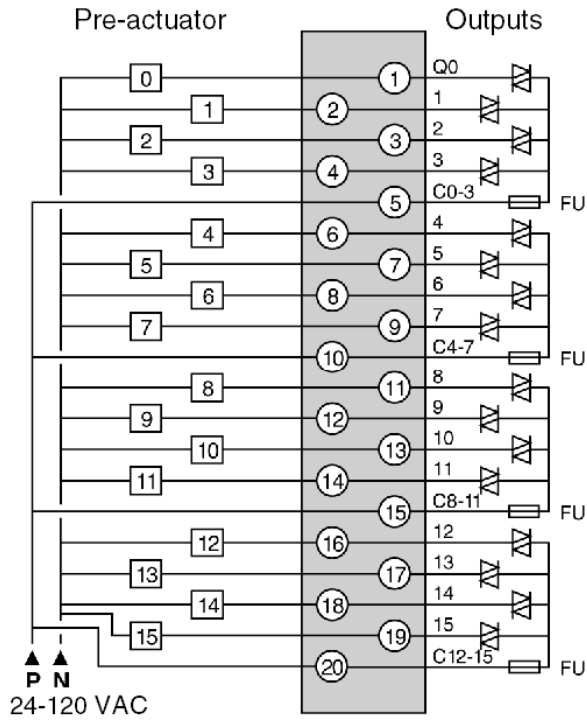

FU Ultra-quick blow interchangeable 5 A fuse

TSX DSY 32T2K Discrete output module

27

Overview

This chapter describes the **TSX DSY 32T2K** module, its characteristics and its connection to the different pre-actuators.

What's in this Chapter?

This chapter contains the following topics:

Topic	Page
Presentation of the TSX DSY 32T2K module	220
Characteristics of the TSX DSY 32T2K module	221
Connecting the TSX DSY 32T2K module	223

Presentation of the TSX DSY 32T2K module

General

The **TSX DSY 32T2K** module

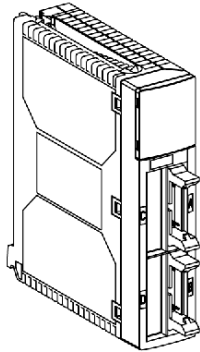

The **TSX DSY 32T2K** module is a 32-channel connector Discrete transistor output module for direct current.

Characteristics of the TSX DSY 32T2K module

At a Glance

This section provides a description of the general characteristics of the **TSX DSY 32T2K** module.

General characteristics

The following table shows the general characteristics of the **TSX DSY 32T2K** module:

TSX DSY 32T2K module		24 VDC positive logic transistor outputs
Nominal values	Voltage	24 VDC
	Current	0.1 A
Threshold values (1)	Voltage (including ripple)	19..30 V (34 V possible for 1 hour every 24 hours))
	Current/channel	0.125 A
	Current/module	3.2 A
Power of tungsten filament lamp	Maximum	1.2 W
Leakage current	at 0	< 0.1 mA (for U = 30 V)
Voltage drop	at 1	< 1.5 V (for I = 0.1 A)
Load impedance	minimum	220 Ohms
Response time (2)		1.2 ms
Frequency of switching to inductive load		0.5 / LI ² Hz
Paralleling of outputs		Yes (maximum of 3)
Compatibility with IEC 1131-2 DC inputs		Yes (type 1 and type 2)
Built-in protection	against over-voltage	Yes, by Transil diode
	against inversions	Yes, by inverted diode (3)
	against short-circuits and overloads	Yes, by current limiter and electric circuit-breaker 0.125 A < I _d < 0.185 A
Pre-actuator voltage check threshold	OK	> 18 V
	Error	< 14 V
Check response time	on appearance	T < 4 ms
	on disappearance	T < 30 ms
5 V consumption	typical	135 mA
	maximum	155 mA
24 V pre-actuator consumption (4)	typical	30 mA
	maximum	40 mA

Dissipated power (5)		1.6 W + (0.1 x Nb) W
Dielectric strength	Output / ground or	1500 V actual, 50 / 60 Hz for 1 min
	Output / internal logic	
Insulation resistance		> 10 MOhms (below 500 VDC)
Temperature downgrading (see page 77)		The characteristics at 60° C are guaranteed for 60 % of max. module current
Legend:		
(1)	For U ≤30 V or 34 V.	
(2)	All the outputs are equipped with fast electromagnet demagnetization circuits. Electromagnet discharge time < L/R	
(3)	Fit a 2 A fuse to the +24 V pre-actuator supply (1 per connector).	
(4)	Excluding load current.	
(5)	Nb = number of outputs at 1.	

Connecting the TSX DSY 32T2K module

At a Glance

The **TSX DSY 32T2K** module comprises 32 positive logic transistor output channels for direct current.

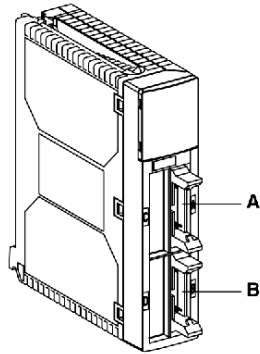

This module is fitted with 2 male **HE10** connectors:

- connector A for outputs 0 to 15;
- connector B for outputs 16 to 31.

Circuit diagram

The circuit diagram for an output is shown below.

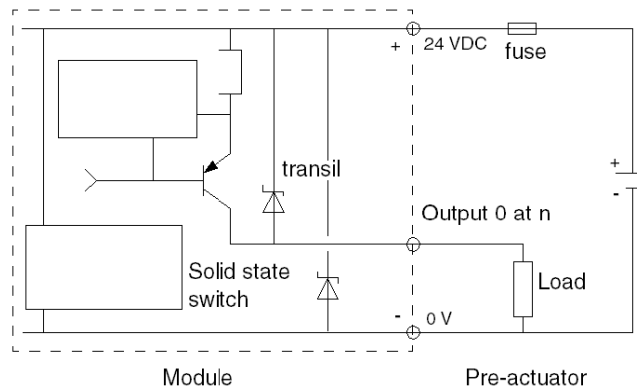

Module connection

The diagram below shows the connection of the module to the pre-actuators.

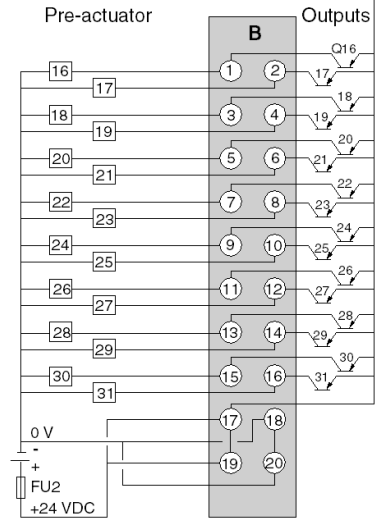
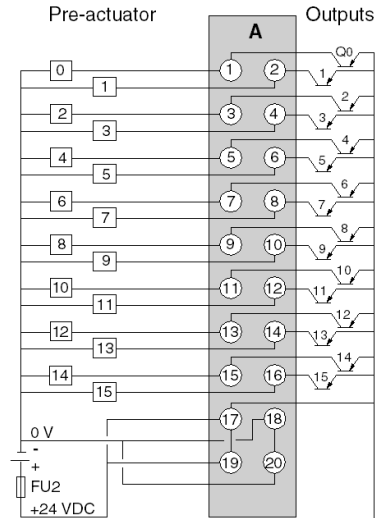

FU2 2 A quick-blow fuse.

NOTE: It is compulsory to connect:

- the + 24 VDC to terminals 17 and 19;
- the 0 V to terminals 18 and 20.

TSX DSY 64T2K Discrete output module

28

Overview

This chapter describes the **TSX DSY 64T2K** module, its characteristics and its connection to the different pre-actuators.

What's in this Chapter?

This chapter contains the following topics:

Topic	Page
Presentation of the TSX DSY 64T2K module	226
Characteristics of the TSX DSY 64T2K module	227
Connecting the TSX DSY 64T2K module	229

Presentation of the TSX DSY 64T2K module

General

The **TSX DSY 64T2K** module

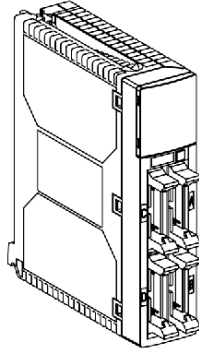

The **TSX DSY 64T2K** module is a 64-channel connector Discrete transistor output module for direct current.

Characteristics of the TSX DSY 64T2K module

At a Glance

This section provides a description of the general characteristics of the **TSX DSY 64T2K** module.

General characteristics

The following table shows the general characteristics of the **TSX DSY 64T2K** module:

The TSX DSY 64T2K module		24 VDC positive logic transistor outputs
Nominal values	Voltage	24 VDC
	Current	0.1 A
Threshold values (1)	Voltage (including ripple)	19..30 V (34 V possible for 1 hour every 24 hours)
	Current/channel	0.125 A
	Current/module	5 A
Power of tungsten filament lamp	Maximum	1.2 W
Leakage current	at 0	< 0.1 mA (for U = 30 V)
Voltage drop	at 1	< 1.5 V (for I = 0.1 A)
Load impedance	minimum	220 Ohms
Response time (2)		1.2 ms
Frequency of switching to inductive load		0.5 / LI ² Hz
Paralleling of outputs		Yes (maximum of 3)
Compatibility with IEC 1131-2 DC inputs		Yes (type 1 and type 2)
Built-in protection	against over-voltage	Yes, by Transil diode
	against inversions	Yes, by inverted diode (3)
	against short-circuits and overloads	Yes, by current limiter and electric circuit-breaker 0.125 A < Id < 0.185 A
Pre-actuator voltage check threshold	OK	> 18 V
	Error	< 14 V
Check response time	on appearance	T < 4 ms
	on disappearance	T < 30 ms
5 V consumption	typical	135 mA
	maximum	175 mA
24 V pre-actuator consumption (4)	typical	60 mA
	maximum	80 mA

Dissipated power (5)		2.4 W + (0.1 x Nb) W
Dielectric strength	Output / ground or Output / internal logic	1500 V actual, 50 / 60 Hz for 1 min
Insulation resistance		> 10 MOhms (below 500 VDC)
Temperature downgrading (see page 77)		The characteristics at 60 °C are guaranteed for 60 % of max. module current
Legend:		
(1)	For U ≤30 V or 34 V.	
(2)	All the outputs are equipped with fast electromagnet demagnetization circuits. Electromagnet discharge time < L/R	
(3)	Fit a 2 A fuse to the +24 V pre-actuator supply (1 per connector).	
(4)	Excluding load current.	
(5)	Nb = number of outputs at 1.	

Connecting the TSX DSY 64T2K module

At a Glance

The **TSX DSY 64T2K** module comprises 64 positive logic transistor output channels for direct current.

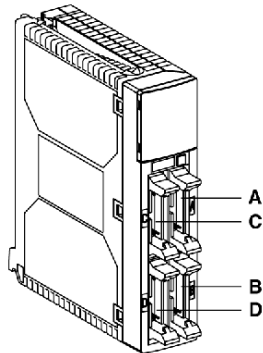

This module is fitted with 4 male **HE10** connectors:

- connector A for outputs 0 to 15;
- connector B for outputs 16 to 31;
- connector C for outputs 32 to 47;
- connector D for outputs 48 to 63.

Circuit diagram

The circuit diagram for an output is shown below.

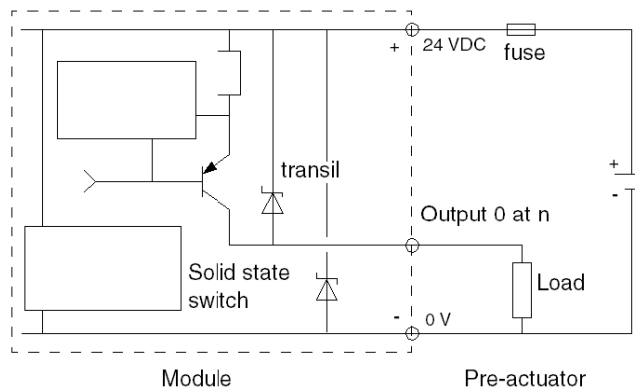

Module connection

The diagram below shows the connection of the module to the pre-actuators.

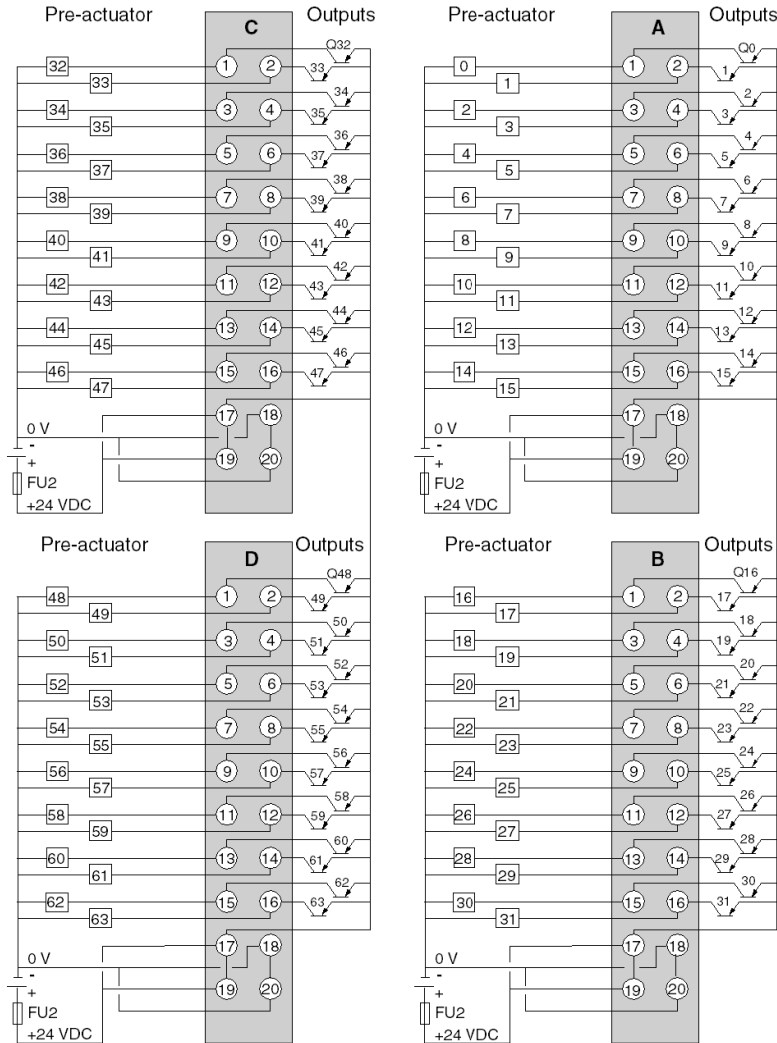

FU2 2 A quick-blow fuse.

NOTE: It is compulsory to connect:

- the + 24 VDC to terminals 17 and 19;
- the 0 V to terminals 18 and 20.

TSX DMY 28FK Discrete mixed I/O module

29

Overview

This chapter describes the **TSX DMY 28FK** module, its characteristics and its connection to the different sensors and pre-actuators.

What's in this Chapter?

This chapter contains the following topics:

Topic	Page
Presentation of the TSX DMY 28FK module	232
Characteristics of the TSX DMY 28FK module	233
Connecting the TSX DMY 28FK module	236

Presentation of the TSX DMY 28FK module

General

The **TSX DMY 28FK** module

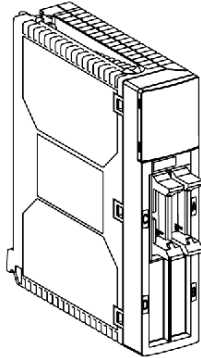

The **TSX DMY 28FK** is a Discrete mixed I/O module with both 16 x 24 VDC fast input connector channels and 12 x 24 VDC transistor output channels.

This module's inputs have the following specific functions:

- programmable filtering: inputs are equipped with a filtering system which is programmable for each channel (*see page 117*),
- latching: allows particularly short pulses with a duration lower than the PLC cycle time (*see page 118*) to be taken into account,
- event inputs: allows events to be taken into account and processed immediately (*see page 120*).

Characteristics of the TSX DMY 28FK module

At a Glance

This section provides a description of the general characteristics of the **TSX DMY 28FK** mixed module.

General characteristics

The following table shows the general characteristics of the **TSX DMY 28FK** module inputs:

The TSX DMY 28FK module		24 VDC positive logic inputs	
Nominal input values		Voltage	24 VDC
		Current	3.5 mA
Threshold input values	at 1	Voltage	≥ 11 V
		Current	≥ 3 mA
	at 0	Voltage	≤ 5 V
		Current	≤ 1.5 mA
	Sensor supply (including ripple)		19..30 V (possibly up to 34 V, limited to 1 hour every 24 hours)
	Input impedance	at nominal U	6.3 kOhms
Response time	by default	4 ms	
	configurable filtering	0.1..7.5 ms (in 0.5 ms steps)	
IEC 1131-2 compliance		type 1	
2 wire / 3 wire proximity sensor compatibility (see page 50)		IEC 947-5-2	
Dielectric strength	Input / ground or Input / internal logic	1500 V actual, 50 / 60 Hz for 1 min	
Insulation resistance		> 10 MOhms (below 500 VDC)	
Type of input		current sink	
Paralleling of inputs (1)		yes	
Sensor voltage check threshold	OK	> 18 V	
	Error	< 14 V	
Check response time	on appearance	8 ms < T < 30 ms	
	on disappearance	1 ms < T < 3 ms	
5 V consumption	typical	300 mA	
	maximum	350 mA	
Sensor supply consumption (2)	typical	20 mA + (3.5 x Nb) mA	
	maximum	30 mA + (3.5 x Nb) mA	

Dissipated power (2)	1.2 W + (0.1 x Nb) W
Temperature downgrading (see page 77)	The characteristics at 60° are guaranteed for 60 % of inputs set to 1
Legend:	
(1)	This characteristic is used to connect several inputs to the same module in parallel, or to different modules for input redundancy.
(2)	Nb = number of channels at 1.

General characteristics

The following table shows the general characteristics of the **TSX DMY 28FK** module outputs:

The TSX DMY 28FK module		24 VDC positive logic transistor outputs
Nominal values	Voltage	24 VDC
	Current	0.5 A
Threshold values (1)	Voltage (including ripple)	19..30 V (34 V possible for 1 hour every 24 hours)
	Current/channel	0.625 A
	Current/module	4 A
Power of tungsten filament lamp	Maximum	6 W
Leakage current	at 0	< 1 mA
Voltage drop	at 1	< 1.2 V
Load impedance	minimum	48 Ohms
Response time (2)		0.6 ms
Frequency of switching to inductive load		0.5 / LI ² Hz
Paralleling of outputs		Yes (maximum of 2)
Compatibility with IEC 1131-2 DC inputs		Yes (type 1 and type 2)
Built-in protection	against over-voltage	Yes, by Transil diode
	against inversions	Yes, by inverted diode (3)
	against short-circuits and overloads	Yes, by current limiter and electric circuit-breaker 1.5 In < Id < 2 In
Pre-actuator voltage check threshold	OK	> 18 V
	Error	< 14 V
Check response time	on appearance	T < 4 ms
	on disappearance	T < 30 ms

24 V pre-actuator consumption (4)	typical	30 mA
	maximum	40 mA
Dissipated power (5)		2.4 W + (0.75 x Nb) W
Dielectric strength	Output / ground or Output / internal logic	1500 V actual, 50 / 60 Hz for 1 min
Insulation resistance		> 10 MOhms (below 500 VDC)
Temperature downgrading (see page 77)		The characteristics at 60 °C are guaranteed for 60 % of max. module current
Legend:		
(1)	For $U \leq 30$ V or 34 V.	
(2)	All the outputs are equipped with fast electromagnet demagnetization circuits. Electromagnet discharge time < L/R	
(3)	Fit a fuse to the +24 V pre-actuator supply.	
(4)	Excluding load current.	
(5)	Nb = number of outputs at 1.	

Connecting the TSX DMY 28FK module

At a Glance

The **TSX DMY 28FK** mixed I/O module comprises 16 x 24 VDC fast input channels and 12 x 24 VDC/ 0.5A output channels.

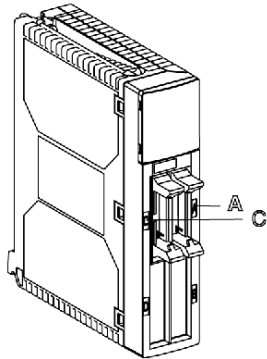

This module is fitted with 2 male **HE10** connectors:

- Connector A reserved for inputs (addresses 0 to 15);
- Connector C reserved for outputs (addresses 16 to 27).

Circuit Diagram

The circuit diagram for an input is shown below.

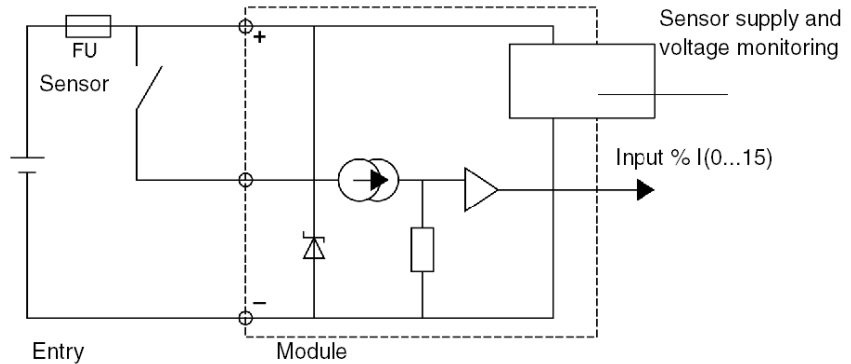

Circuit Diagram

The circuit diagram for an output is shown below.

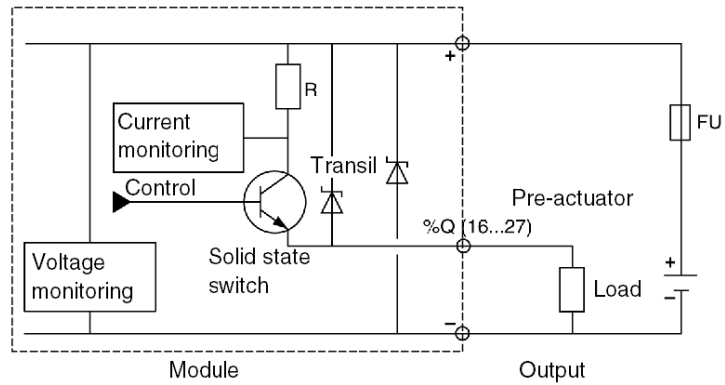

Module connection

The following diagram shows the connection of the module to the sensors.

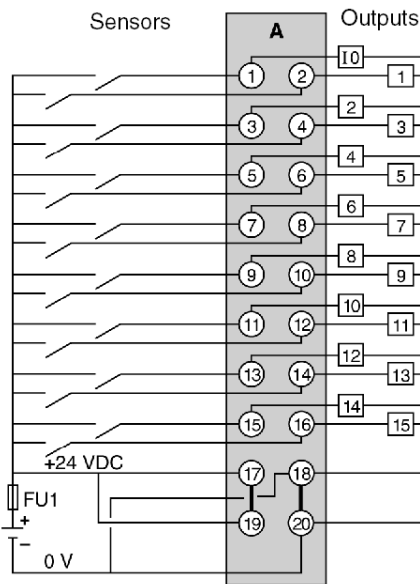

FU1 0.5 A quick-blow fuse.

Module connection

The diagram below shows the connection of the module to the pre-actuators.

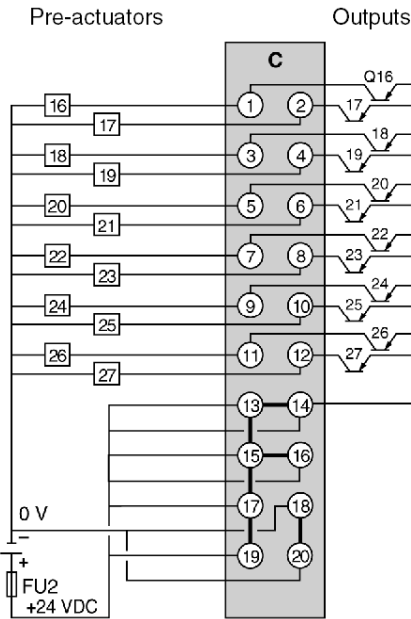

FU2 10 A quick-blow fuse.

TSX DMY 28RFK Discrete mixed I/O module

30

Overview

This chapter describes the **TSX DMY 28RFK** module, its characteristics and its connection to the different sensors and pre-actuators.

What's in this Chapter?

This chapter contains the following topics:

Topic	Page
Presentation of the TSX DMY 28RFK module	240
Specific functions of the TSX DMY 28RFK module: reflex and timing	241
Characteristics of the TSX DMY 28RFK module	242
Connecting the TSX DMY 28RFK module	245

Presentation of the TSX DMY 28RFK module

General

The **TSX DMY 28RFK** module

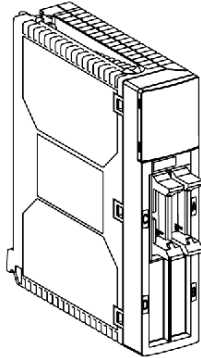

The **TSX DMY 28RFK** is a Discrete mixed I/O module with both 16 x 24 VDC fast input connector channels and 12 x 24 VDC transistor output channels.

This module's inputs have the following specific functions:

- programmable filtering: inputs are equipped with a filtering system which is programmable for each channel (*see page 117*),
- reflex and timing: for applications requiring a faster response time than the FAST task or event processing (< 500 micros) (*see page 241*).

Specific functions of the TSX DMY 28RFK module: reflex and timing

At a Glance

The reflex and timing functions of the **TSX DMY 28RFK** module allow it to be used for applications requiring a faster response time than that of the **FAST** task or event processing (< 500 micros).

Description

Reflex and timing functions allow those PLC functions that are executed on the module and disconnected from the PLC task to be performed, by using the following as input variables:

- physical module inputs,
- module output commands,
- module or channel error data,
- physical module output statuses.

These functions are programmed using the Unity Proware (*see page 463*).

Characteristics of the TSX DMY 28RFK module

At a Glance

This section provides a description of the general characteristics of the **TSX DMY 28RFK** mixed module.

General characteristics

The following table shows the general characteristics of the **TSX DMY 28RFK** module inputs:

The TSX DMY 28RFK module		24 VDC positive logic inputs	
Nominal input values		Voltage	24 VDC
		Current	3.5 mA
Threshold input values	at 1	Voltage	≥ 11 V
		Current	≥ 3 mA
	at 0	Voltage	≤ 5 V
		Current	≤ 1.5 mA
Sensor supply (including ripple)		19..30 V (possibly up to 34 V, limited to 1 hour every 24 hours)	
Input impedance	at nominal U	6.3 kOhms	
Response time	by default	4 ms	
	configurable filtering	0.1..7.5 ms (in 0.5 ms steps)	
IEC 1131-2 compliance		type 1	
2 wire / 3 wire proximity sensor compatibility (see page 50)		IEC 947-5-2	
Dielectric strength	Input / ground or Input / internal logic	1500 V actual, 50 / 60 Hz for 1 min	
Insulation resistance		> 10 MOhms (below 500 VDC)	
Type of input		current sink	
Paralleling of inputs (1)		yes	
Sensor voltage check threshold	OK	> 18 V	
	Error	< 14 V	
Check response time	on appearance	8 ms < T < 30 ms	
	on disappearance	1 ms < T < 3 ms	
5 V consumption	typical	300 mA	
	maximum	350 mA	
Sensor supply consumption (2)	typical	20 mA + (3.5 x Nb) mA	
	maximum	30 mA + (3.5 x Nb) mA	

Dissipated power (2)	1.2 W + (0.1 x Nb) W
Temperature downgrading (see page 77)	The characteristics at 60° are guaranteed for 60 % of inputs set to 1
Legend:	
(1)	This characteristic is used to connect several inputs to the same module in parallel, or to different modules for input redundancy.
(2)	Nb = number of channels at 1.

General characteristics

The following table shows the general characteristics of the **TSX DMY 28RFK** module outputs:

The TSX DMY 28RFK module		24 VDC positive logic transistor outputs
Nominal values	Voltage	24 VDC
	Current	0.5 A
Threshold values (1)	Voltage (including ripple)	19..30 V (34 V possible for 1 hour every 24 hours)
	Current/channel	0.625 A
	Current/module	4 A
Power of tungsten filament lamp	Maximum	6 W
Leakage current	at 0	< 1 mA
Voltage drop	at 1	< 1.2 V
Load impedance	minimum	48 Ohms
Response time (2)		0.6 ms
Frequency of switching to inductive load		0.5 / L I ² Hz
Paralleling of outputs		Yes (maximum of 2)
Compatibility with IEC 1131-2 DC inputs		Yes (type 1 and type 2)
Built-in protection	against over-voltage	Yes, by Transil diode
	against inversions	Yes, by inverted diode (3)
	against short-circuits and overloads	Yes, by current limiter and electric circuit-breaker 1.5 I _n < I _d < 2 I _n
Pre-actuator voltage check threshold	OK	> 18 V
	Error	< 14 V
Check response time	on appearance	T < 4 ms
	on disappearance	T < 30 ms

24 V pre-actuator consumption (4)	typical	40 mA
	maximum	60 mA
Dissipated power (5)		2.4 W + (0.75 x Nb) W
Dielectric strength	Output / ground or Output / internal logic	1500 V actual, 50 / 60 Hz for 1 min
Insulation resistance		> 10 MOhms (below 500 VDC)
Temperature downgrading (see page 77)		The characteristics at 60 °C are guaranteed for 60 % of max. module current
Legend:		
(1)	For U ≤30 V or 34 V.	
(2)	All the outputs are equipped with fast electromagnet demagnetization circuits. Electromagnet discharge time < L/R	
(3)	Fit a fuse to the +24 V pre-actuator supply.	
(4)	Excluding load current.	
(5)	Nb = number of outputs at 1.	

Connecting the TSX DMY 28RFK module

At a Glance

The **TSX DMY 28RFK** mixed I/O module comprises 16 x 24 VDC fast input channels and 12 x 24 VDC / 0.5 A output channels.

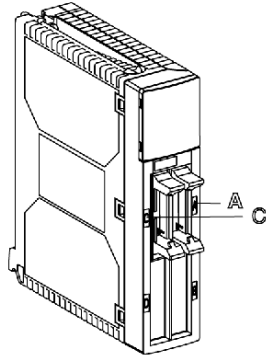

This module is fitted with 2 male **HE10** connectors:

- Connector A reserved for inputs (addresses 0 to 15);
- Connector C reserved for outputs (addresses 16 to 27).

Circuit Diagram

The circuit diagram for an input is shown below.

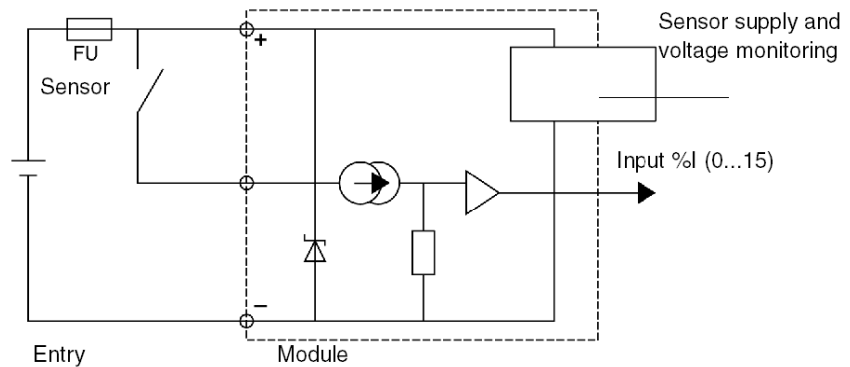

Circuit Diagram

The circuit diagram for an output is shown below.

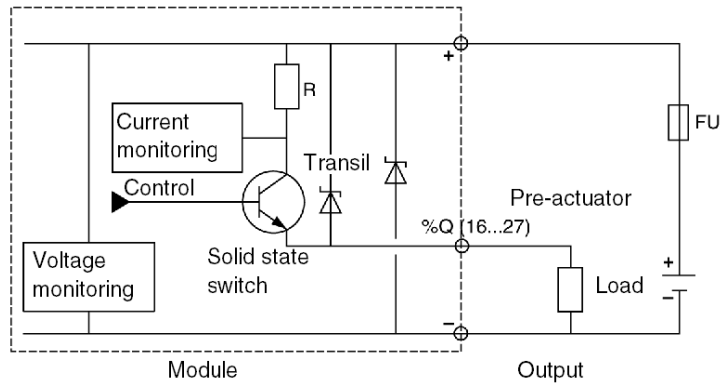

Module connection

The following diagram shows the connection of the module to the sensors.

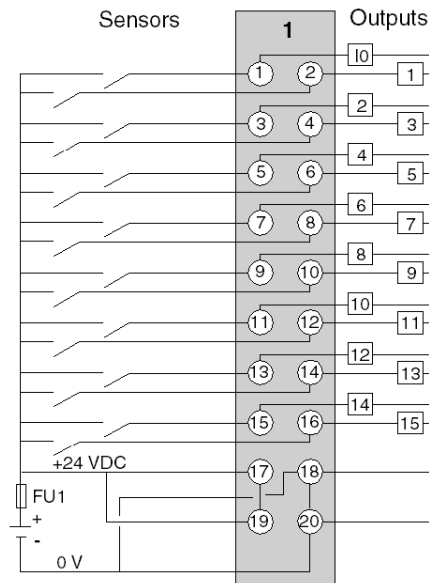

FU1 0.5 A quick-blow fuse.

Module connection

The diagram below shows the connection of the module to the pre-actuators.

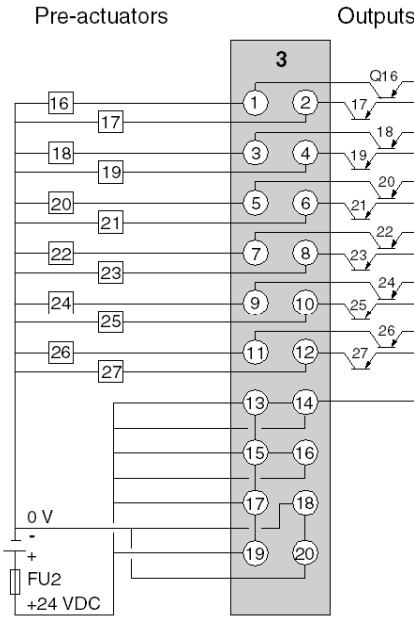

FU2 10 A quick-blow fuse.

TELEFAST 2 Connection Interface Links for the Discrete I/O Modules

31

Aim of this Chapter

This chapter describes the TELEFAST 2 interface links for the discrete input/output modules.

What's in this Chapter?

This chapter contains the following sections:

Section	Topic	Page
31.1	Introduction to the TELEFAST 2 Connection Interfaces for Discrete I/O	251
31.2	Connection Principles for the TELEFAST 2 Interfaces for Discrete I/O	261
31.3	TELEFAST 2 ABE-7H08R10/08R11 and ABE-7H16R10/16R11 Connection Bases	266
31.4	TELEFAST 2 ABE-7H12R10/12R11 Connection Bases	268
31.5	TELEFAST 2 ABE-7H08R21 and ABE-7H16R20/16R21/16R23 Connection Bases	270
31.6	TELEFAST 2 ABE-7H12R20/12R21 Connection Bases	272
31.7	TELEFAST 2 ABE-7H08S21/16S21 Connection Bases	274
31.8	TELEFAST 2 ABE-7H12S21 Connection Base	276
31.9	TELEFAST 2 ABE-7H16R30/16R31 Connection Bases	278
31.10	TELEFAST 2 ABE-7H12R50 Connection Base	280
31.11	TELEFAST 2 ABE-7H16R50 Connection Base	282
31.12	TELEFAST 2 ABE-7H16F43 Connection Base	284
31.13	TELEFAST 2 ABE-7H16S43 Connection Base	285
31.14	TELEFAST 2 ABE-7R08S111/16S111 connection bases	286
31.15	TELEFAST 2 ABE-7R08S210/16S210 connection bases	291
31.16	TELEFAST 2 ABE-7R16S212 connection base	296
31.17	Connection bases TELEFAST 2 ABE-7S16E2B1/E2E1/E2E0/E2F0/E2M0	300
31.18	TELEFAST 2 ABE-7S16S2BO/S2B2 connection bases	303
31.19	TELEFAST 2 ABE-7S08S2B1connection base	306
31.20	TELEFAST 2 ABE-7S08S2B0 connection base	309

Section	Topic	Page
31.21	TELEFAST 2 ABE-7R16T210/P16T210 connection bases	312
31.22	TELEFAST 2 ABE-7R16T212/P16T212 connection bases	314
31.23	TELEFAST 2 ABE-7R16T230 connection base	316
31.24	TELEFAST 2 ABE-7R16T231 connection base	317
31.25	TELEFAST 2 ABE-7P16T214 connection base	319
31.26	TELEFAST 2 ABE-7P16T215 connection base	321
31.27	TELEFAST 2 ABE-7R16T330/P16T330 connection bases	323
31.28	TELEFAST 2 ABE-7R16T332/P16T332 connection bases	325
31.29	TELEFAST 2 ABE-7R16T370 connection base	327
31.30	TELEFAST 2 ABE-7P16T334 connection base	329
31.31	TELEFAST 2 ABE-7P16T318 connection base	331
31.32	TELEFAST 2 ABE-7P16F310 connection base	333
31.33	TELEFAST 2 ABE-7P16F312 connection base	334
31.34	TELEFAST 2 Connection Base Accessories	335

31.1 Introduction to the TELEFAST 2 Connection Interfaces for Discrete I/O

Aim of this section

This section describes the range of **TELEFAST 2** products which allow the discrete input and output modules to be connected quickly to the operating pieces.

What's in this Section?

This section contains the following topics:

Topic	Page
General Overview of TELEFAST 2 Connection Interfaces for Discrete I/O Modules	252
TELEFAST 2 Connection Bases Catalog	253
Combination of Premium I/O modules and TELEFAST 2 connection bases	259

General Overview of TELEFAST 2 Connection Interfaces for Discrete I/O Modules

At a Glance

The TELEFAST 2 system is a group of products which enableS discrete input and output modules to be quickly connected to operational components. It replaces 20-pin terminal blocks, thus doing away with single wire connections.

The TELEFAST 2 system, which consists of connection bases for interfaces and connection cables, can only be connected to modules which are fitted with 40-pin connectors.

Several base types can be identified:

- connection interface bases for 8/12/16-channel discrete inputs/outputs
- bases for connection and adaptation interfaces for inputs with 16 isolated channels
- bases for connection and adaptation interfaces for static outputs with 8 and 16 channels
- bases for connection and adaptation interfaces relating to relay outputs with 8 and 16 channels
- bases for adapter splitting 16 channels into 2 x 8 channels
- bases for connection and adaptation interfaces relating to outputs, with or without removable electromechanical or static relays, with 16 channels
- input bases for 12.5-mm wide static relays

TELEFAST 2 Connection Bases Catalog

At a Glance

The catalog of TELEFAST 2 bases for discrete input/output modules is shown here.

Catalog

The table below shows the catalog of connection interface bases for 8/12/16-channel discrete I/Os.

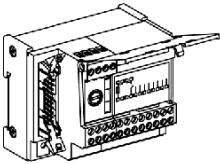
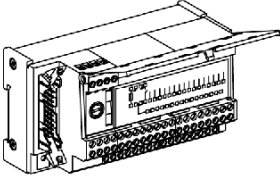
Reference ABE-7H**	08R10 08R11 08R21	08S21	12R50 16R50	12R10 12R20 12R21	16R10 16R11 16R20 16R21 16R23 16R30 16R31	12S21 16S21	16S43 (1) 16F43 (2)
Base types	Connection interface bases for 8/12/16-channel discrete I/Os.						
Sub groups	8-channel bases		Compact 12 and 16-channel bases	12 and 16-channel bases			
Illustration	TELEFAST 2 base 			TELEFAST 2 base 			
Description	-	with 1 isolator/channel	-	-	with 1 isolator/channel	with 1 fuse + 1 isolator/channel	

(1) for inputs
(2) for outputs

Illustration

The principle for identifying the connection interface bases for 8/12/16-channel discrete I/Os is as follows.

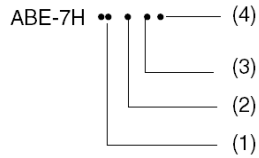

Description

The table below describes the different elements which make it possible to identify the connection interface bases for 8/12/16-channel discrete I/Os.

Number	Description
(1)	08 = 8-channel base 12 = 12-channel base 16 = 16-channel base
(2)	Primary function: <ul style="list-style-type: none"> ● R = simple connection ● S = isolator/channel ● F = fuse/channel
(3)	1 = with 1 screw terminal per channel on 1 level 2 = with 2 screw terminals per channel on 2 levels 3 = with 3 screw terminals per channel on 3 levels 4 = with 2 screw terminals per channel on 1 level 5 = with 1 screw terminal per channel on 2 levels
(4)	0 or even number = without LED display per channel odd number = with LED display per channel

Catalog

The table below shows the catalog of bases for connection and adaptation interfaces for inputs with 16 isolated channels.

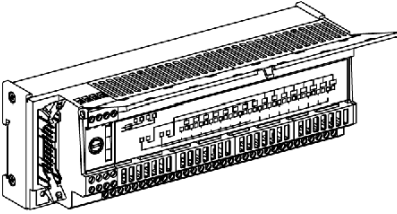
ABE-7S** reference	16E2B1	16E2E1	16E2E0	16E2F0	16E2M0
Base types	Bases for connection and adaptation interfaces for inputs with 16 isolated channels.				
Illustration	TELEFAST 2 base 				
Description	16 x 24 VDC inputs	16 x 48 VDC inputs	16 x 48 VAC inputs	16 x 110...120 VAC inputs	16 x 220...240 VAC inputs

The table below shows the catalog of bases for connection and adaptation interfaces for static outputs with 8 and 16 channels.

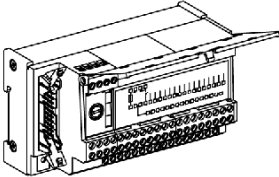
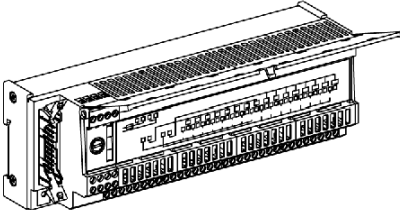
ABE-7S** reference	08S2B0	08S2B1	16S2B0	16S2B2
Base types	Bases for connection and adaptation interfaces for static outputs with 8 and 16 channels.			
Sub groups	8-channel bases		16-channel bases	
Illustration	TELEFAST 2 base 		TELEFAST 2 base 	
Description	8 static 24 VDC / 0.5A outputs, with error detection transfer to PLC.	8 static 24 VDC / 2A outputs, with error detection transfer to PLC.	16 static 24 VDC / 0.5A outputs, with error detection transfer to PLC.	16 static 24 VDC / 0.5A outputs, without error detection transfer to PLC.

The table below shows the catalog of bases for connection and adaptation interfaces for relay outputs with 8 and 16 channels.

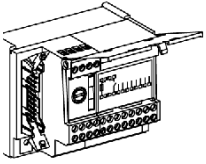
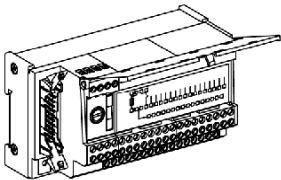
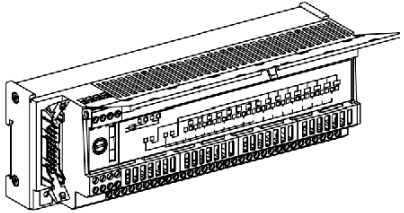
ABE-7R•• reference	08S111	08S210	16S111	16S210	16S212
Base types	Bases for connection and adaptation interfaces for relay outputs with 8 and 16 channels.				
Sub groups	8-channel bases		16-channel bases		
Illustration	TELEFAST 2 base 	TELEFAST 2 base 	TELEFAST 2 base 		
Description	8 relay outputs, 1 F with + or alternating polarity distribution.	8 relay outputs, 1 F, potential free contact.	16 relay outputs, 1 F, 2 x 8 shared + or alternating.	16 relay outputs, 1 F, potential free contact.	16 relay outputs, 1 F with distribution of the 2 polarities by 8-channel group.

The table below displays the catalog entry showing the connection base for the adapter splitting 16 channels into 2 x 8 channels.

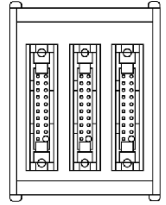
ABE-7A•• reference	CC02
Base types	Bases for adapter splitting 16 channels into 2 x 8 channels.
Illustration	TELEFAST 2 base 
Description	Allows splitting of: <ul style="list-style-type: none"> ● 16 channels into two x 8 channels ● 12 channels into 8 channels + 4 channels

The table below shows the catalog of output adaptation interface bases with or without removable electromechanical or static relays with 16 channels.

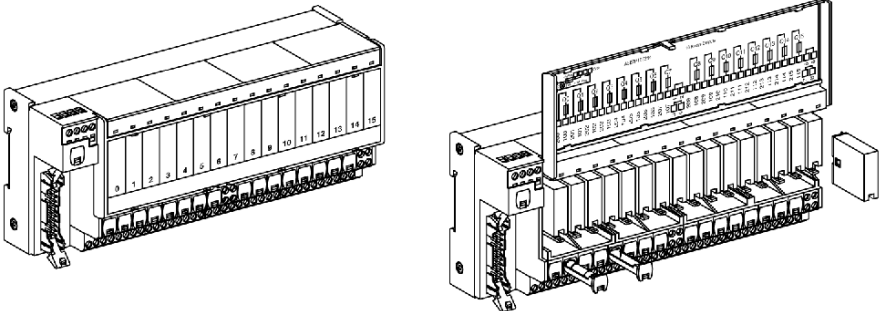
ABE-7** reference	R16T210	P16T210	P16T214	R16T212	P16T212	P16T215	P16T318
Base types	Output adaptation interface bases with or without removable electromechanical or static relays with 16 channels						
Sub groups	Output bases, 1 F, potential free contact.			Output bases, 1 F, distribution of the 2 polarities by 8-channel group.		Output base, 1 F, distribution of the 2 polarities by 4-channel group.	
Illustration	 <p>TELEFAST 2 base</p>						
Description	with 10-mm wide electro-mechanical relay	10-mm wide relay not provided	10-mm wide relay not provided, 1 fuse/channel	with 10-mm wide electro-mechanical relay	10-mm wide relay not provided	10-mm wide relay not provided, 1 fuse/channel	12.5-mm wide relay, not provided, 1 fuse + 1 isolator/channel

The table below shows the catalog of output adaptation interface bases with or without removable electromechanical or static relays with 16 channels (continued).

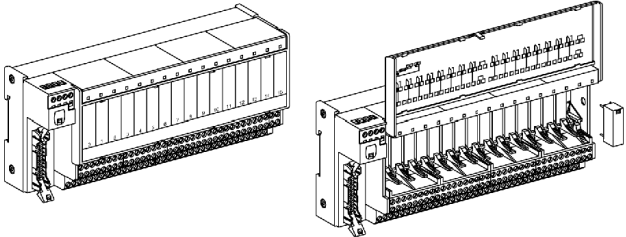
ABE-7** reference	R16T230	R16T330	P16T330	P16T334	R16T231	R16T332	P16T332	R16T370
Base types	Output adaptation interface bases with or without removable electromechanical or static relay with 16 channels (continued).							
Sub groups	Output bases, 1 OF, potential free contact.				Output bases, 1 OF, shared by 8-channel group.	Output bases, 1 OF, distribution of the 2 polarities by 8-channel group.		Output bases, 2 OF, potential free contact.
Illustration	<p>TELEFAST 2 base</p> 							
Description	with 10-mm wide electro-mechanical relay	with 12.5-mm wide electro-mechanical relay	12.5-mm wide relay, not provided	12.5-mm wide relay, not provided, 1 fuse/channel	with 10-mm wide electro-mechanical relay	with 12.5-mm wide electro-mechanical relay	12.5-mm wide relay, not provided	with 12.5-mm wide electro-mechanical relay

The table below shows the catalog of input bases for 12.5-mm wide static relays.

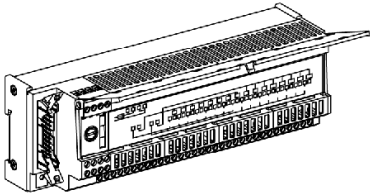
ABE-7P** reference	16F310	16F312
Base types	Input bases for 12.5-mm wide static relays	
Illustration	<p>TELEFAST 2 base</p> 	
Description	potential free	distribution of the 2 polarities by 8-channel group

Combination of Premium I/O modules and TELEFAST 2 connection bases

At a Glance

The following shows the possible combinations of Discrete I/O modules and **TELEFAST 2** connection bases.

Compatibility table

The following table summarizes compatibility between Discrete I/O modules and **TELEFAST 2** connection bases.

	TSX ** Discrete I/O modules and modularity								
	DEY 16FK	DEY 32D2K DEY 64D2K		DEY 32D3K	DSY 32T2K DSY 64T2K		DMY 28FK DMY 28RFK		
	1 x 16 I	2 x 16 I	4 x 16 I	2 x 16 I	2 x 16 O	4 x 16 O	1 x 16 I	1 x 12 O	
TELEFAST 2 connection bases									
Connection bases									
8 channels									
ABE-7H08R**	Yes (1)	Yes (1)	Yes (1)	-	Yes (1)	Yes (1)	Yes (1)	-	
ABE-7H08S21	Yes (1)	Yes (1)	Yes (1)	-	Yes (1)	Yes (1)	Yes (1)	-	
12 channels									
ABE-7H12R**	-	-	-	-	-	-	-	Yes	
ABE-7H12S21	-	-	-	-	-	-	-	Yes	
16 channels									
ABE-7H16R**	Yes	Yes	Yes	Yes (2)	Yes	Yes	Yes	-	
ABE-7H16S21	Yes	Yes	Yes	-	Yes	Yes	Yes	-	
ABE-7H16R23	Yes	Yes	Yes	-	-	-	Yes	-	
ABE-7H16F43	-	-	-	-	Yes	Yes	-	-	
ABE-7H16S43	Yes	Yes	Yes	-	-	-	Yes	-	
Input adapter connection bases									
16 channels									
ABE-7S16E2**	Yes	Yes	Yes	-	-	-	Yes	-	
ABE-7P16F3**	Yes	Yes	Yes	-	-	-	Yes	-	
Output adapter connection bases									
8 channels									
ABE-7S08S2**	-	-	-	-	Yes (1)	Yes (1)	-	-	
ABE-7R08S***	-	-	-	-	Yes (1)	Yes (1)	-	-	

	TSX ** Discrete I/O modules and modularity							
	DEY 16FK	DEY 32D2K DEY 64D2K		DEY 32D3K	DSY 32T2K DSY 64T2K		DMY 28FK DMY 28RFK	
	1 x 16 I	2 x 16 I	4 x 16 I	2 x 16 I	2 x 16 O	4 x 16 O	1 x 16 I	1 x 12 O
TELEFAST 2 connection bases								
16 channels								
ABE-7R16S***	-	-	-	-	Yes	Yes	-	-
ABE-7R16T***	-	-	-	-	Yes	Yes	-	-
ABE-7P16T***	-	-	-	-	Yes	Yes	-	-
Legend:								
(1)	With 16 to 2 x 8 channel adapter ABE-7ACC02 .							
(2)	With ABE-7H16R20 connection base only.							

31.2 Connection Principles for the TELEFAST 2 Interfaces for Discrete I/O

Aim of this section

This section describes the connection principles for the **TELEFAST 2** products for discrete input/output modules.

What's in this Section?

This section contains the following topics:

Topic	Page
Connecting a Discrete I/O module to a TELEFAST 2 base interface	262
Dimensions and Mounting of the TELEFAST 2 Connection Bases	263

Connecting a Discrete I/O module to a TELEFAST 2 base interface

At a Glance

The connection of a Discrete I/O module with a **HE10** connector to the **TELEFAST 2** connection base is performed by way of a multi-strand sheathed ribbon cable or connection cable (see page 48).

Illustration

The following diagram shows the connection of a Discrete I/O module with a **HE10** connector to a **TELEFAST 2** connection base.

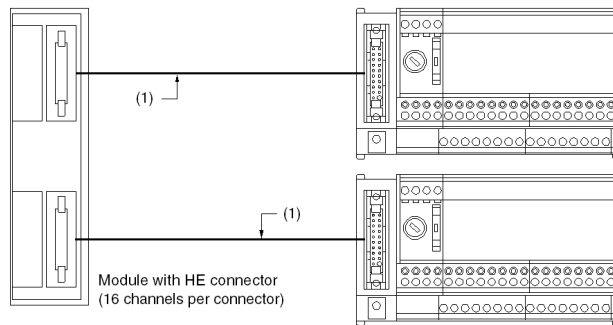

(1) TSX CDP •02 ribbon cable or TSX CDP ••3 cable.

Illustration

The following diagram shows an example specific to the connection of 16 channels in 2 x 8 channel groups via the **ABE-7ACC02** adapter base.

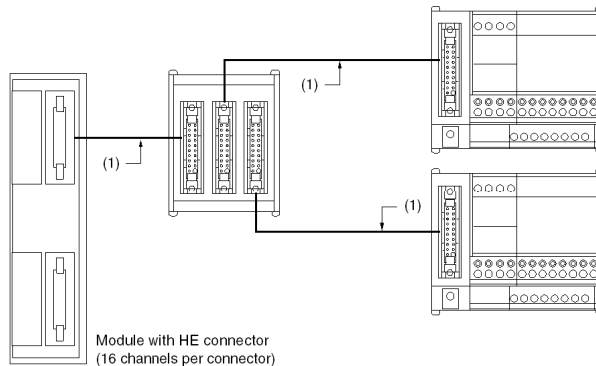

(1) TSX CDP •02 ribbon cable or TSX CDP ••3 cable.

Dimensions and Mounting of the TELEFAST 2 Connection Bases

At a Glance

Here is an overview of the dimensions of different TELEFAST 2 connection products and their mounting methods.

Illustration

The illustration below shows the dimensions (in mm) of the products: ABE-7H••R1•, ABE-7H••R5•, ABE-7H••R2•, ABE-7H••S21, ABE-7H16R3•, ABE-7S08S2B0, ABE-7R••S1••, ABE-7R08S210.

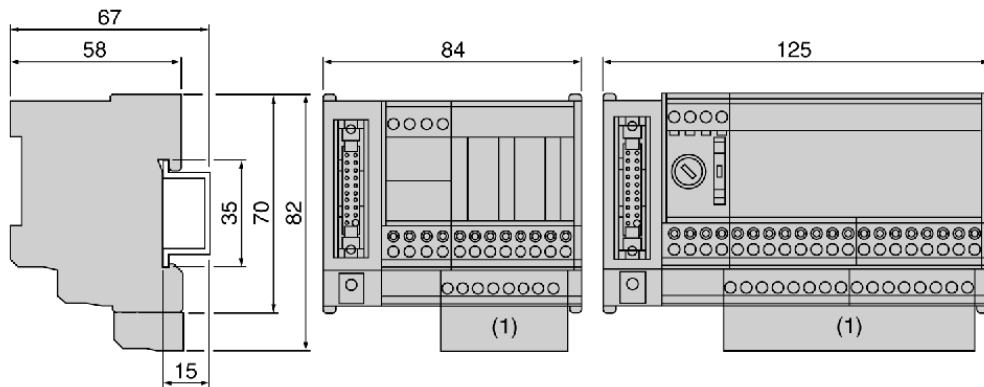

(1) Dimension with additional shunt terminal block ABE-7BV20 or ABE-7BV10.

The illustration below shows the dimensions (in mm) of the products: ABE-7H16S43, ABE-7S16E2••, ABE-7S08S2B1, ABE-7S16S2B•, ABE-7H16F43•, ABE-7R16S21.

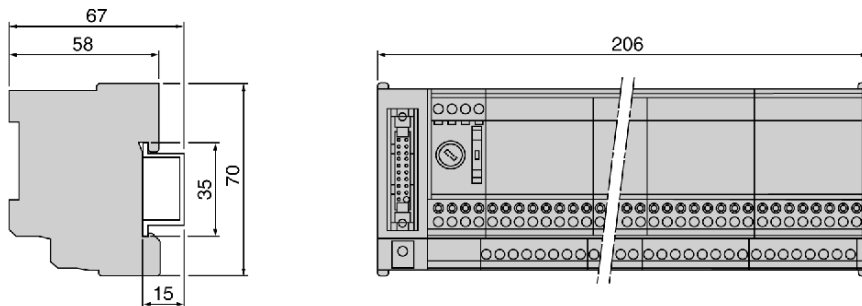

The illustration below shows the dimensions (in mm) of the product ABE-7ACC02.

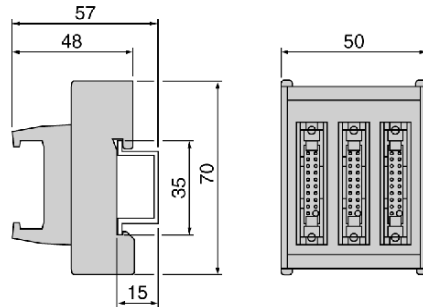

The illustration below shows the dimensions (in mm) of the products: ABE-7R16T2** and ABE-7P16T2**.

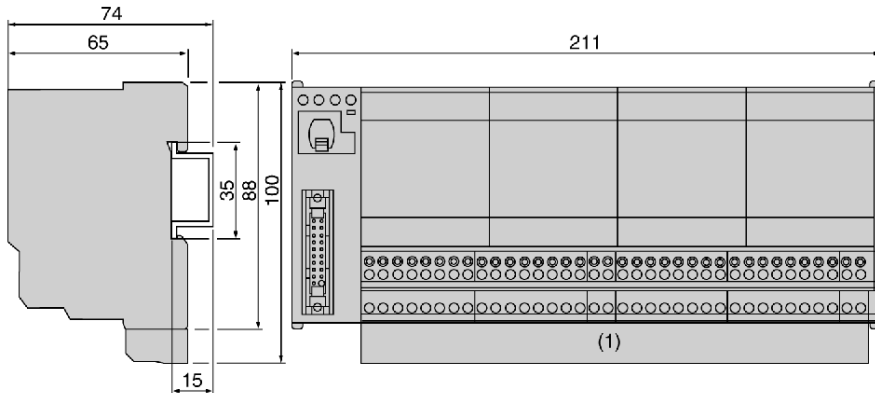

Reference measuring 211 x 88 mm (product shown has removable relays and non-mounted screws).

(1) Dimension with additional shunt terminal block ABE-7BV20 or ABE-7BV10.

The illustration below shows the dimensions (in mm) of the products: ABE-7R16T3•• and ABE-7P16T3••.

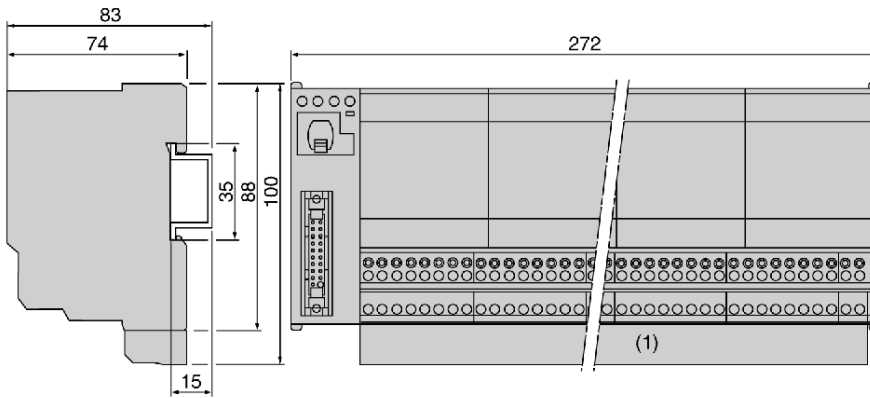

Reference measuring 272 x 88 mm (product shown has removable relays and non-mounted screws).

(1) Dimension with additional shunt terminal block ABE-7BV20 or ABE-7BV10.

Mounting

The TELEFAST 2 bases are mounted on 35-mm wide DIN mounting rails.

⚠ WARNING

UNEXPECTED EQUIPMENT OPERATION

Install the input adaptation bases ABE-7S16E2E1 and static output adaptation bases ABE-7S••S2B• lengthways and horizontally to prevent the device from overheating and unexpected operation.

Failure to follow these instructions can result in death, serious injury, or equipment damage.

31.3 TELEFAST 2 ABE-7H08R10/08R11 and ABE-7H16R10/16R11 Connection Bases

Sensor and Pre-actuator Connections on the ABE-7H08R10/R11 and ABE-7H16R10/R11 Bases

At a Glance

This is an overview of the sensor and pre-actuator connections on TELEFAST 2 bases.

NOTE: The bases are manufactured with a general-purpose, quick-blow fuse rated 6.3 A. To guarantee optimum protection, this fuse should be rated according to the application (connection to input or output functions) and the maximum current allowable in the base.

Type and rating of fuse to be fitted to the base:

- input functions: 0.5 A quick-blow
- output functions:
 - 2 A quick-blow on the ABE-7H16R** base
 - 6.3 A quick-blow on the ABE-7H08R** base

Illustration

Description of the connection terminal blocks.

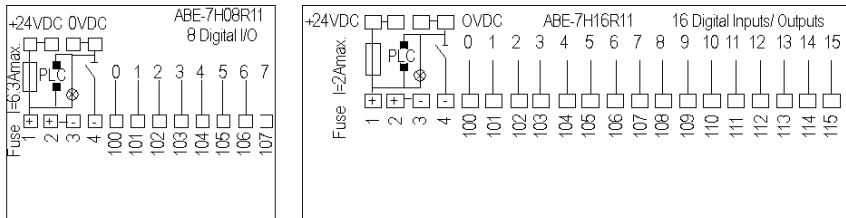

Illustration

Connections for input and output functions.

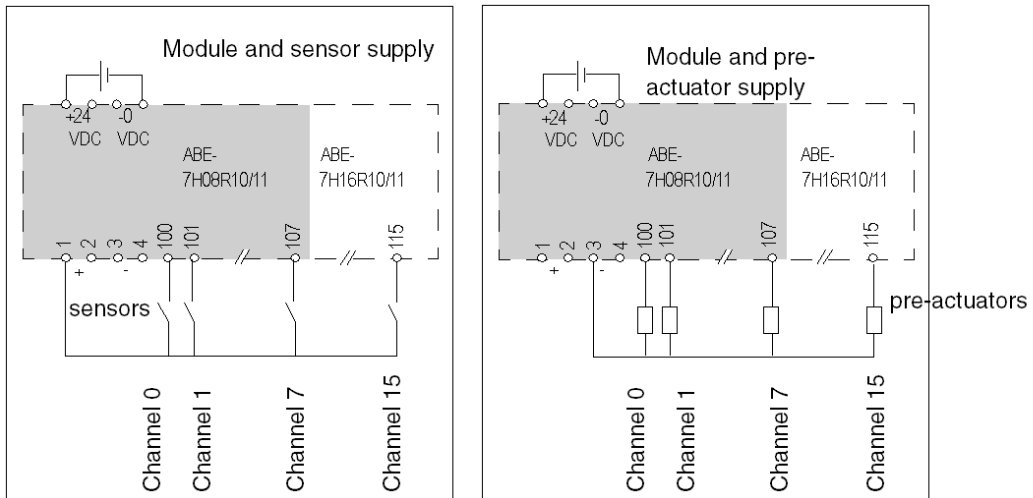

Connecting the common for sensors:

- onto terminals 1 or 2: sensors to the '+' of the supply (positive logic inputs)

Connecting the common for pre-actuators:

- onto terminals 3 or 4: pre-actuators to the '-' of the supply (positive logic outputs)

31.4 TELEFAST 2 ABE-7H12R10/12R11 Connection Bases

Sensor and Pre-actuator Connections on the ABE-7H12R10/R11 Bases

At a Glance

This is an overview of the sensor and pre-actuator connections on TELEFAST 2 bases.

NOTE: The bases are manufactured with a general-purpose, quick-blow fuse rated 6.3 A. To guarantee optimum protection, this fuse should be rated according to the application (connection to input or output functions) and the maximum current allowable in the base.

Type and rating of fuse to be fitted to the base:

- input functions: 0.5 A quick-blow
- output functions: 6.3 A quick-blow on the ABE-7H12R ••base

Illustration

Description of the connection terminal blocks.

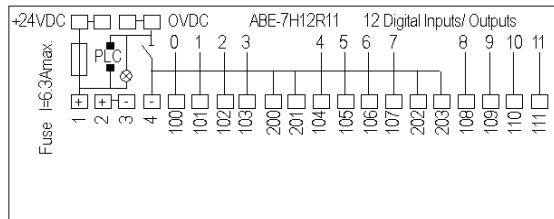

Illustration

Connections for input and output functions.

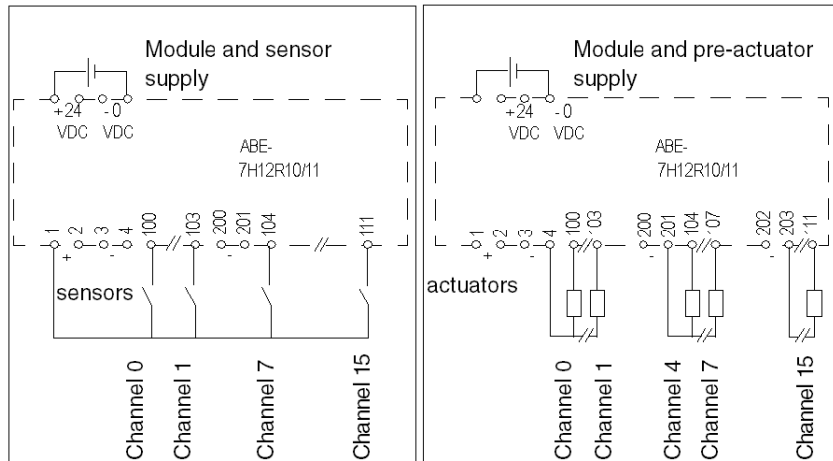

Connecting the common for sensors:

- onto terminals 1 or 2: sensors to the '+' of the supply (positive logic inputs)

Connecting the common for pre-actuators:

- several terminals linked to the '-' polarity (3, 4, 200, 201, 202, and 203) allowing sharing in groups of 4 or 2 channels (positive logic outputs)

31.5 TELEFAST 2 ABE-7H08R21 and ABE-7H16R20/16R21/16R23 Connection Bases

Sensor and Pre-actuator Connections on the ABE-7H08R21 and ABE-7H16R20/R21/R23 Bases for Type 2 Inputs

At a Glance

This is an overview of the sensor and pre-actuator connections on TELEFAST 2 bases.

NOTE: The bases are manufactured with a general-purpose, quick-blow fuse rated 2 A. To guarantee optimum protection, this fuse should be rated according to the application (connection to input or output functions) and the maximum current allowable in the base.

Type and rating of fuse to be fitted to the base:

- input functions: 0.5 A quick-blow
- output functions:
 - 2 A quick-blow on the ABE-7H16R** base
 - 6.3 A quick-blow on the ABE-7H08R** base

Illustration

Description of the connection terminal blocks.

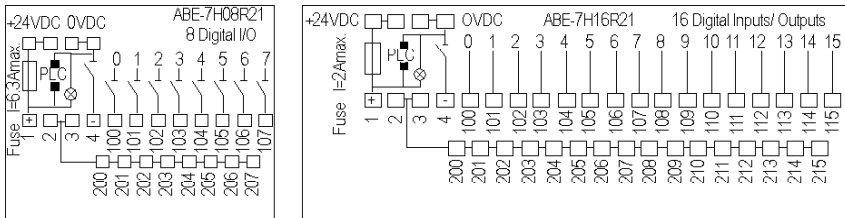

Illustration

Connections for input and output functions.

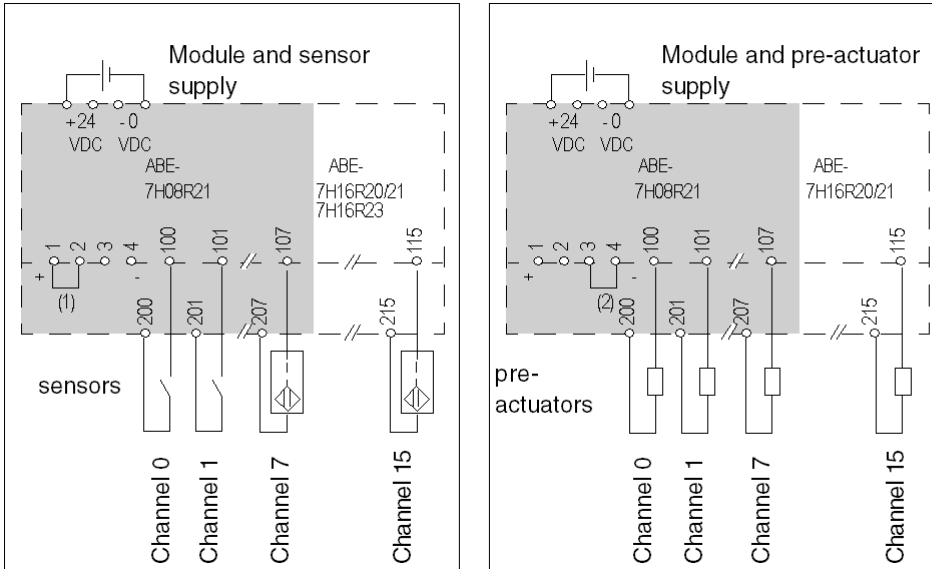

Connecting the common for sensors:

- In order to create the shared sensor supply, position the jumper (1) on terminals 1 and 2: terminals 200 to 215 will be on the '+' of the supply (positive logic inputs).

Connecting the common for pre-actuators:

- In order to create the shared supply for the pre-actuators, position the jumper (2) on terminals 3 and 4: terminals 200 to 215 will be on the '-' of the supply (positive logic outputs).

31.6 TELEFAST 2 ABE-7H12R20/12R21 Connection Bases

Sensor and Pre-actuator Connections on the ABE-7H12R20/12R21 Bases

At a Glance

This is an overview of the sensor and pre-actuator connections on TELEFAST 2 bases.

NOTE: The bases are manufactured with a general-purpose, quick-blow fuse rated 6.3 A. To guarantee optimum protection, this fuse should be rated according to the application (connection to input or output functions) and the maximum current allowable in the base.

Type and rating of fuse to be fitted to the base:

- input functions: 0.5 A quick-blow
- output functions: 6.3 A quick-blow on the ABE-7H12R21 base

Illustration

Description of the connection terminal blocks.

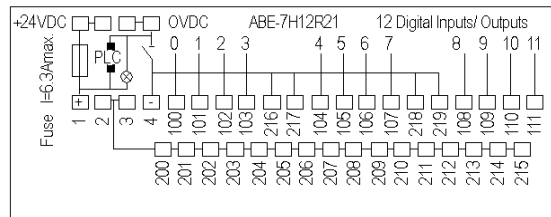

Illustration

Connections for input and output functions.

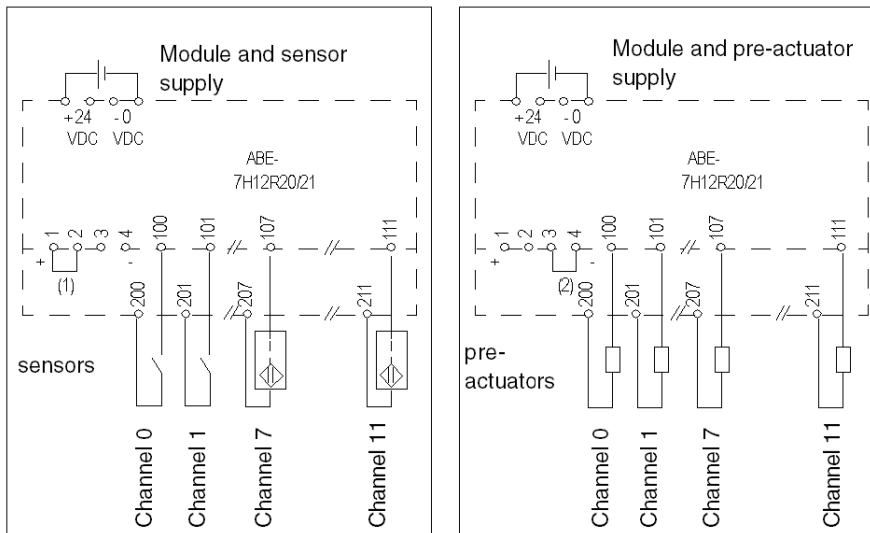

Connecting the common for sensors:

- In order to create the shared sensor supply, position the jumper (1) on terminals 1 and 2: terminals 200 to 215 will be on the '+' of the supply (positive logic inputs). Terminals 216, 217, 218 and 219 are linked to the '-' polarity.

Connecting the common for pre-actuators:

- In order to create the shared supply for the pre-actuators, position the jumper (2) on terminals 3 and 4: terminals 200 to 215 will be on the '-' of the supply (positive logic outputs). Terminals 216, 217, 218 and 219 are linked to the '-' polarity

31.7 TELEFAST 2 ABE-7H08S21/16S21 Connection Bases

Sensor and Pre-actuator Connections on ABE-7H08S21/16S21 Bases with One Isolator per Channel

At a Glance

This is an overview of the sensor and pre-actuator connections on TELEFAST 2 bases.

NOTE: The bases are manufactured with a general-purpose, quick-blow fuse rated 2 A. To guarantee optimum protection, this fuse should be rated according to the application (connection to input or output functions) and the maximum current allowable in the base.

Type and rating of fuse to be fitted to the base:

- input functions: 0.5 A quick-blow
- output functions:
 - 2 A quick-blow on the ABE-7H16S21 base
 - 6.3 A quick blow on the ABE-7H08S21 base

Illustration

Description of the connection terminal blocks.

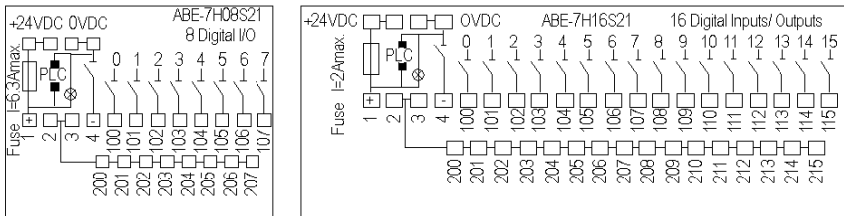

Illustration

Connections for input and output functions.

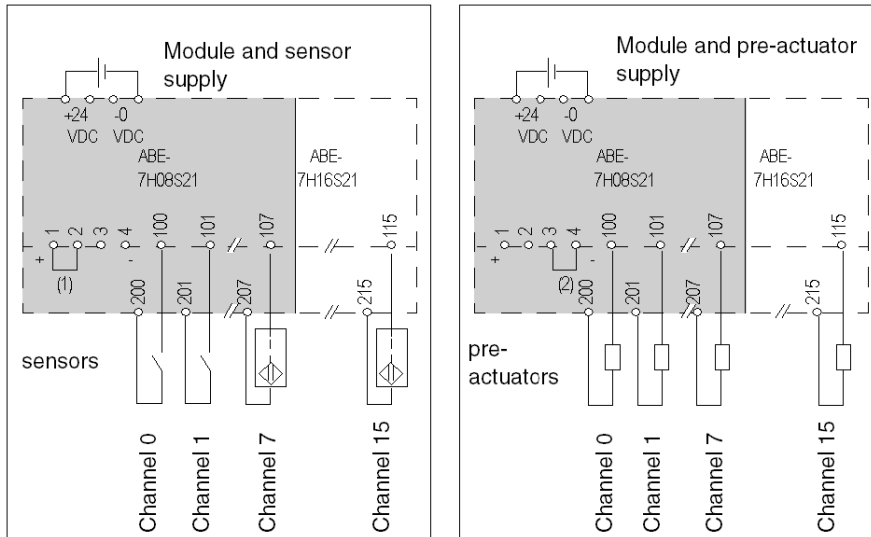

Connecting the common for sensors:

- In order to create the shared sensor supply, position the jumper (1) on terminals 1 and 2: terminals 200 to 215 will be on the '+' of the supply (positive logic inputs).

Connecting the common for actuators:

- In order to create the shared supply for the actuators, position the jumper (2) on terminals 3 and 4: terminals 200 to 215 will be on the '-' of the supply (positive logic outputs).

31.8 TELEFAST 2 ABE-7H12S21 Connection Base

Sensor and Pre-actuator Connections on the ABE-7H12S21 Base with 1 Isolator per Channel

At a Glance

This is an overview of the sensor and actuator connections on the TELEFAST 2 base.

NOTE: The base is manufactured with a general-purpose, quick-blow fuse rated 6.3 A. To guarantee optimum protection, this fuse should be rated according to the application (connection to input or output functions) and the maximum current allowable in the base.

Type and rating of fuse to be fitted to the base:

- input functions: 0.5 A quick-blow
- output functions: 6.3A quick-blow on the ABE-7H12S21 base

Illustration

Description of the connection terminal blocks.

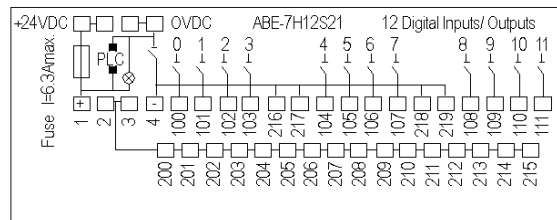

Illustration

Connections for input and output functions.

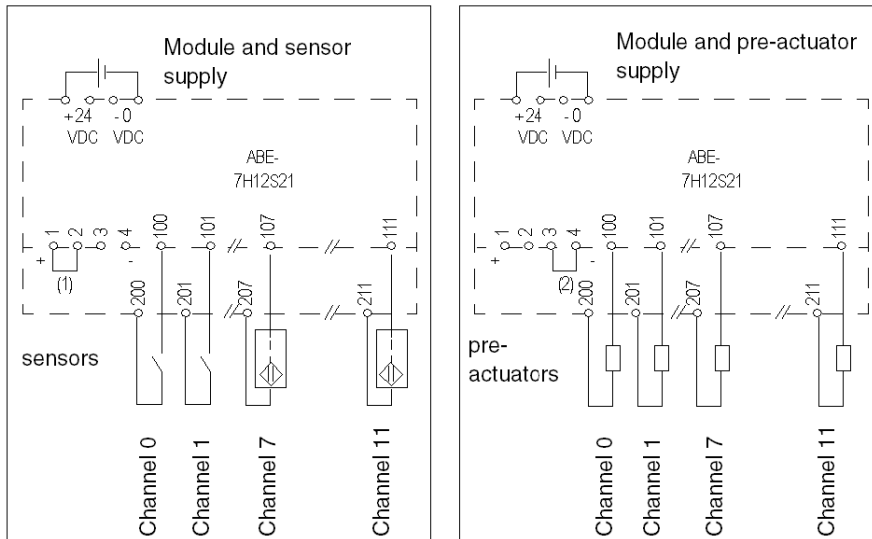

Connecting the common for sensors:

- In order to create the shared sensor supply, position the jumper (1) on terminals 1 and 2: terminals 200 to 215 will be on the '+' of the supply (positive logic inputs). Terminals 216, 217, 218 and 219 are linked to the '-' polarity.

Connecting the common for pre-actuators:

- In order to create the shared supply for the pre-actuators, position the jumper (2) on terminals 3 and 4: terminals 200 to 215 will be on the '-' of the supply (positive logic outputs). Terminals 216, 217, 218 and 219 are linked to the '+' polarity.

31.9 TELEFAST 2 ABE-7H16R30/16R31 Connection Bases

Sensor and Pre-actuator Connections on the ABE-7H16R30/R31 Bases

At a Glance

This is an overview of the sensor connections on TELEFAST 2 bases.

NOTE: The bases are manufactured with a general-purpose, quick-blow fuse rated 2 A. To guarantee optimum protection, this fuse should be rated according to the application and the maximum current allowable in the base.

Type and rating of fuse to be fitted to the base:

- input functions: 0.5A quick-blow

Illustration

Description of the connection terminal blocks.

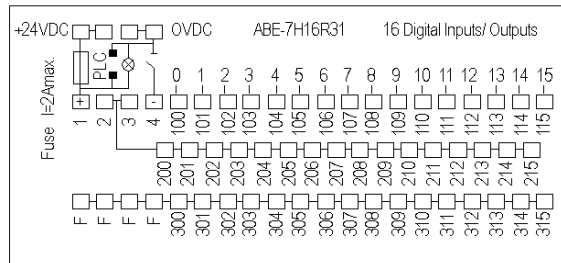

Illustration

Input function connections.

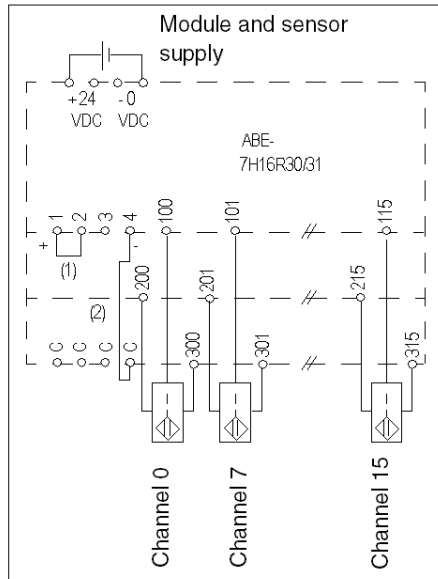

Connecting the common for sensors:

- to create the shared sensor supply:
 - position the jumper wire (1) on terminals 1 and 2: terminal blocks 200 to 215 will be at the "+" of the supply
 - link terminal 4 to one of the C terminals of the 3rd level (2): terminal blocks 300 to 315 will be at the "-" of the supply

NOTE: The ABE-7H16R30/R31 base can also be used for connecting actuators.

31.10 TELEFAST 2 ABE-7H12R50 Connection Base

Sensor and Pre-actuator Connections on the ABE-7H12R50 Bases

At a Glance

This is an overview of the sensor and pre-actuator connections on the TELEFAST 2 base.

NOTE: The base is manufactured with a general-purpose, quick-blow fuse rated 6.3 A. To guarantee optimum protection, this fuse should be rated according to the application (connection to input or output functions) and the maximum current allowable in the base.

Type and rating of fuse to be fitted to the base:

- input functions: 0.5 A quick-blow
- output functions: 6.3 A quick-blow on the ABE-7H12R50 base

Illustration

Description of the connection terminal blocks.

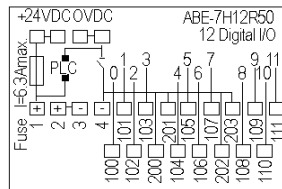

Illustration

Connections for input and output functions.

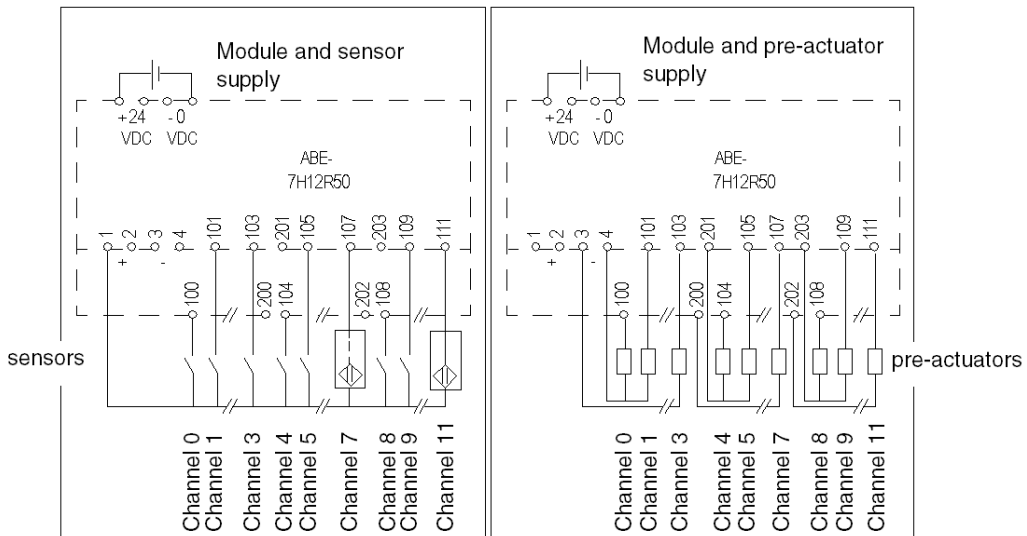

Connecting the common for sensors:

- onto terminals 1 or 2: sensors to the '+' of the supply (positive logic inputs).
Terminals 200, 201, 202 and 203 are linked to the '-' polarity

Connecting the common for pre-actuators:

- several terminals linked to the '-' polarity (3, 4, 200, 202, and 203) allow sharing in groups of 4 or 2 channels (positive logic outputs)

31.11 TELEFAST 2 ABE-7H16R50 Connection Base

Sensor and Actuator Connections on the ABE-7H16R50 Base

At a Glance

This is an overview of the sensor and actuator connections on the TELEFAST 2 base.

NOTE: The base is manufactured with a general-purpose, fast-blow fuse rated 6.3 A. To guarantee optimum protection, this fuse should be rated according to the application (connection to input or output functions) and the maximum current allowable in the base.

Type and rating of fuse to be fitted to the base:

- input functions: 0.5A fast blow
- output functions: 2A fast blow on the ABE-7H16R50 base

Illustration

Description of the connection terminal blocks.

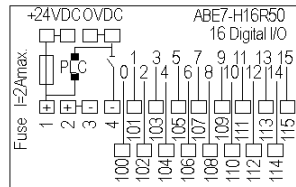

Illustration

Connections for input and output functions.

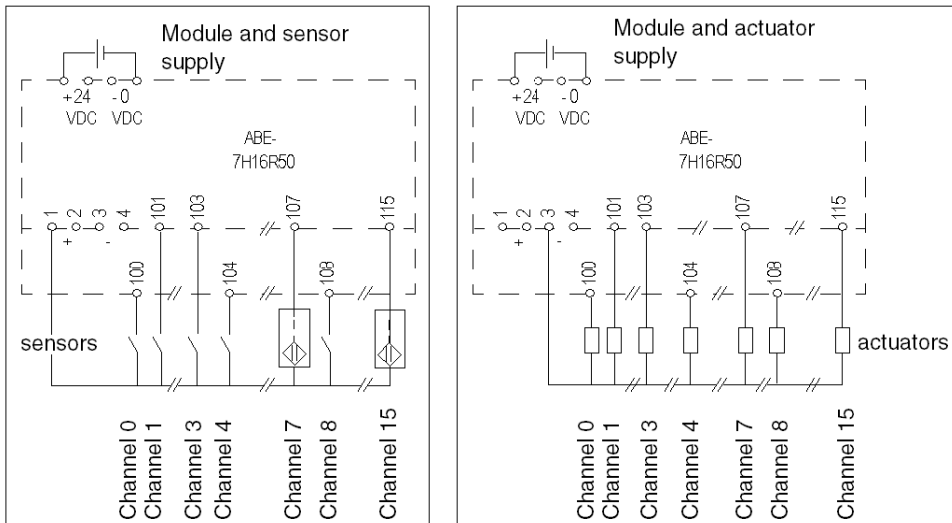

Connecting the common for sensors:

- onto terminals 1 or 2: sensors to the '+' of the supply (positive logic inputs)

Connecting the common for actuators:

- onto terminals 3 or 4: actuators to the '-' of the supply (positive logic outputs)

31.12 TELEFAST 2 ABE-7H16F43 Connection Base

Actuator Connections on ABE-7H16F43 Output Base with One Fuse and One Isolator per Channel

At a Glance

This is an overview of the actuator connections on TELEFAST 2 bases.

Illustration

Description of the connection terminal blocks.



Illustration

Output connection functions.

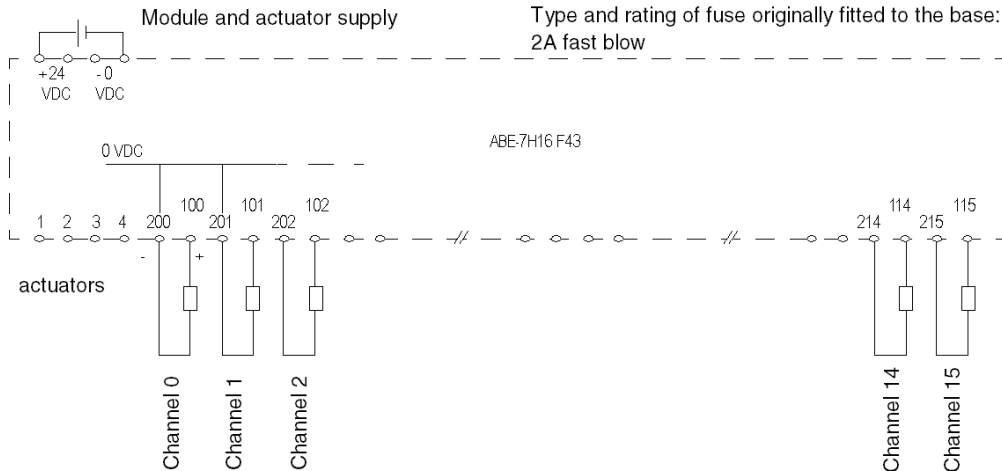

Functionality per channel:

- original fitted 0.125 A fuse
- isolator cuts the '-' and the channel signal simultaneously

NOTE: Terminals 200..215 are connected to the '-' polarity of the supply.

31.13 TELEFAST 2 ABE-7H16S43 Connection Base

Sensor Connections on ABE-7H16S43 Output Base with One Fuse and One Isolator per Channel

At a Glance

This is an overview of the sensor connections on TELEFAST 2 bases.

Illustration

Description of the connection terminal blocks.

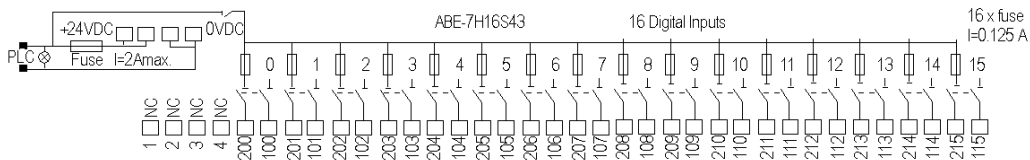

Illustration

Input function connections.

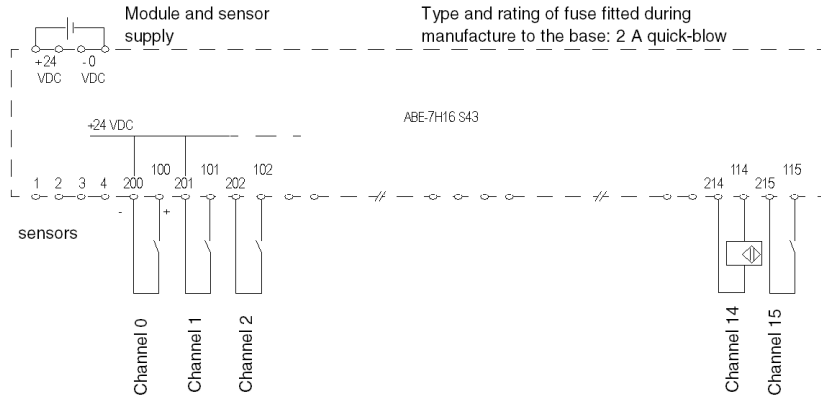

Functionality per channel:

- 0.125 A fuse fitted during manufacture
- isolator cuts the '+' and the channel signal simultaneously

NOTE: Terminals 200...215 are connected to the '+' polarity of the supply.

31.14 TELEFAST 2 ABE-7R08S111/16S111 connection bases

Aim of this section

This section introduces the **TELEFAST 2 ABE-7R08S111/16S111** connection bases.

What's in this Section?

This section contains the following topics:

Topic	Page
Actuator connections on non removable relay output adaptation bases ABE-7R08S111/16S111.	287
Characteristics of non removable relay output adaptation bases ABE-7R08S111/16S111.	289

Actuator connections on non removable relay output adaptation bases ABE-7R08S111/16S111.

At a Glance

This is a description of the actuator connections on:

- base **TELEFAST 2 ABE-7R08S111**, 8 relay outputs, 1 F twice , 4 common DC or AC currents;
- base **TELEFAST 2 ABE-7R16S111**, 16 relay outputs, 1 F twice , 8 common DC or AC currents.

Illustration

Description of the connection terminal blocks.

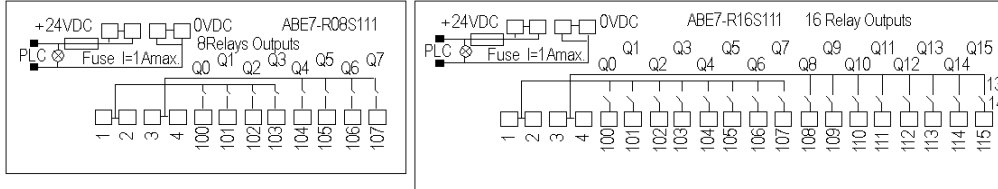

Illustration

Output connection functions.

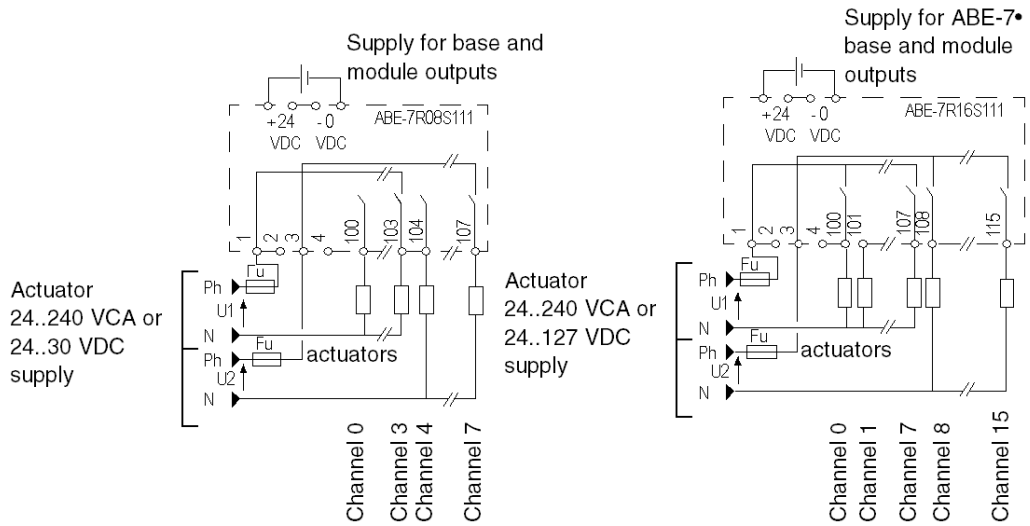

Fu Fuse rating according to the load.

NOTE: The bases are originally equipped with a general-purpose, fast-blow fuse rated 1 A.

Protection of relay contacts:

- a protection circuit must be mounted onto the terminals of each actuator:
 - RC or MOV circuit in the case of alternating current;
 - discharge diode for direct current.

Characteristics of non removable relay output adaptation bases ABE-7R08S111/16S111.

At a Glance

This section describes the general characteristics of bases **TELEFAST 2 ABE-7R08S111/16S111**.

General characteristics

This table describes the general characteristics of bases **ABE-7R08S111/16S111**

Base types		ABE-7R08S111	ABE-7R16S111
Channel number		8	16
Contact characteristics			
Job limit voltage		Alternating	250 V
		Direct	30 V
Thermal current		3 A	
Alternating current load	Resistive, load AC12	Voltage	230 VAC
		Current (1)	0.6 A
	Inductive, load AC15	Voltage	230 VAC
		Current (1)	0.4 A
Direct current load	Resistive, load DC12	Voltage	24 VDC
		Current (1)	0.6 A
	Inductive, load DC13 (2)	Voltage	24 VDC
		Current (1)	0.2 A
Minimum switching		Current	1 mA
		Voltage	5 V
Response time		State 0 to 1	10 ms
		State 1 to 0	6 ms
Maximum speed of function loading		0.5 Hz	
Built-in protection measures	Against overloads and short-circuits:	None, provide one rapid fusion fuse per channel or group of channels.	
	Against alternating current inductive overcharging	None, each RC circuit or MOV (ZNO) suppressor, must be mounted on the posts of each pre-actuator appropriate to the voltage.	
	Against direct current inductive overcharging	none, each discharge diode must be mounted on the posts of each pre-actuator.	

Base types		ABE-7R08S111	ABE-7R16S111
Voltage assigned to insulation	Coil/contact	300 V	
Voltage assigned to shock resistance (1.2/50)	Coil/contact	2.5 kV	
Key			
(1)	For 0.5×10^6 maneuvers.		
(2)	L/R = 10 ms.		

31.15 TELEFAST 2 ABE-7R08S210/16S210 connection bases

Aim of this section

This section introduces the **TELEFAST 2 ABE-7R08S210/16S210** connection bases.

What's in this Section?

This section contains the following topics:

Topic	Page
Actuator connections on non removable relay output adaptation bases ABE-7R08S210/16S210.	292
Characteristics of non removable relay output adaptation bases ABE-7R08S210/16S210.	294

Actuator connections on non removable relay output adaptation bases ABE-7R08S210/16S210.

At a Glance

This is an overview of the actuator connections on **TELEFAST 2 ABE-7R08S210/16S210** bases, 8 or 16 relay outputs, 1 F, potential free contact.

Illustration

Description of the connection terminal blocks.

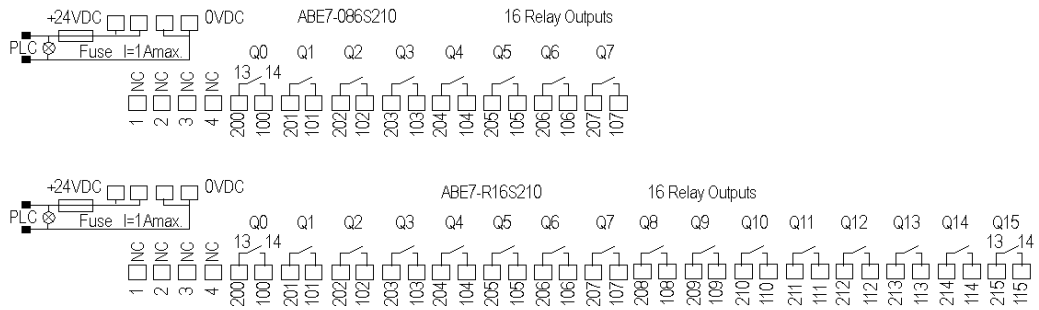

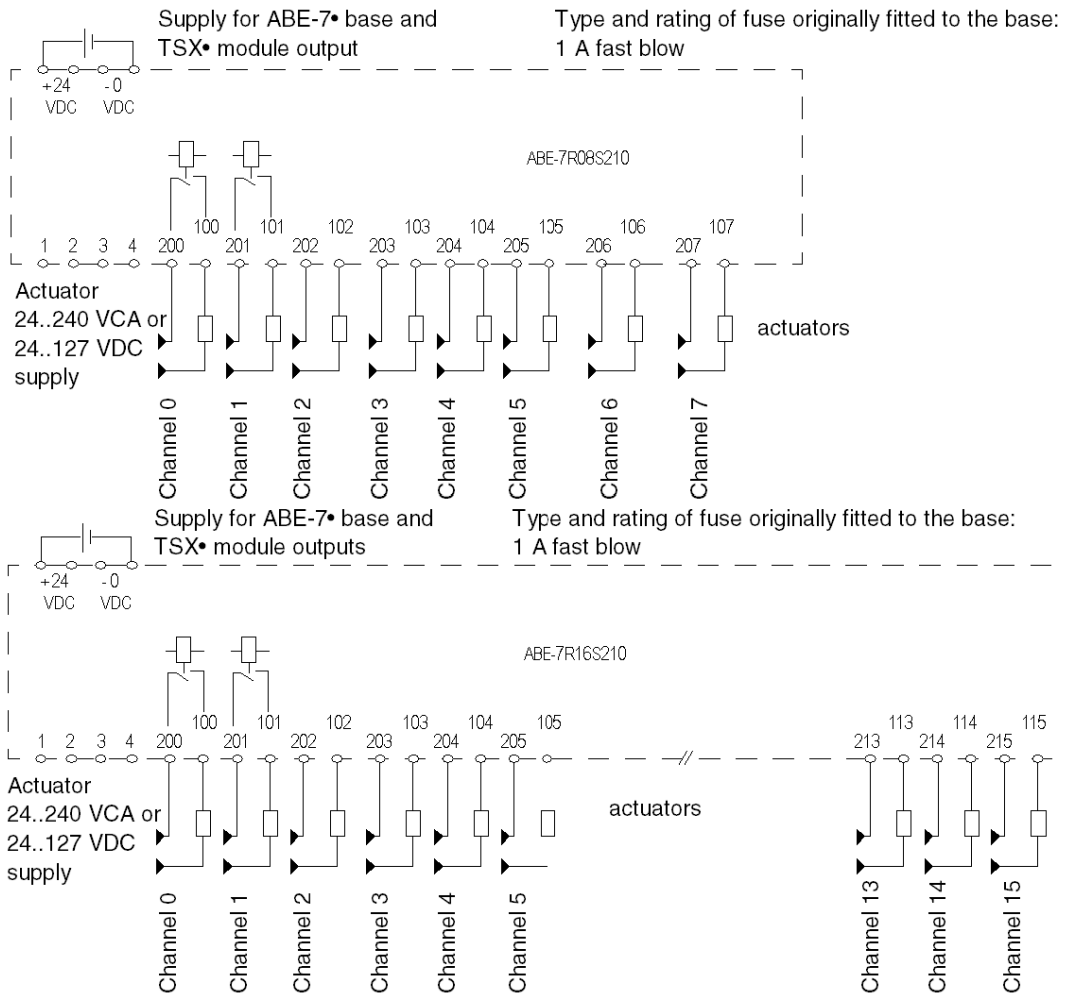
Illustration**Output connection functions.****NOTE:** Protection of relay contacts:

- a protection circuit must be mounted onto the terminals of each actuator:
 - RC or MOV circuit on alternating current;
 - discharge diode for direct current.

Characteristics of non removable relay output adaptation bases ABE-7R08S210/16S210.

At a Glance

This section describes the general characteristics of bases **TELEFAST 2 ABE-7R08S210/16S210**.

General characteristics

This table describes the general characteristics of bases **ABE-7R08S210/16S210**

Base types		ABE-7R08S210	ABE-7R16S210
Channel number		8	16
Contact characteristics			
Job limit voltage		Alternating	250 V
		Direct	125 V
Thermal current		5 A	
Alternating current load	Resistive, load AC12	Voltage	230 VAC
		Current (1)	1,5 A
	Inductive, load AC15	Voltage	230 VAC
		Current (1)	0.9 A
Direct current load	Resistive, load DC12	Voltage	24 VDC
		Current (1)	1.5 A
	Inductive, load DC13 (2)	Voltage	24 VDC
		Current (1)	0.6 A
Minimum switching		Current	10 mA
		Voltage	5 V
Response time		State 0 to 1	10 ms
		State 1 to 0	5 ms
Maximum speed of function loading		0.5 Hz	
Built-in protection measures	Against overloads and short-circuits:	None, provide one rapid fusion fuse per channel or group of channels.	
	Against alternating current inductive overcharging	None, each RC circuit or MOV (ZNO) suppressor, must be mounted on the posts of each pre-actuator appropriate to the voltage.	
	Against direct current inductive overcharging	None, each discharge diode must be mounted on the posts of each pre-actuator.	

Base types		ABE-7R08S210	ABE-7R16S210
Voltage assigned to insulation	Coil/contact	300 V	
Voltage assigned to shock resistance (1.2/50)	Coil/contact	2.5 kV	
Key			
(1)	For 0.5×10^6 maneuvers.		
(2)	L/R = 10 ms.		

31.16 TELEFAST 2 ABE-7R16S212 connection base

Aim of this section

This section describes the connection base **TELEFAST 2 ABE-7R16S212**.

What's in this Section?

This section contains the following topics:

Topic	Page
Actuator connections on non removable relay output adaptation bases ABE-7R16S212.	297
Characteristics of non removable relay output adaptation bases ABE-7R16S212.	298

Actuator connections on non removable relay output adaptation bases ABE-7R16S212.

At a Glance

This is an overview of the actuator connections for base **TELEFAST 2 ABE-7R16S212**, 16 relay outputs, 1F, with distribution of the polarities by 8 channel group.

Illustration

Description of the connection terminal blocks.

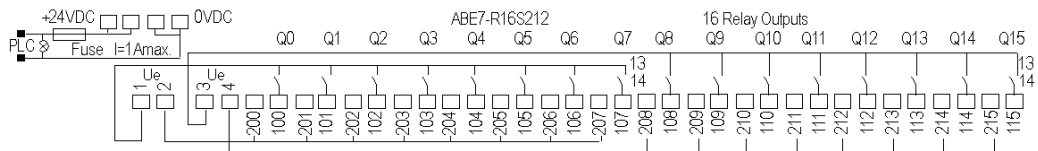

Illustration

Output connection functions.

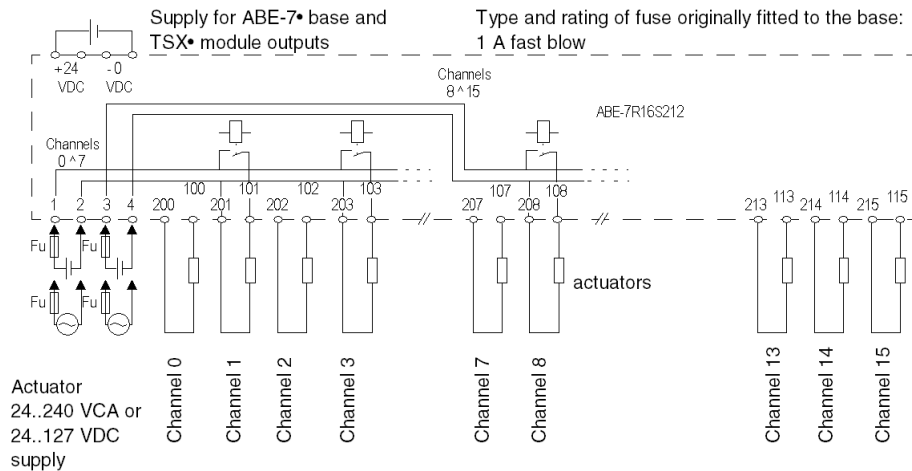

Fu Fuse rating according to the load.

NOTE: Protection of relay contacts:

- a protection circuit must be mounted onto the terminals of each actuator:
 - RC or MOV circuit on alternating current;
 - discharge diode for direct current.

Characteristics of non removable relay output adaptation bases ABE-7R16S212.

At a Glance

This section describes the general characteristics of base **TELEFAST 2 ABE-7R16S212**.

General characteristics

This table describes the general characteristics of base **ABE-7R16S212**

Base type		ABE-7R16S212	
Channel number		16	
Contact characteristics			
Job limit voltage		Alternating	250 V
		Direct	125 V
Thermal current		5 A	
Alternating current load	Resistive, load AC12	Voltage	230 VAC
		Current (1)	1.5 A
	Inductive, load AC15	Voltage	230 VAC
		Current (1)	0.9 A
Direct current load	Resistive, load DC12	Voltage	24 VDC
		Current (1)	1.5 A
	Inductive, load DC13 (2)	Voltage	24 VDC
		Current (1)	0,6 A
Minimum switching		Current	10 mA
		Voltage	5 V
Response time		State 0 to 1	10 ms
		State 1 to 0	5 ms
Maximum speed of function loading		0.5 Hz	
Built-in protection measures	Against overloads and short-circuits		None, provide one rapid fusion fuse per channel or group of channels.
	Against alternating current inductive overcharging		None, each RC circuit or MOV (ZNO) suppressor, must be mounted on the posts of each pre-actuator appropriate to the voltage.
	Against direct current inductive overcharging		None, each discharge diode must be mounted on the posts of each pre-actuator.
Voltage assigned to insulation		Coil/contact	300 V

Base type		ABE-7R16S212
Voltage assigned to shock resistance (1.2/50)	Coil/contact	2.5 kV
Key		
(1)	For 0.5×10^6 maneuvers.	
(2)	L/R = 10 ms.	

31.17 Connection bases TELEFAST 2 ABE-7S16E2B1/E2E1/E2E0/E2F0/E2M0

Aim of this section

This section introduces the **TELEFAST 2 ABE-7 S16E2B1/E2E1/E2E0/E2F0/E2M0** connection bases.

What's in this Section?

This section contains the following topics:

Topic	Page
Sensor connections on non removable static relay input adaptation bases ABE-7S16E2B1/E2E1/E2E0/E2F0/E2M0	301
Characteristics of non removable static relay input adaptation bases ABE-7S16E2B1/E2E1/E2E0/E2F0/E2M0	302

Sensor connections on non removable static relay input adaptation bases ABE-7S16E2B1/E2E1/E2E0/E2F0/E2M0

At a Glance

This is an overview of the sensor connections on **TELEFAST 2** bases.

Illustration

Description of the connection terminal blocks.

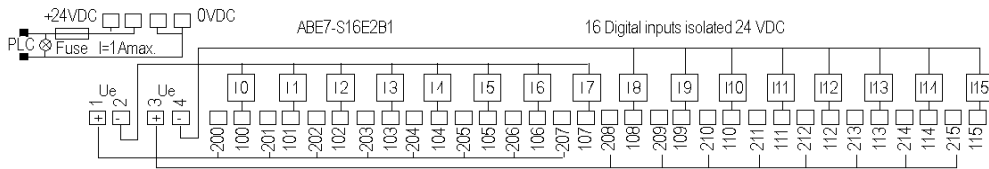

Illustration

Input function connections.

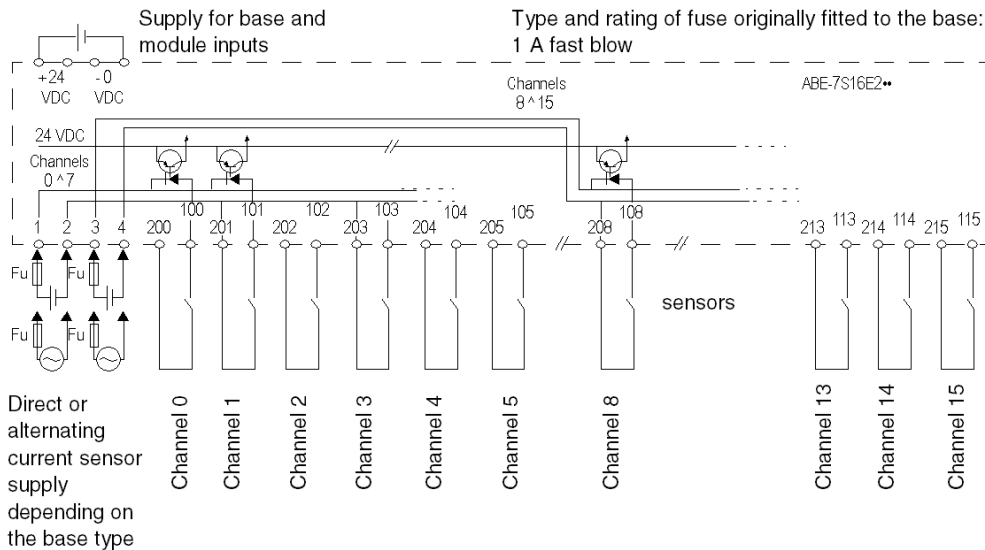

Fu Fuse rating according to the load.

NOTE: Input protection by 2 A fast-blow fuse.

Characteristics of non removable static relay input adaptation bases ABE-7S16E2B1/E2E1/E2E0/E2F0/E2M0

At a Glance

This section describes the general characteristics of bases **TELEFAST 2 ABE-7S16E2B1/E2E1/E2E0/E2F0/E2M0**.

General characteristics

This table describes the general characteristics of bases **ABE-7S16E2B1/E2E1/E2E0/E2F0/E2M0**

Base types		ABE-7S16E2B1	ABE-7S16E2E1	ABE-7S16E2E0	ABE-7S16E2F0	ABE-7S16E2M0	
Channel number		16					
Command circuit characteristics (1)							
Nominal values		Voltage	24 VDC	48 VDC	48 VAC	110..130 VAC	230..240 VAC
		Current	12 mA	13 mA	12 mA	8.3 mA	8 mA
		Speed	-	-	50/60 Hz		
Input threshold	In state 1	Voltage	≥ 13.7 V	≥ 30 V	≥ 32 V	≥ 79 V	≥ 164 V
		Current	≥ 5 mA	≥ 6 mA	≥ 5 mA		≥ 4.5 mA
	In state 0	Voltage	≤ 5 V	≤ 10 V		≤ 30 V	≤ 40 V
		Current	≤ 2 mA		≤ 1.5 mA	≤ 2 mA	
	Speed	-	-	47/63 Hz			
	Sensor supply (ripple included)	19..30 V	38,4..60 V	38,4..53 V	96..143 V	184..264 V	
Compliance with IEC 1131-2		type 1	type 2	type 1			
Response time	State 0 to 1	0.05 ms		20 ms			
	State 1 to 0	0.4ms		20 ms			
Maximum switching speed		1000 Hz		25 Hz			
Voltage assigned to insulation	Input/output	300 V					
Voltage assigned to shock resistance (1.2/50)	Input/output	2.5 kV					
Key							
(1)	Operating piece inputs.						

31.18 TELEFAST 2 ABE-7S16S2B0/S2B2 connection bases

Aim of this section

This section introduces the **TELEFAST 2 ABE-7S16S2B0/S2B2** connection bases.

What's in this Section?

This section contains the following topics:

Topic	Page
Actuator connections on ABE-7S16S2B0/S2B2 static output adaptation bases	304
Characteristics of static output adaptation bases ABE-7S16S2B0/S2B2	305

Actuator connections on ABE-7S16S2B0/S2B2 static output adaptation bases

At a Glance

This is an overview of actuator connections on the **TELEFAST 2 ABE-7S16S2B0/S2B2** bases, 16 static outputs, 24 VDC, 0.5 A.

Illustration

Description of the connection terminal blocks.

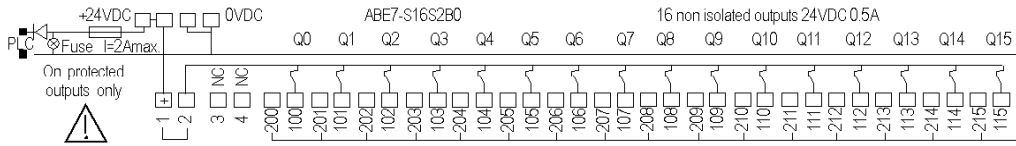

Illustration

Output connection functions.

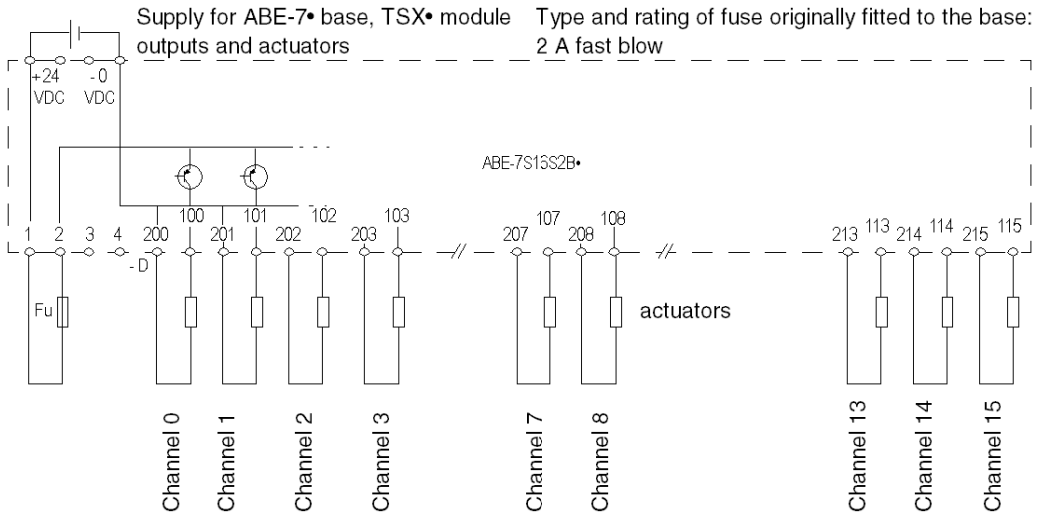

Fu Fuse rating according to the load.

Characteristics of static output adaptation bases ABE-7S16S2B0/S2B2

At a Glance

This section describes the general characteristics of bases **TELEFAST 2 ABE-7S16S2B0/S2B2**.

General characteristics

This table describes the general characteristics of bases **ABE-7S16S2B0/S2B2**

Base types		ABE-7S16S2B0	ABE-7S16S2B2
Channel number		16	
Output circuit characteristics			
Direct current load	Resistive, load DC12	Voltage	24 VDC
		Current	0.5 A
	Inductive, load DC13	Voltage	24 VDC
		Current	0.25 A
Filament lamp		10 W	
Thresholds		Voltage	19..30 VDC
Leakage current at state 0		<= 0.3 mA	
Breakdown voltage at state 1		<= 0.6 V	
Minimum current through channel		1 mA	
Response time		State 0 to 1	0,1 ms
		State 1 to 0	0.02 ms
Built-in protection measures	Against overloads and short-circuits		Yes by current limiter and disjunctioner Id >0.75 A.
	Against inductive voltage overflow		Yes by integrated breakdown diode.
	Against polarity inversions		Yes by suppressor
Switching frequency on inductive load		< 0.6 LI ²	
Error detection report		Yes	No
Voltage assigned to insulation		Input/output	300 V
Voltage assigned to shock resistance (1.2/50)		Input/output	2.5 kV

31.19 TELEFAST 2 ABE-7S08S2B1 connection base

Aim of this section

This section describes the connection base **TELEFAST 2 ABE-7S08S2B1**.

What's in this Section?

This section contains the following topics:

Topic	Page
Actuator connections on ABE-7S08S2B1 static output adaptation base	307
Characteristics of ABE-7S08S2B1 static output adaptation bases	308

Actuator connections on ABE-7S08S2B1 static output adaptation base

At a Glance

This is an overview of the actuator connections on the **TELEFAST 2 ABE-7S08S2B1** base, 8 static outputs, 24 VDC, 2 A.

Illustration

Description of the connection terminal blocks.

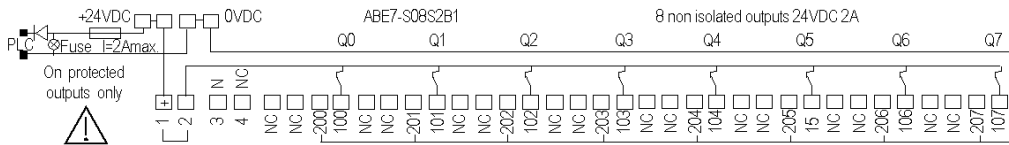

Illustration

Output connection functions.

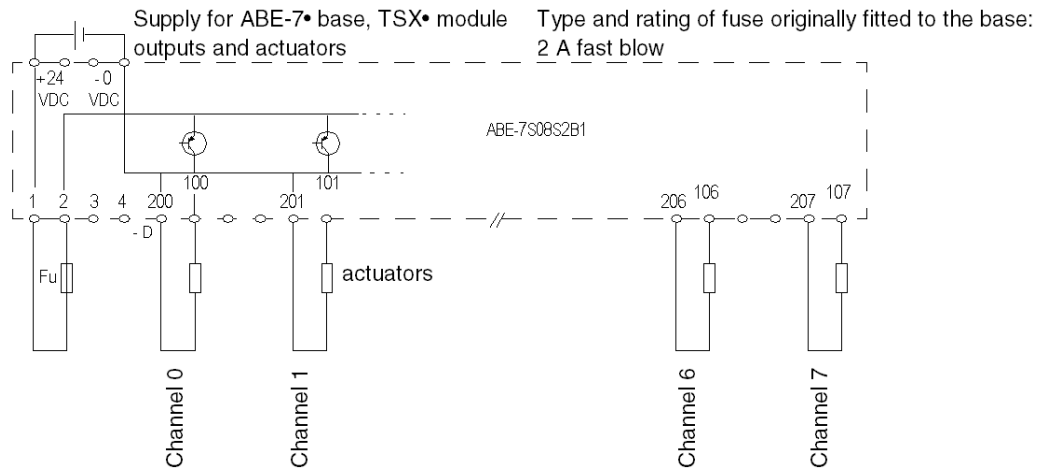

Fu Fuse rating according to the load.

NOTE: Do not connect filament lamps.

Characteristics of ABE-7S08S2B1 static output adaptation bases

At a Glance

This section describes the general characteristics of **TELEFAST 2 ABE-7S08S2B1** base.

General characteristics

This table describes the general characteristics of **ABE-7S08S2B1** base.

Base type		ABE-7S08S2B1	
Channel number		8	
Output circuit characteristics			
Direct current load	Resistive, load DC12	Voltage	24 VDC
		Current	2 A (1)
	Inductive, load DC13	Voltage	24 VDC
		Current	0.5 A (1)
Filament lamp		no	
Thresholds		Voltage	19..30 VDC
Leakage current at state 0		<= 0.5 mA	
Breakdown voltage at state 1		<= 0.5 V	
Minimum current through channel		1 mA	
Response time		State 0 to 1	0.1 ms
		State 1 to 0	0.02 ms
Built-in protection measures	Against overloads and short-circuits		Yes by current limiter and disjunctioner Id >2.6 A.
	Against inductive voltage overflow		Yes by integrated breakdown diode.
	Against polarity inversions		Yes by suppressor
Switching frequency on inductive load		< 0.5 LI ²	
Error detection report		Yes	
Voltage assigned to insulation		Input/output	300 V
Voltage assigned to shock resistance (1.2/50)		Input/output	2.5 kV
Key			
(1)	1 channel out of 2 alternating between 50 °C and +60 °C		

31.20 TELEFAST 2 ABE-7S08S2B0 connection base

Aim of this section

This section describes the **TELEFAST 2 ABE-7S08S2B0** connection base.

What's in this Section?

This section contains the following topics:

Topic	Page
Actuator connections on the ABE-7S08S2B0 static output adaptation base	310
Characteristics of the ABE-7S08S2B0 static output adaptation bases	311

Actuator connections on the ABE-7S08S2B0 static output adaptation base

At a Glance

This is an overview of the actuator connections on TELEFAST 2 ABE-7S08S2B0 bases, 8 static outputs, 24 VDC, 0.5 A.

Illustration

Description of the connection terminal blocks.

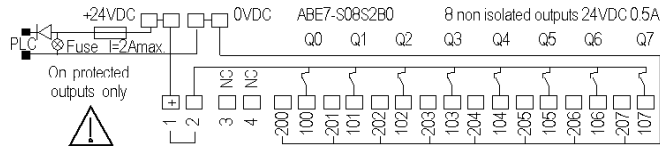

Illustration

Output connection functions.

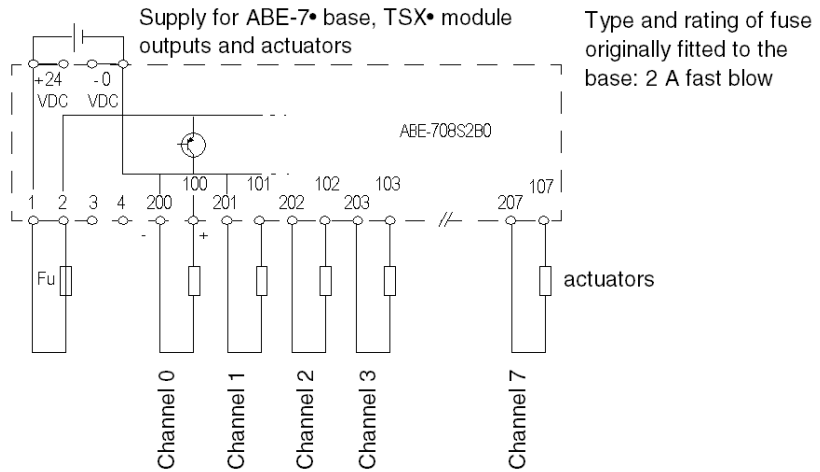

Fu Fuse rating according to the load.

Characteristics of the ABE-7S08S2B0 static output adaptation bases

At a Glance

This section describes the general characteristics of the **TELEFAST 2 ABE-7S08S2B0** base.

General characteristics

This table describes the general characteristics of the **ABE-7S08S2B0** base.

Base type		ABE-7S08S2B0	
Channel number		8	
Output circuit characteristics			
Direct current load	Resistive, load DC12	Voltage	24 VDC
		Current	0.5 A
	Inductive, load DC13	Voltage	24 VDC
		Current	0.25 A
	Filament lamp		10 W
Thresholds		Voltage	19..30 VDC
Leakage current at state 0		<= 0.3 mA	
Breakdown voltage at state 1		<= 0.6 V	
Minimum current through channel		1 mA	
Response time		State 0 to 1	0.1 ms
		State 1 to 0	0.02 ms
Built-in protection measures	Against overloads and short-circuits		Yes by current limiter and circuit breaker $I_d > 0.75$ A.
	Against inductive voltage overflow		Yes by integrated breakdown diode.
	Against polarity inversions		Yes by suppressor
Switching frequency on inductive load		< $0.6 L I^2$	
Error detection report		Yes	
Voltage assigned to insulation		Input/output	300 V
Voltage assigned to shock resistance (1.2/50)		Input/output	2.5 kV

31.21 TELEFAST 2 ABE-7R16T210/P16T210 connection bases

Actuator connections on ABE-7R16T210/P16T210 electromechanical or static output relay bases (size 10 mm)

At a Glance

This is a description of the actuator connections on:

- **TELEFAST 2 ABE-7R16T210** base, 16 relay outputs, 1 F, potential free contact, with electromagnetic relay;
- **TELEFAST 2 ABE-7P16T210** base, 16 relay outputs, 1 F, potential free contact, relay not provided.

Illustration

Description of the connection terminal blocks.

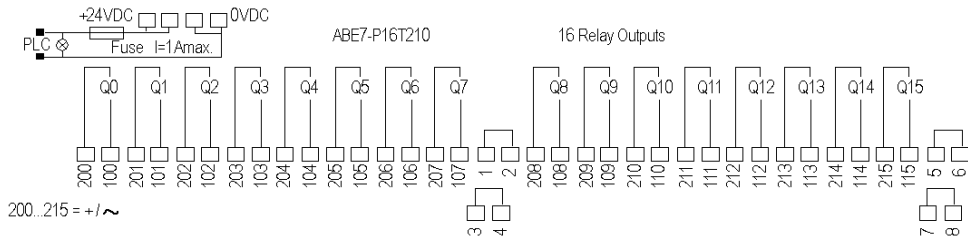

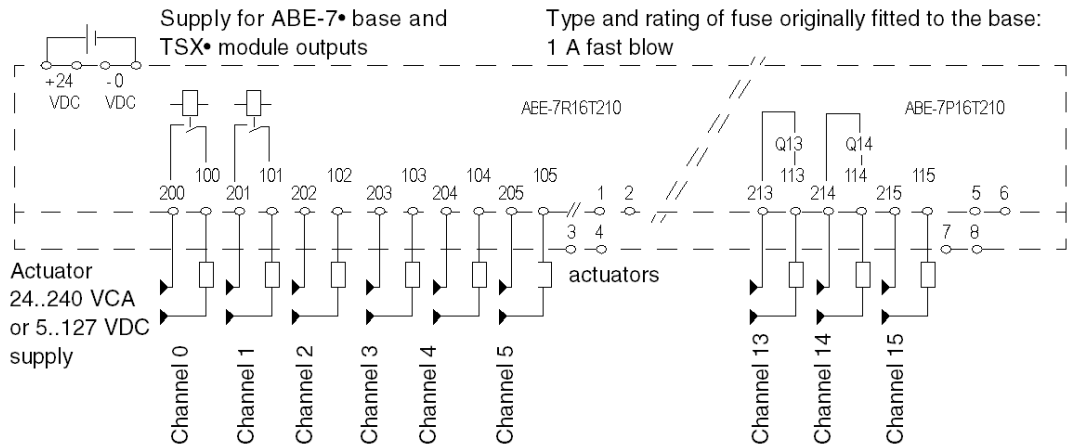
Illustration**Output connection functions**

31.22 TELEFAST 2 ABE-7R16T212/P16T212 connection bases

Actuator links on ABE-7R16T212/P16T212 electromechanical or static output relay bases (size 10 mm)

At a Glance

This is a description of the actuator connections on:

- **TELEFAST 2 ABE-7R16T212** base, 16 relay outputs, 1 F, with distribution of the 2 polarities by 8 channel group, with electromagnetic relay;
- **TELEFAST 2 ABE-7P16T212** base, 16 relay outputs, 1 F, distribution of the 2 polarities by 8 channel group, relay not provided.

Illustration

Description of the connection terminal blocks.

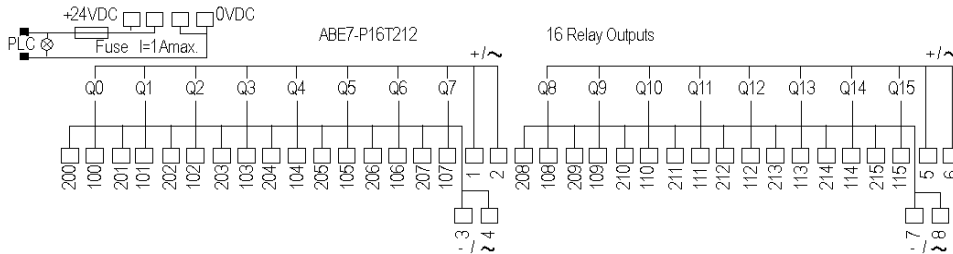

Illustration

Output connection functions.

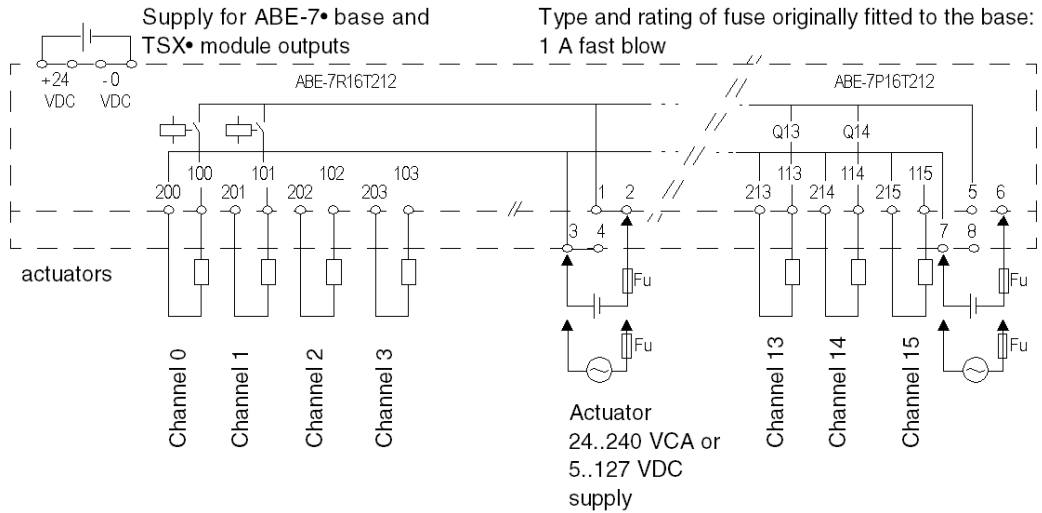
**Fu** Fuse rating according to the load.**NOTE:** Protection of relay contacts:

- a protection circuit must be mounted onto the terminals of each actuator:
 - RC or MOV circuit in the case of alternating current;
 - discharge diode for direct current.

31.23 TELEFAST 2 ABE-7R16T230 connection base

Actuator connections on ABE-7R16T230 electromechanical output relay bases (size 10 mm)

At a Glance

This is an overview of the actuator connections on the **TELEFAST 2 ABE-7R16T230** base, with 1 OF electromagnetic relay, potential free contact.

Illustration

Description of the connection terminal blocks.

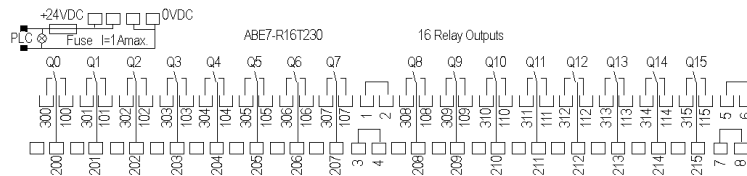

Illustration

Output connection functions.

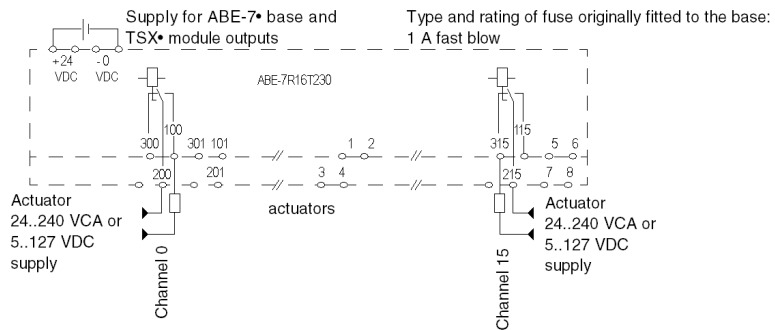

NOTE: Provide one protection fuse per actuator or per group if fed from the same voltage.

Protection of relay contacts:

- a protection circuit must be mounted onto the terminals of each actuator:
 - RC or MOV circuit in the case of alternating current;
 - discharge diode for direct current.

31.24 TELEFAST 2 ABE-7R16T231 connection base

Actuator connections on ABE-7R16T231 electromechanical output relay base (size 10 mm)

At a Glance

This is an overview of the actuator connections on base **TELEFAST 2 ABE-7R16T231**, with 1 OF electromechanical relay, distribution of a common per group of 8 channels.

Illustration

Description of the connection terminal blocks.

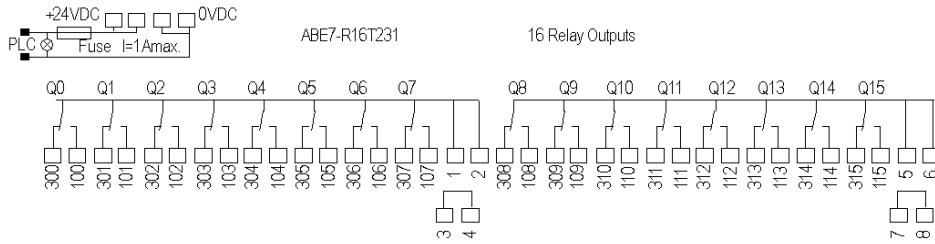

Illustration

Output connection functions.

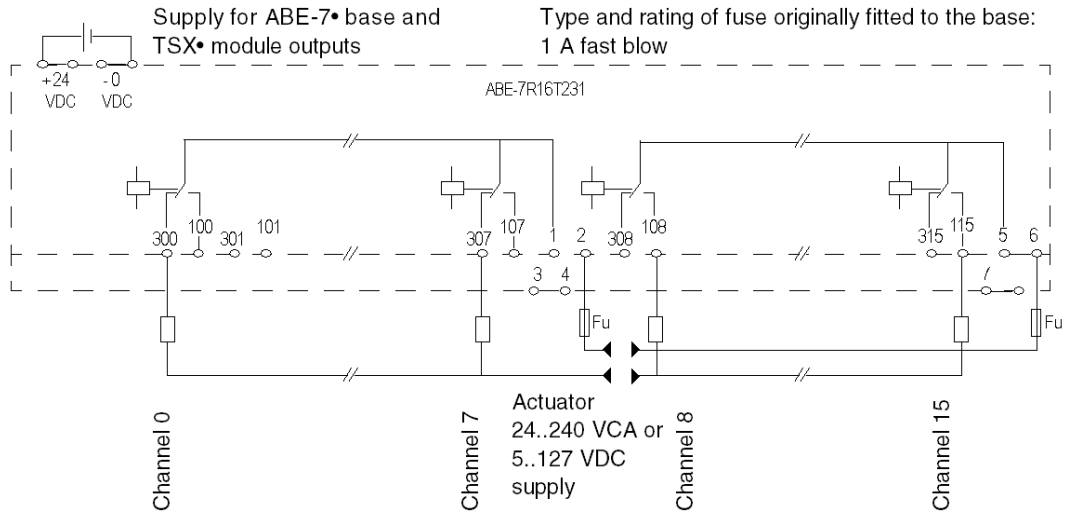
**Fu** Fuse rating according to the load.**NOTE:** Protection of relay contacts:

- a protection circuit must be mounted onto the terminals of each actuator:
 - RC or MOV circuit in the case of alternating current;
 - discharge diode for direct current.

31.25 TELEFAST 2 ABE-7P16T214 connection base

Actuator connections on ABE-7P16T214 electromechanical or static output relay bases (size 10 mm)

At a Glance

This is an overview of the actuator connections on the **TELEFAST 2 ABE-7P16T214** base, 16 relay outputs, 1 F, potential free contact, 1 fuse per channel, relay not provided.

Illustration

Description of the connection terminal blocks.



Illustration

Output connection functions.

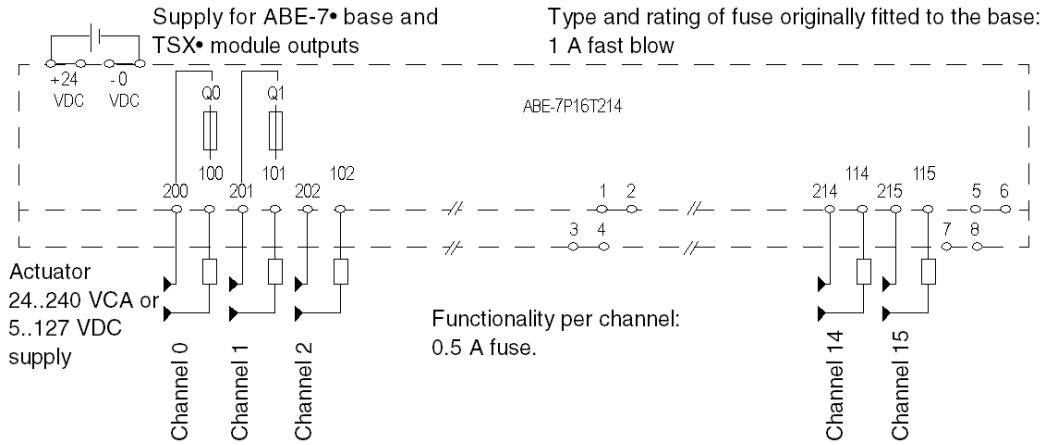

NOTE: Provide one protection fuse per actuator or per group if fed from the same voltage.

Protection of relay contacts:

- a protection circuit must be mounted onto the terminals of each actuator:
 - RC or MOV circuit in the case of alternating current;
 - discharge diode for direct current.

31.26 TELEFAST 2 ABE-7P16T215 connection base

Actuator connections on ABE-7P16T215 electromechanical or static output relay bases (size 10 mm)

At a Glance

This is an overview of the actuator connections on the **TELEFAST 2 ABE-7P16T215** base, 16 relay outputs, 1 F, distribution of 2 polarities per group of 8 channels, 1 fuse per channel, relay not provided.

Illustration

Description of the connection terminal blocks.

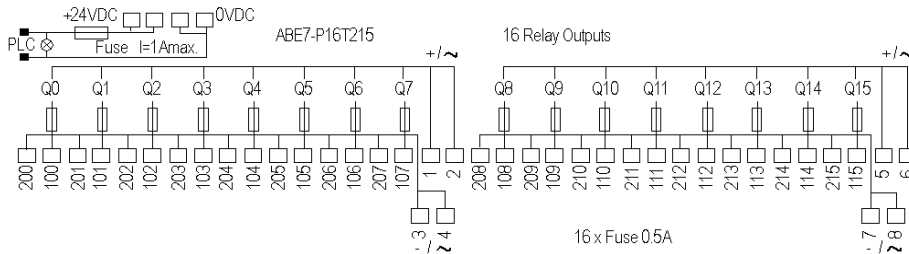

Illustration

Output connection functions.

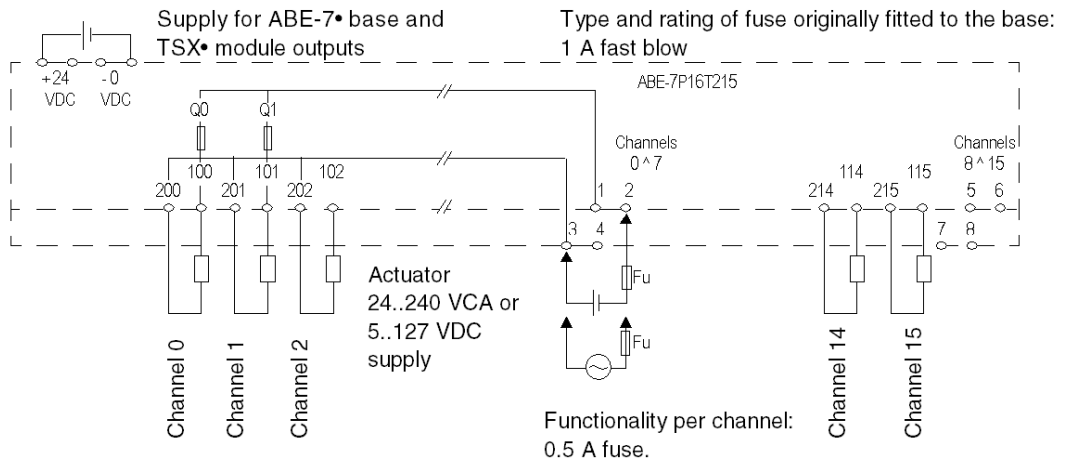
**Fu** Fuse rating according to the load.**NOTE:** Protection of relay contacts:

- a protection circuit must be mounted onto the terminals of each actuator:
 - RC or MOV circuit in the case of alternating current;
 - discharge diode for direct current.

31.27 TELEFAST 2 ABE-7R16T330/P16T330 connection bases

Actuator connections on ABE-7R16T330/P16T330 electromechanical output relay bases (size 12.5 mm)

At a Glance

This is a description of the actuator connections on:

- the **TELEFAST 2 ABE-7R16T330** bases, 16 relay outputs, potential free contact, with electromagnetic relay;
- the **TELEFAST 2 ABE-7P16T330** bases, 16 relay outputs, potential free contact, relay not provided.

Illustration

Description of the connection terminal blocks.

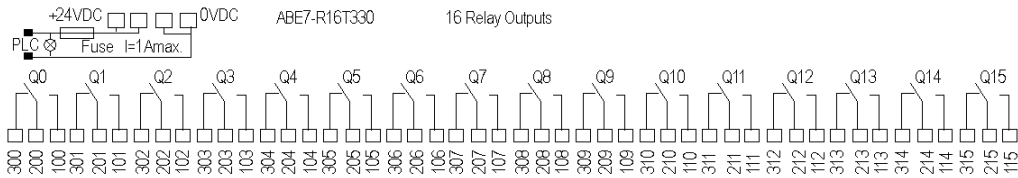

ABE-7R16T330/P16T330 16 output relays, 1 OF, potential free contact, ABE-7R16T330 with electromagnetic relays, ABE-7P16T330 relays not provided.

Illustration

Output connection functions.

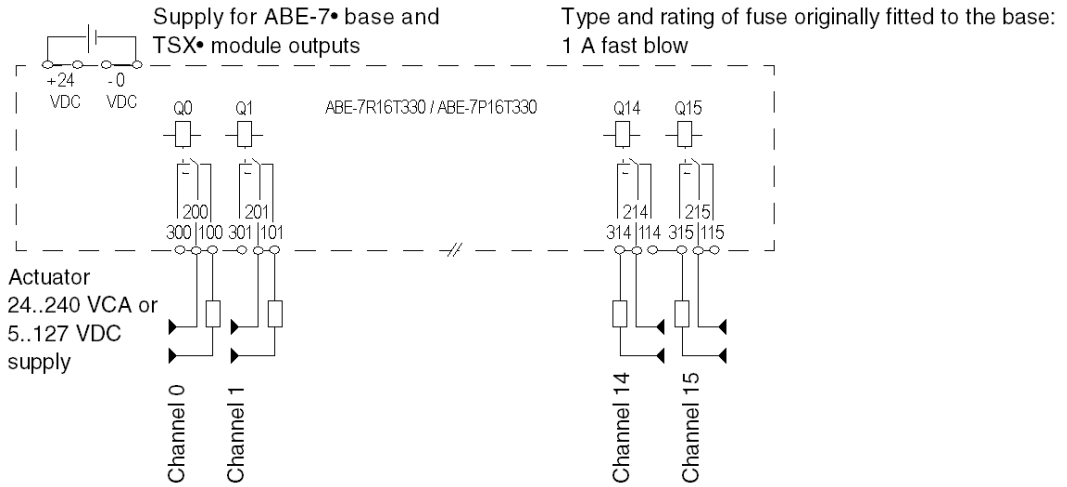

NOTE: Provide one protection fuse per actuator or per group if fed from the same voltage.

Protection of relay contacts:

- a protection circuit must be mounted onto the terminals of each actuator:
 - RC or MOV circuit in the case of alternating current;
 - discharge diode for direct current.

31.28 TELEFAST 2 ABE-7R16T332/P16T332 connection bases

Actuator connections on ABE-7R16T332/P16T332 electromechanical output relay bases (size 12.5 mm)

At a Glance

This is a description of the actuator connections on:

- the **TELEFAST 2 ABE-7R16T332** base, 16 relay outputs, 1 OF, distribution of the 2 polarities by 4 channel group, with electromagnetic relay;
- the **TELEFAST 2 ABE-7P16T332** base, 16 relay outputs, 1 OF, distribution of the 2 polarities by 4 channel group, relays not provided.

Illustration

Description of the connection terminal blocks.

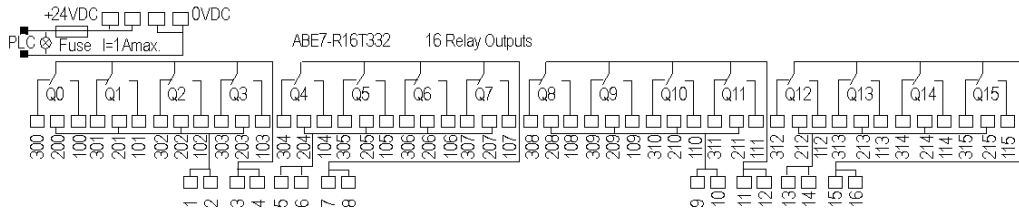

Illustration

Output connection functions.

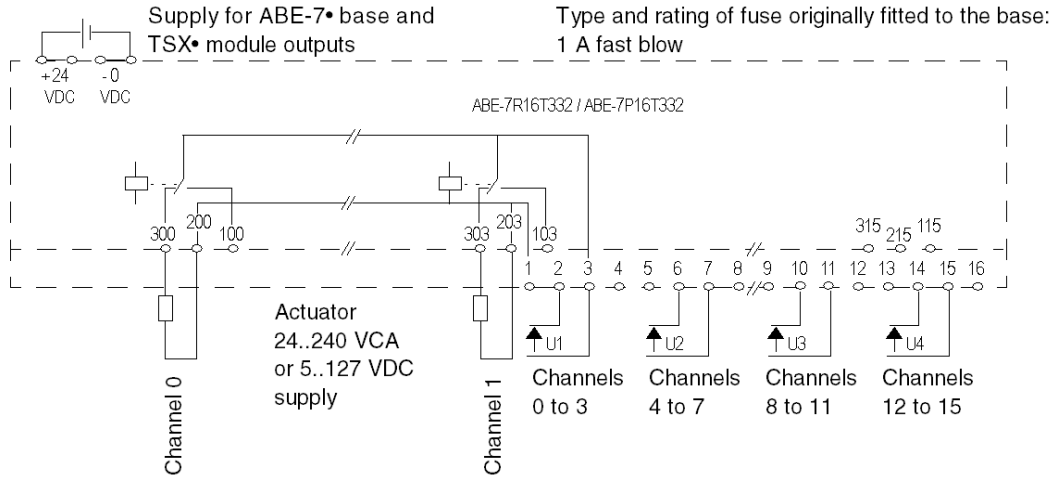

NOTE: Provide one protection fuse per actuator or per group if fed from the same voltage.

Protection of relay contacts:

- a protection circuit must be mounted onto the terminals of each actuator:
 - RC or MOV circuit in the case of alternating current;
 - discharge diode for direct current.

31.29 TELEFAST 2 ABE-7R16T370 connection base

Actuator connections on ABE-7R16T370 electromechanical output relay bases (size 12.5 mm)

At a Glance

This is an overview of the actuator connections on the **TELEFAST 2 ABE-7R16T370** base, 16 relay outputs, 2 OF, potential free contact.

Illustration

Description of the connection terminal blocks.

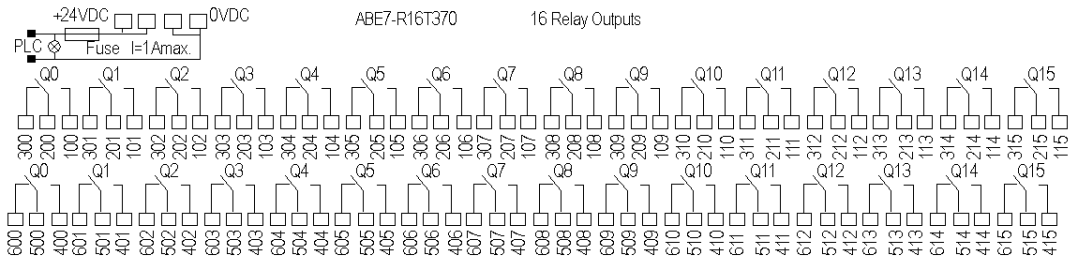

Illustration

Output connection functions.

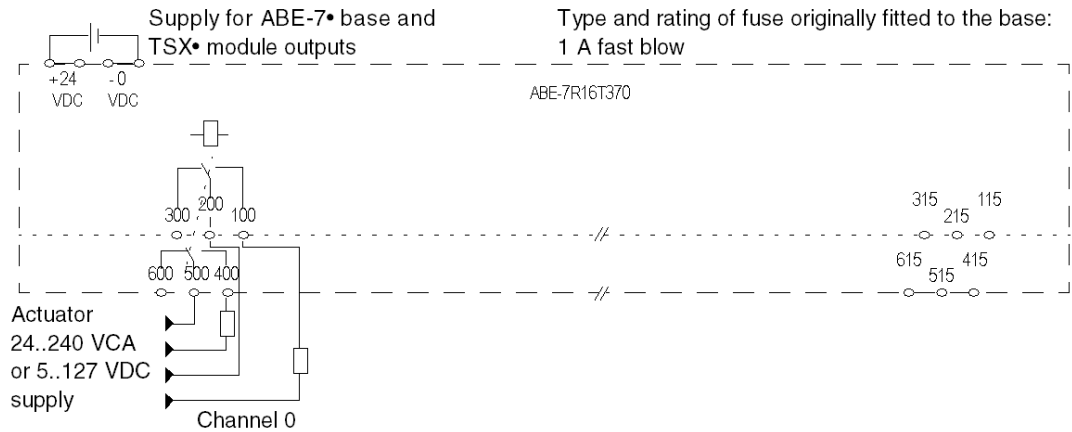

NOTE: Provide one protection fuse per actuator or per group if fed from the same voltage.

Protection of relay contacts:

- a protection circuit must be mounted onto the terminals of each actuator:
 - RC or MOV circuit in the case of alternating current;
 - discharge diode for direct current.

31.30 TELEFAST 2 ABE-7P16T334 connection base

Actuator connections on ABE-7P16T334 electromechanical or static output relay bases (size 12.5 mm)

At a Glance

This is an overview of the actuator connections on the **TELEFAST 2 ABE-7P16T334** base, 16 relay outputs, 1 OF, potential free contact, relays not provided.

Illustration

Description of the connection terminal blocks.

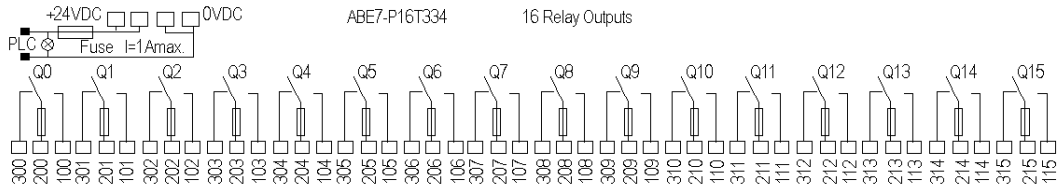

Illustration

Output connection functions.

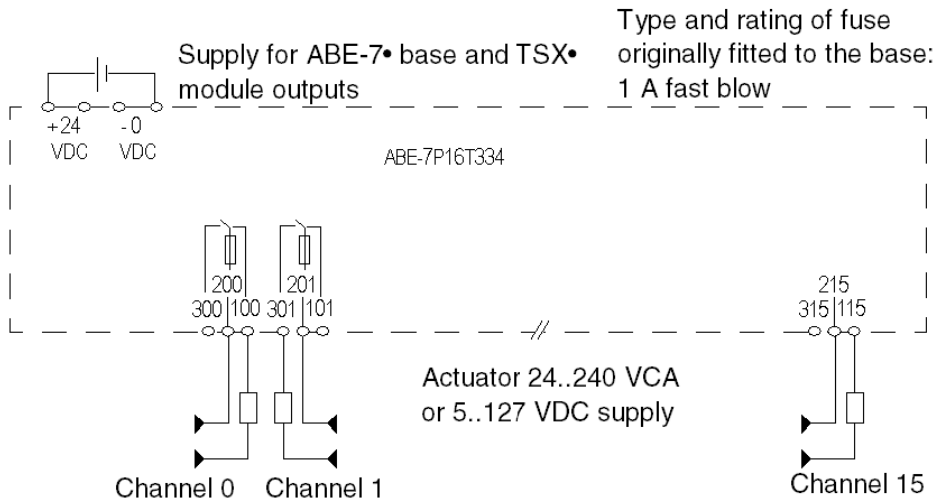

Functionality per channel:
0.5 A fuse.

NOTE: Provide one protection fuse per actuator or per group if fed from the same voltage.

Protection of relay contacts:

- a protection circuit must be mounted onto the terminals of each actuator:
 - RC or MOV circuit in the case of alternating current;
 - discharge diode for direct current.

31.31 TELEFAST 2 ABE-7P16T318 connection base

Actuator connections on ABE-7P16T318 electromechanical or static output relay base (width 12.5 mm)

At a Glance

This is an overview of the actuator connections on the **TELEFAST 2 ABE-7P16T318** base, 16 relay outputs, 1 OF, distribution of the 2 polarities per group of 4 channels, 1 fuse and 1 isolator per channel, relays not provided.

Illustration

Description of the connection terminal blocks.

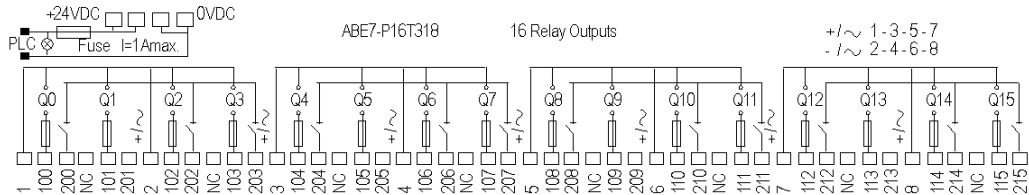

Illustration

Output connection functions.

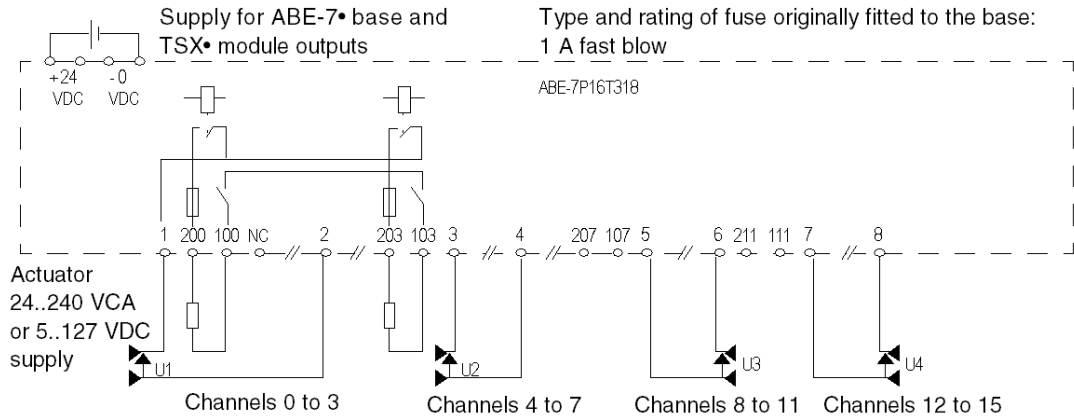

Functionality per channel:

- 2 A fuse,
- isolation of common

NOTE: Provide a protection fuse on the actuator supply.

Protection of relay contacts:

- a protection circuit must be mounted onto the terminals of each actuator:
 - RC or MOV circuit in the case of alternating current;
 - discharge diode for direct current.

31.32 TELEFAST 2 ABE-7P16F310 connection base

Sensor connections on ABE-7P16F310 static input relay base (width 12.5 mm)

At a Glance

This is an overview of the actuator connections on the **TELEFAST 2 ABE-7P16F310** base, 16 relay outputs, potential free contact, relays not provided.

Illustration

Description of the connection terminal blocks.

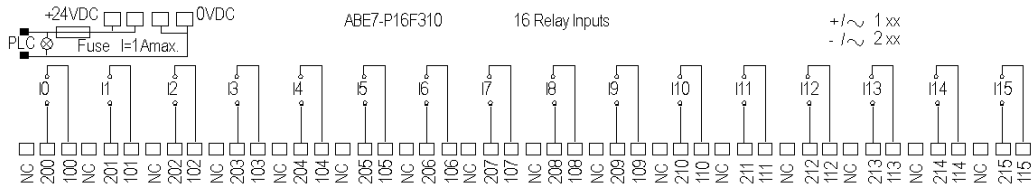

Illustration

Output connection functions.

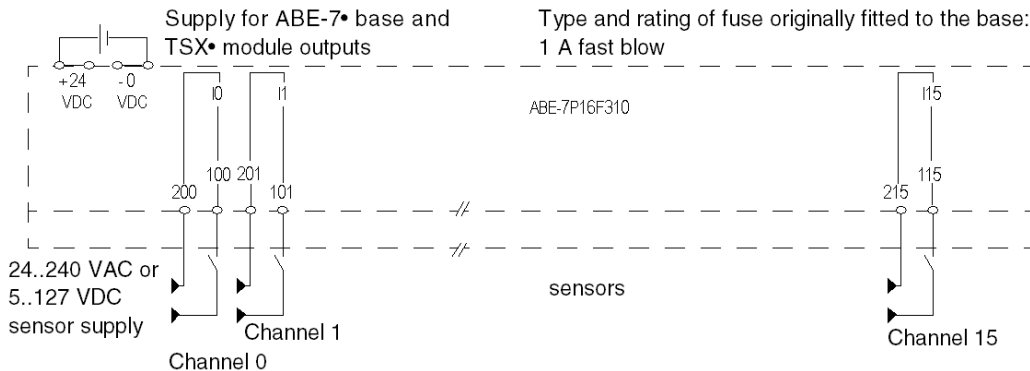

NOTE: Provide one protection fuse per group of sensors if supplied from the same voltage.

31.33 TELEFAST 2 ABE-7P16F312 connection base

Sensor connections on ABE-7P16F312 static input relay bases (size 12.5 mm)

At a Glance

This is an overview of the actuator connections on the **TELEFAST 2 ABE-7P16F312** base, 16 relay outputs, distribution of the 2 polarities per 8 channel group, relays not provided.

Illustration

Description of the connection terminal blocks.

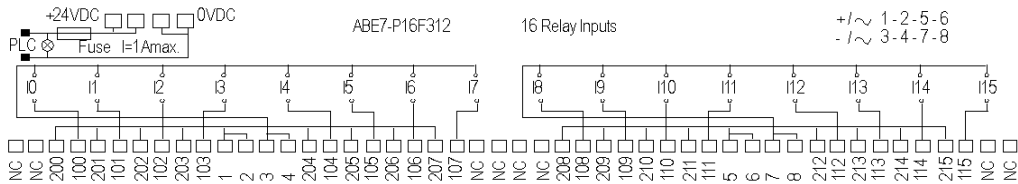

Illustration

Output connection functions.

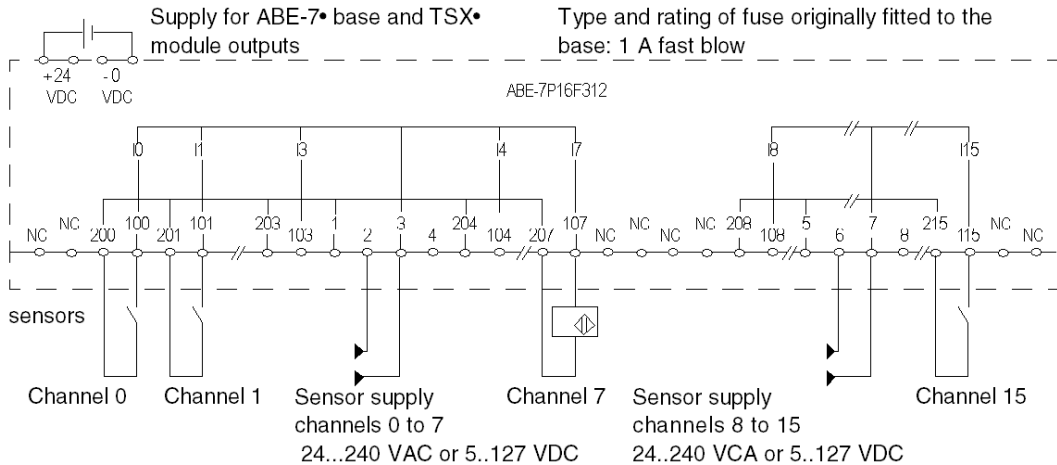

NOTE: Plan for a protection fuse for the sensor supply.

31.34 TELEFAST 2 Connection Base Accessories

Aim of this Section

This section introduces the TELEFAST 2 connection bases' range of accessories.

What's in this Section?

This section contains the following topics:

Topic	Page
TELEFAST 2 Connection Base Accessories Catalog	336
Association Table for the Relays on ABE-7R16Txxx, ABE-7P16Txxx and ABE-7P16Fxxx Bases	338
Characteristics of the Removable ABR-7xxx Electromechanical Output Relays	340
Characteristics of the Removable ABS-7Exx Static input Relays	341
Characteristics of the Removable ABS-7Sxx Static Output Relays	342

TELEFAST 2 Connection Base Accessories Catalog

At a Glance

This is an overview of the TELEFAST 2 connection base accessories catalog for discrete I/O modules.

Catalog

The table below shows the TELEFAST 2 connection base accessories catalog.

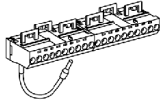
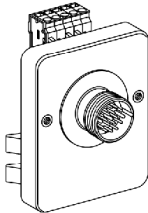
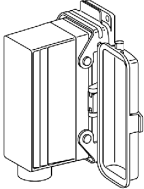
Product reference	Illustration	Description
Additional shunt terminal block		
ABE-7BV10		Terminal block fitted with 10 screw terminal blocks
ABE-7BV20		Terminal block fitted with 20 screw terminal blocks
Adapter base		
ABE-7ACC02		Enables the connection of 16 channels in 2 x 8-channel groups
Mounting kit		
ABE-7ACC01		Enables the bases to be mounted on monoblock mounting plates
Sealed cable lead-through		
ABE-7ACC84		Allows transit through cabinets without cutting the cables
Transit through cabinet		
ABE-7ACC83		40-pin connectors for 8/12 channels -> M23 cylindrical connector
ABE-7ACC82		40-pin connectors for 16 channels -> M23 cylindrical connector
ABE-7ACC80		40-pin connectors for 32 channels -> HARTING type connector

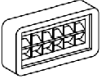
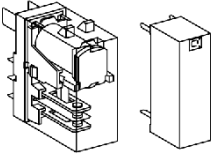
Product reference	Illustration	Description
ABE-7ACC81		Plug-in connector for ABE-7ACC80
Removable continuity module		
ABE-7ACC20		Width 10 mm
ABE-7ACC21		Width 12.5 mm
Customer identification label marking software		
ABE-7LOGV10	-	-
5 x 20 quick-blow glass fuse		
ABE-7FU012		0.125 A
ABE-7FU050		0.5 A
ABE-7FU100		1 A
ABE-7FU200		2 A
ABE-7FU630		6.3 A
Adhesive marker holder		
AR1-SB3		For AB1-R. / AB1-G type markers
Relays for ABE-7R16T***, ABE-7P16T*** and ABE-7P16F*** bases		
ABR-7S*** (1)	ABE-7S3** and ABE-7S2**	Output electromechanical relay (4)
ABS-7S*** (2)		Output static relay (4)
ABS-7E*** (3)		Input static relay (4)

- (1) For electrical characteristics, see *Characteristics of the Removable ABR-7xxx Electromechanical Output Relays, page 340.*
- (2) For electrical characteristics, see *Characteristics of the Removable ABS-7Sxx Static Output Relays, page 342.*
- (3) For electrical characteristics, see *Characteristics of the Removable ABS-7Exx Static input Relays, page 341.*
- (4) Contingency table of relays for bases, see *Association Table for the Relays on ABE-7R16Txxx, ABE-7P16Txxx and ABE-7P16Fxxx Bases, page 338.*

Association Table for the Relays on ABE-7R16Txxx, ABE-7P16Txxx and ABE-7P16Fxxx Bases

At a Glance

The table for comparison between the TELEFAST 2 **ABE-7R16T*****, **ABE-7P16T***** and **ABE-7P16F***** link bases and the electromagnetic or static relays is described here.

Compatibility Table

The table below shows the association possibilities for the electromagnetic or static relays on the TELEFAST 2 bases.

Bases ABE-7**		equipped with electromagnetic relays				not equipped with relays			
		R16T21•	R16T23•	R16T33•	R16T370	P16T21•	P16T33•	P16T318	P16F31•
Electromagnetic relays from ABR-7*** output									
10 mm	S21 1F	X	-	-	-	X	-	-	-
	S23 1OF	X (1)	X	-	-	-	-	-	-
12.5 mm	S33 1OF	-	-	X	-	-	X	X	-
	S37 2OF	-	-	-	X	-	-	-	-
Static relays from ABS-S** output									
10 mm	C2E	X (1)	-	-	-	X	-	-	-
	A2M	X (1)	-	-	-	X	-	-	-
12.5 mm	C3BA	-	-	X (1)	-	-	X (2)	X	-
	C3E	-	-	X (1)	-	-	X	X	-
	A3M	-	-	X (1)	-	-	X	X	-
Static relays from ABS-7E** input									
12.5 mm	C3AL	-	-	-	-	-	-	-	X
	C3B2	-	-	-	-	-	-	-	X
	C3E2	-	-	-	-	-	-	-	X
	A3E5	-	-	-	-	-	-	-	X
	A3F5	-	-	-	-	-	-	-	X
	A3F6	-	-	-	-	-	-	-	X
	A3M5	-	-	-	-	-	-	-	X
	A3M6	-	-	-	-	-	-	-	X

Bases ABE-7**		equipped with electromagnetic relays				not equipped with relays			
		R16T21*	R16T23*	R16T33*	R16T370	P16T21*	P16T33*	P16T318	P16F31*
ABE-7*** continuity block									
10 mm	ACC20	X	-	-	-	X	-	-	-
12.5 mm	ACC21	-	-	X	-	-	X	X	-
(1) relays can be in line									
(2) except on ABE-7P16T334									

X compatible
 - not compatible

Characteristics of the Removable ABR-7xxx Electromechanical Output Relays

At a Glance

The general characteristics of the removable ABR-7*** electromechanical output relays for TELEFAST 2 bases are described in this section.

General Characteristics

This table shows the general characteristics of the ABR-7*** relays.

ABR-7*** reference		S21	S23	S33	S37	
Relay width		10 mm		12.5 mm		
Characteristics of the contacts						
Composition of the contacts		1 F	1 OF		2 OF	
Max. operating voltage according to IEC 947-5-1	Alternating	250 V		264 V		
	Direct	125 V				
Thermal current		4 A		5 A		
Frequency of current used		50/60 Hz				
Alternating current load	Resistive, load AC12	Voltage	230 VAC			
		Current	1.5 A	1.2 A	3 A	2.5 A
	Inductive load AC15	Voltage	230 VAC			
		Current	0.9 A	0.7 A	1.7 A	1.3 A
Direct current load	Resistive, load DC12	Voltage	24 VDC			
		Current	1.5 A	1.2 A	3 A	2.5 A
	Inductive load DC13, L/R = 10 ms	Voltage	24 VDC			
		Current	0.6 A	0.45 A	1.4 A	1 A
Minimum switching		Current	10 mA		100 mA	
		Voltage	5 V			
Response time		State 0 to 1	10 ms		13 ms	15 ms
		State 1 to 0	5 ms		13 ms	20 ms
Maximum speed of function loading		0.5 Hz				
Voltage assigned insulation		Coil/contact	300 V			
Voltage assigned shock resistance (1.2/50)		Coil/contact	2.5 kV			

(1) for 0.5×10^6 maneuvers

Characteristics of the Removable ABS-7Exx Static Input Relays

At a Glance

The general characteristics of the removable ABS-7E** static input relays for TELEFAST 2 bases are described in this section.

General Characteristics

This table shows the general characteristics of the ABS-7E** relays.

ABS-7E** reference		C3A1	C3B2	C3E2	A3E5	A3F5	A3M5
Relay width		12.5 mm					
Command characteristics							
Assigned operating voltage (Us)	Direct	5 V	24 V	48 V	-		
	Alternating	-			48 V	110..130 V	230..240 V
Max. operating voltage (including ripple)		6 V	30 V	60 V	53 V	143 V	264 V
Max. current at Us		13.6 mA	15 mA		12 mA	8.3 mA	8 mA
State 1 guaranteed	Voltage	3.75 V	11 V	30 V	32 V	79 V	164 V
	Current	4.5 mA	6 mA		5 mA		4.5 mA
State 0 guaranteed	Voltage	2 V	5 V	10 V		30 V	40 V
	Current	0.09 mA	2 mA		1.5 mA	2 mA	
Maximum switching frequency (cyclic report 50%)		1000 Hz			25 Hz		
Complies with IEC1131-2		-	Type 2		Type 1		
Response time	State 0 to 1	0.05 ms			20 ms		
	State 1 to 0	0.4 ms			20 ms		
Voltage assigned to insulation	Input/output	300 V					
Voltage assigned to shock resistance (1.2/50)	Input/output	2.5 kV					

Characteristics of the Removable ABS-7Sxx Static Output Relays

At a Glance

The general characteristics of the removable ABS-7Sxx static output relays for TELEFAST 2 bases are described in this section.

General Characteristics

This table shows the general characteristics of the ABS-7Sxx relays.

ABS-7Sxx reference			C2E	A2M	C3BA	C3E	A3M
Relay width			10 mm		12.5 mm		
Output circuit characteristics							
Voltage assigned to job		Direct	5..48 V	-	24 V	5..48 V	-
		Alternating	-	24..240 V	-		24..240 V
Max. voltage			57.6 VDC	264 VAC	30 VDC	60 VDC	264 VAC
Alternating current load	Resistive, load AC12	Current	-	0.5 A	-		2 A
	Direct current load	Resistive, load DC12	Current	0.5 A	-	2 A	1.5 A
Direct current load	Inductive load DC13	Current	-	-		0.3 A	-
	Filament lamp load DC6		-			10 W	-
Leakage current at state 0			<= 0.5 mA	<= 2 mA	<= 0.3 mA		<= 2 mA
Breakdown voltage at state 1			<= 1 V	<= 1.1 V	<= 0.3 V	<= 1.3 V	
Minimum current through channel			1 mA	10 mA	1 mA		10 mA
Response time		State 0 to 1	0.1 ms	10 ms	0.1 ms		10 ms
		State 1 to 0	0.6 ms	10 ms	0.02 ms	0.6 ms	10 ms
Switching frequency on inductive load			-		< 0.5 LI ²	-	
Voltage assigned to insulation		Input/output	300 V				
Voltage assigned to shock resistance (1.2/50)		Input/output	2.5 kV				

Implementation of safety modules

32

Overview

This chapter describes implementation of the range of safety modules for Premium PLCs and of the dedicated **TELEFAST 2** pre-formed cabling accessory.

What's in this Chapter?

This chapter contains the following sections:

Section	Topic	Page
32.1	General presentation of the safety modules	344
32.2	Safety functions	348
32.3	General rules for the installation of safety modules	355
32.4	Precautions and general rules for wiring	360
32.5	Connection and wiring examples	365
32.6	Maintenance and diagnostics	379
32.7	TSX PAY 262 module	389
32.8	TSX PAY 282 module	394

32.1 General presentation of the safety modules

Overview

This section provides a general introduction to safety modules.

What's in this Section?

This section contains the following topics:

Topic	Page
General description of safety modules	345
Physical description of the safety modules	346
Catalog of safety modules	347

General description of safety modules

General

The **TSX PAY 2•2** safety modules and their accessories **TSX CPP 301•02** and **TELEFAST 2 ABE-7CPA13** are used to interrupt one or several category 0 safety or emergency stop control circuits (safety components) in complete safety. The entire safety system is compliant with European standards EN 418 for emergency stops and EN 60204-1 for safety circuits.

These modules also comply with safety requirements regarding the electrical monitoring of position switches activated by protection devices.

The **TSX PAY 2•2** safety modules provide:

- A safety system designed to control the emergency stop circuits of machines in complete safety. The modules are equipped with a wired logic safety block for monitoring emergency stops.
- Full diagnostics of the safety system readable from the status of the position switches and push-buttons of the emergency stop input sequence, the reactivation input, the feedback loop, the control of both output circuits, and the safety system power supply status. All this information is sent to the PLC's CPU in the form of 28-bit Discrete inputs.

NOTE: The PLC has no effect on the safety modules, and the safety system section is connected to an external power supply.

Physical description of the safety modules

Introduction

The **TSX PAY 2•2** modules are in standard Premium PLC interface format. They occupy a single slot.

Illustration

The following diagram shows the safety modules:

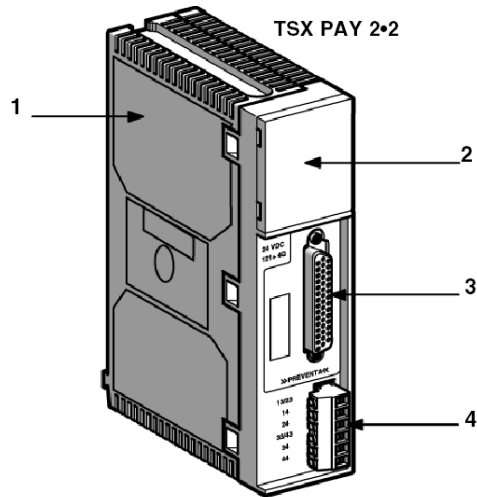

Elements

The following table gives a description of the different elements of the safety modules:

Number	Description
1	IP20 hard casing providing support and protection for the circuit board.
2	Operating mode, fault and safety system display block
3	High Density (HD) 44-pin Sub-D connector for connecting the safety system.
4	Removable screw terminal block for connecting safety outputs

Catalog of safety modules

Catalog

The following table shows the catalog of safety modules.

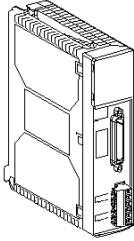
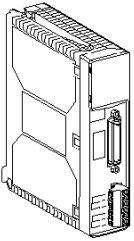
Function	Emergency stop and position switch monitoring	
Target applications	1 to 12 double contact PS / ES PBs. Relay cut-off: 2 safety outputs	1 to 12 double contact PS / ES PBs. Relay cut-off: 4 safety outputs
Illustration	Safety module 	Safety module 
Category	4	
No. of outputs	2 "N/O" (immediate stop)	4 "N/O" (immediate stop)
No. of inputs	12 double or single contacts	
I/O system connection	By HD 44-pin Sub-D connector By 6-pin screw terminal block	
Supply	24 VDC	
Safety system voltage	24 VDC	
Reactivation monitoring	Yes, by strap	
Standards	EN 60204-1, EN 292, EN 418, prEN 1921, BS 2771-1, DIN VDE 0113-1, EN 954, EN 1088, EN 574 type III A, NF C 79-130, NF E 09-053	
Display	28 LEDs + 3 Premium range standard status LEDs	
Input synchronization	Approx. ms (< 1 s, automatic start-up)	
TSX** reference number	PAY 262	PAY 282
Legend:		
ES PB	emergency stop push button	
PS	position switch	
"C"	normally open	

32.2 Safety functions

Overview

This section gives a description of every function for which the safety modules are used. .

What's in this Section?

This section contains the following topics:

Topic	Page
Product user functions	349
Operating modes	350
Functional diagrams	353

Product user functions

General

The **TSX PAY 2•2** modules provide the following functions:

- Monitoring of emergency stop buttons and moving cover position switches for immediate halt (category 0 emergency stop in compliance with EN 418),
- Channel de-synchronization detection (> 400 ms) in automatic start-up mode,
- Cabled safety block independent of Premium PLC operating mode,
- Guaranteed safety functions, whatever the safety system component failure, via:
 - 2 safety output circuits,
 - double contact inputs for ES PB or PS,
- Wiring of a (+) channel of an input x and of the (-) channel to another input (x+12) with a double contact,
- Self-checking and redundant design similar to the PREVENTA XPS-ASF range (cf. component catalog for Telemecanique safety applications),
- Restart control via auxiliary input action: reactivation input,
- Possibility of monitoring the reactivation input by action on falling edge,
- Start-up mode selection using external cabling: manual, automatic or on falling edge,
- Automatic output check by monitoring their status reading in the feedback loop,
- Automatic input channel check by constant comparison of their respective statuses,
- Full safety system diagnostics via:
 - monitoring the ES PB or PS input status readings,
 - monitoring the reactivation input reading,
 - monitoring the feedback loop reading,
 - monitoring the safety output control reading,
 - monitoring the safety system power supply status reading,
 - monitoring the external module supply,
- Possibility to choose whether external supply is monitored or not.

Operating modes

Introduction

The safety function is autonomous in relation to PLC operation.

It does not follow the PLC operating modes.

It is able to shut off power even when the PLC is off, in Stop mode or if the CPU is missing. **It is not a safety PLC.**

The only exchange between the CPU and the module is diagnostic information transferred from the module to the CPU.

The PLC is constantly informed of the status of the safety system via input data. Nevertheless, **the PLC has no control over any output.**

Diagram

The product diagram is shown below:

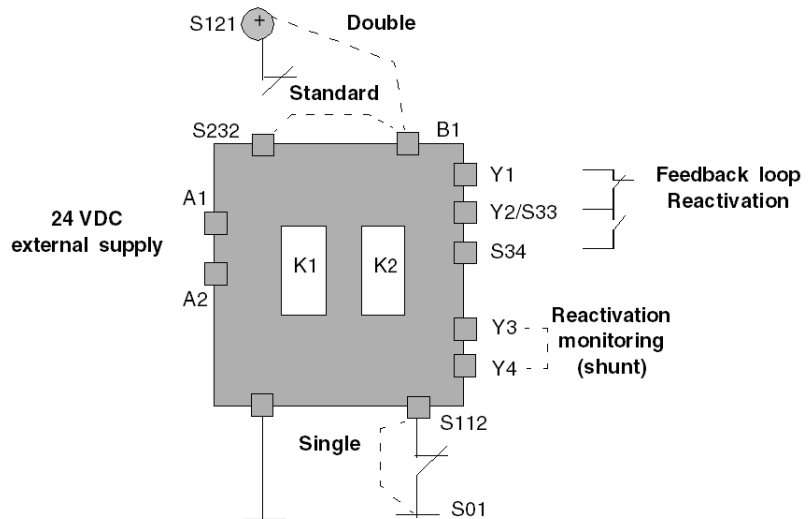

External supply

The 24 VDC supply is cabled between terminals A1 and A2. It must be protected by an external fuse.

Using ES PB and PS single/double contacts

The way in which the B1 terminal is wired makes it possible to choose the type of single or double ES PB:

- When B1 is linked to S121, the module will be wired with double contacts between terminals S121 and S232 for the positive pole, and between terminals S01 and S112 for the negative pole,
- When B1 is linked to S232, the module will be wired with single contacts between terminals S121 and S232 for the positive pole, and with a global shunt between terminals S01 and S112 for the negative pole.

Using ES PB and PS contacts

Pressing one of the emergency stop buttons or a cut in external supply leads directly to the opening of the K1 and K2 safety output circuits,

After unlocking the ES PB or closing the PS of the input sequence, a pulse to the activation input (terminals S33-S34) will allow the closing of safety output contacts (terminals 13-14, 23-24, 33-34, 43-44).

Reactivation

The safety system is reactivated when the feedback loop between terminals Y1 and Y2 is closed AND when there is a reactivation request (S24) between terminals S33 and S34.

Terminals Y3/Y4 allow one to choose whether or not this reactivation is to be monitored:

- When Y3/Y4 is open, the outputs are activated (recommended) when the PB is pressed then released (falling edge on S34),
- When Y3/Y4 is closed, the outputs are immediately activated when the PB is pressed.

NOTE:

- The shunt between terminals Y3-Y4 must be as short as possible,
- Do not connect anything else to these terminals.

A shunt on both Y3-Y4 and S33-S34 allows the outputs to be activated automatically as soon as the two input channels are closed. A de-synchronization time of 400 ms is allowed.

Safety output

The **TSX PAY 262** module features two outputs wired between terminals 13-14 and 23-24; these two outputs can be supplied independently.

The **TSX PAY 282** module features four outputs wired between terminals 13-14, 23-24, 33-34 and 43-44; these outputs are grouped together in pairs and each pair can be supplied independently.

The relays (with guided contacts) or switches connected upstream from the outputs must be inserted in the feedback loop between terminals Y1 and Y2. The device may only be switched on if those relays with safety-related functions which received a stop order have been deactivated. The feedback loop must be closed before any new start-up.

An additional external condition, managed by the API, may be inserted into the feedback loop to inhibit any reactivation in the event of a safety system fault being detected.

Functional diagrams

Introduction

This section provides the functional diagrams for the emergency stop functions and the protective cover with automatic start-up.

Emergency stop function

The following diagram shows the functional diagram for the emergency stop function:

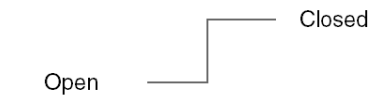
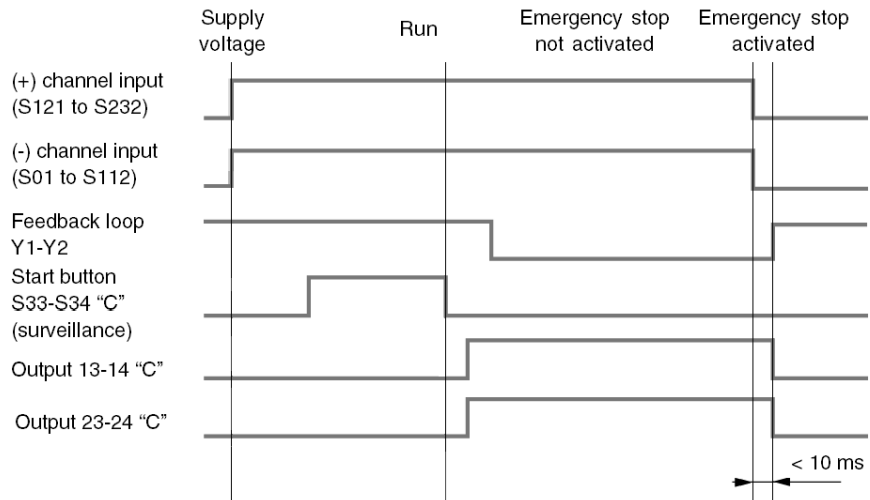

"C" on closing

Depending on the wiring of Y3-Y4, reactivation is carried out on edge or on state.

A single open ES PB contact opens the safety outputs.

Both channels must be open to allow reactivation to take place: this constitutes self checking of inputs.

Reactivation is only possible if the Y1-Y2 loop is closed: this constitutes self checking of outputs.

Protective cover function with automatic start-up

The following diagram shows the functional diagram for the protective cover function with automatic start-up:

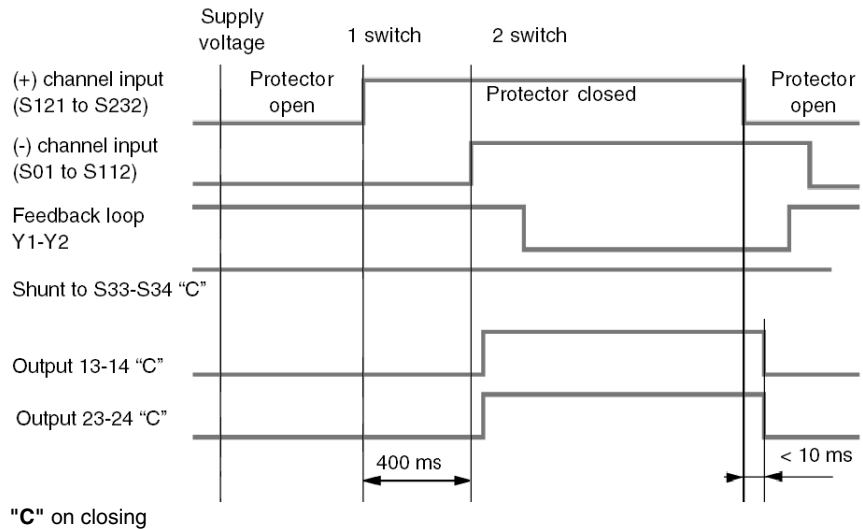

The use of the two distinct PSs (switch 1 and 2) requires the mechanical elements to respect a time delay of less than 400 ms upon closure of the 2 switches.

The manufacturer's characteristics guarantee inhibition of the command if the time is greater than 1 s. In this configuration, the automatic reset is selected.

32.3 General rules for the installation of safety modules

Overview

This section describes the installation of the module on the rack, and provides a description of the various markings on the module.

What's in this Section?

This section contains the following topics:

Topic	Page
Mounting Safety Modules	356
Identification of safety modules	358

Mounting Safety Modules

Introduction

All Premium range safety modules are standard format and therefore occupy one single position in the **TSX RKY...** racks.

They can be installed in any position in the rack, with the exception of the first two (PS and 00), which are reserved for the rack supply module (**TSX PSY...**) and the processor module (**TSX 57...**) respectively.

NOTE: The modules can be handled without switching off the rack supply, in complete safety and with no risk of damaging or disturbing the PLC. It is, however, imperative that the module cable be unplugged in order to deactivate the safety outputs before removing the output terminal block.

Illustration

The following diagram shows the procedure for mounting a safety module in the rack.

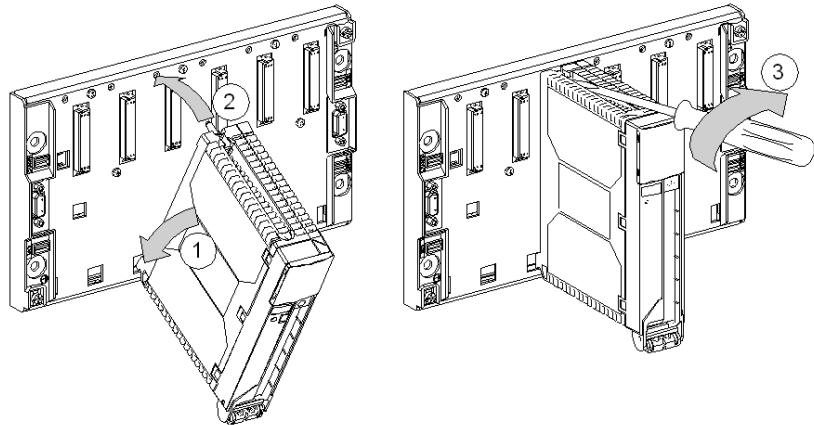

Description

The following table describes the procedure for installing a safety module in the rack.

Step	Action
1	Position the two locating pins situated at the rear of the module (lower section of the module) in the centering holes located in the lower section of the rack.
2	Pivot the module upwards so as to engage the rack connector.
3	Secure the module to the rack by tightening the fastening screw located on the upper part of the module.

 **WARNING**

UNEXPECTED SYSTEM BEHAVIOR - LOOSE MODULE

Do tighten the fastening module screw as mentioned in step 3, else the module may not remain in position in the rack.

Failure to follow these instructions can result in death, serious injury, or equipment damage.

Identification of safety modules

Introduction

The modules can be identified by the markings on the cover of the front panel and on the right-hand side of the modules.

Illustration

The following diagram shows a safety module:

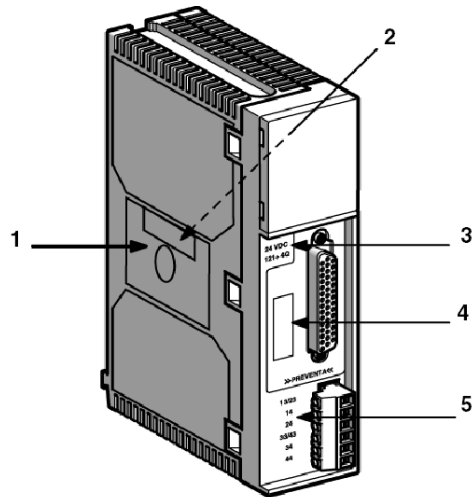

Elements

The following table gives a description of the different identifying elements of the safety modules:

Number	Description
1	Label giving the characteristics of the safety outputs (on left-hand side).
2	Label giving the module reference number (on right-hand side).
3	External module supply marking.
4	Unmarked area for user identification.
5	Front panel label for marking of safety outputs.

Terminal markings

Safety module terminals are marked in compliance with the following standards:
DIN EN 50005 and DIN EN 50042

Function	Terminals
External module power supply	A1-A2
System contact (+)	S01-S02, S11-S12, S21-S22, S31-S32, S41-S42, S51-S52, S61-S62, S71-S72, S81-S82, S91-S92, S101-S102, S111-S112
System contact (-)	S121-S122, S131-S132, S141-S142, S151-S152, S161-S162, S171-S172, S181-S182, S191-S192, S201-S202, S211-S212, S221-S222, S231-S232
Single and double contact selection	B1
Reactivation	S33-S34
Feedback loop	Y1-Y2
Reactivation input monitoring	Y3-Y4
Safety output supply	
<ul style="list-style-type: none"> ● TSX PAY 262 ● TSX PAY 282 	13-14, 23-24 13/23-14, 13/23-24, 33/43-34, 33/43-44

32.4 Precautions and general rules for wiring

Overview

This section outlines the recommendations and general rules for wiring.

What's in this Section?

This section contains the following topics:

Topic	Page
Wiring precautions	361
Cable dimensions and lengths	363

Wiring precautions

General

The safety system must be wired in accordance with EN60204-1. This section gives a description of the rules for wiring and mechanically protecting cables.

The entire safety system, the ES PBs or PSs, **TSX PAY 2•2** modules, protection fuses and auxiliary relays are incorporated in housings with an IP54 minimum protection index as per EN954-1.

Grounding

The module has no grounding terminal on its front panel. Depending on the **TSX CPP •02** cable being used, the 0 VDC can be grounded (cf. EN60204-1) directly via the TELEFAST **ABE-CPA13**.

NOTE: the **TSX CPP 301** cable has no ground connection.

Protection of safety system

Errors within the safety modules can be propagated to the outside of the module, particularly to the external supply in use: short circuits within the module can cause a supply voltage avalanche or a supply malfunction if it is not protected. For this, a 1 A (gL) quick-blow fuse is placed in the control section of the relays, given that maximum consumption is 200 mA.

NOTE: this fuse, called F1, is an active element of the safety system.

The module also contains a current limiting device set to 750 mA in order to detect inter-channel short circuits on the ES PBs or PSs. The external supply is protected in the event of this happening, and an error is indicated on the safety system.

In order to guarantee the safety function, it is compulsory to use the following:

- on input:
 - double contact ES PBs or PSs,
 - the NF contacts of the guided-contact auxiliary relays in the feedback loop.
- on output:
 - two or four guided-contact auxiliary relays,
 - a 4 A gL output protection fuse F2.
- on the external module supply:
 - a 1 A (gL) protection fuse F1.

Protection of safety outputs

Output voltages can reach 230 VAC or 127 VDC.

Outputs are not protected inside the module, though GMOV-type (for a continual load), or RC cell-type (for an alternating load) protection is applied directly to the terminals of the load in use. These protective measures must be adapted to the load.

The use of guided-contact auxiliary relays and the feedback loop wiring then make it possible to detect a safety output short circuit.

A 4 A (gL) quick-blow fuse is located in the auxiliary supply circuit to protect the module's safety relay contacts and the connected loads: this fuse is identical to that used in **PREVENTA** modules.

The fuse F2, located on the safety outputs, provides protection against short circuits and overloads. This protection avoids the melting of the safety relay contacts in **TSX PAY 2•2** modules.

Cable dimensions and lengths

General points

The length of safety system wires can cause a drop in supply voltage related to the current circulating. This voltage drop is due to sum of the currents circulating on the 0 VDC feedback path of the electrical circuit. It is usual practice to double or triple the 0 VDC wires.

In order to ensure the correct operation of the safety system (reactivation of relays) and a correct reading of diagnostic information, it is important that the voltage measured between terminals A1 and A2 be greater than 19.2 V.

Cross-section of TELEFAST cables

Each TELEFAST ABE-7CPA13 terminal accepts bare wires or ones fitted with terminations, or spade or eye terminals.

The capacity of each terminal is:

- minimum: 1 x 0.28 mm² wire without termination,
- maximum: 2 x 1 mm² wires or 1 x 1.5 mm² wire with termination.

The maximum cross-section dimensions for wires on the terminal block are: 1 x 2.5 mm² wire without termination.

Calculation of cable length

The resistance of each safety system ((+) channel and (-) channel) must not exceed 75 Ohms. The maximum resistance of the channel between an ES PB or PS and the corresponding input of the module must be $\leq 6 \Omega$

Given the length and cross-section of the cable, its resistance can be calculated as follows:

$$R = \rho \cdot \frac{l}{S}$$

Equation parameter

Parameter	Meaning
R	Cable resistance in Ohms
ρ	Resistivity: $1.78 \times 10^{-8} \Omega \cdot m$ for copper
l	Cable length in m
S	Cross-section in m ²

It is possible to wire the system so as to allow a greater distance between the ES PBs or PSs and the module:

Standard wiring:

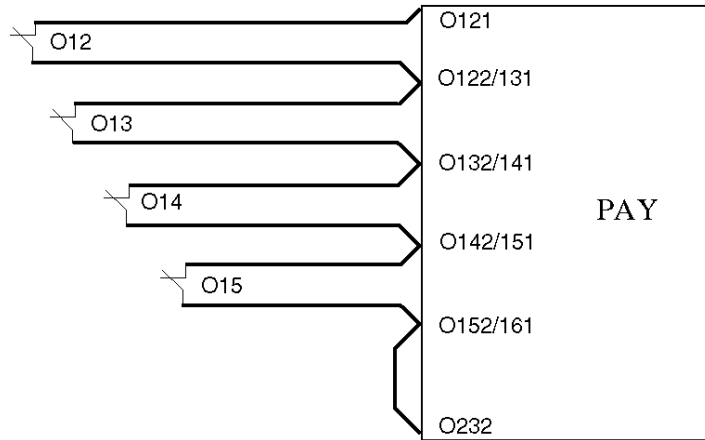

Optimized length wiring:

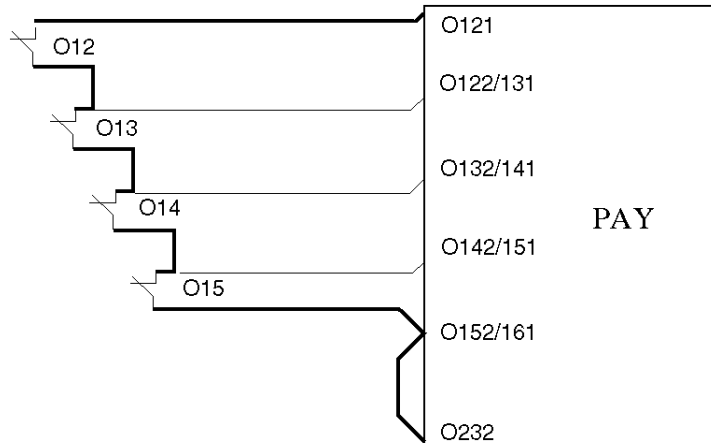

— : Length to be taken into account for calculation of the resistance.

32.5 Connection and wiring examples

Overview

The following section describes how safety modules are connected to the **TELEFAST 2** pre-formed cabling accessory using the **TSX CPP 301** cable, and provides examples of wiring.

What's in this Section?

This section contains the following topics:

Topic	Page
The safety system	366
TELEFAST pin assignment for safety modules	367
The TSX CPP 301 cable	370
Connection of emergency stop buttons and safety switches	372
Feedback loop connection	375
Reactivation connection	376
Safety outputs	377
Modules in series	378

The safety system

General

Either of the following may be used for cabling:

- the TSX CPP •02 cable with the TELEFAST ABE-7CPA13 connector,
- the TSX CPP 301 cable with loose thread ends.

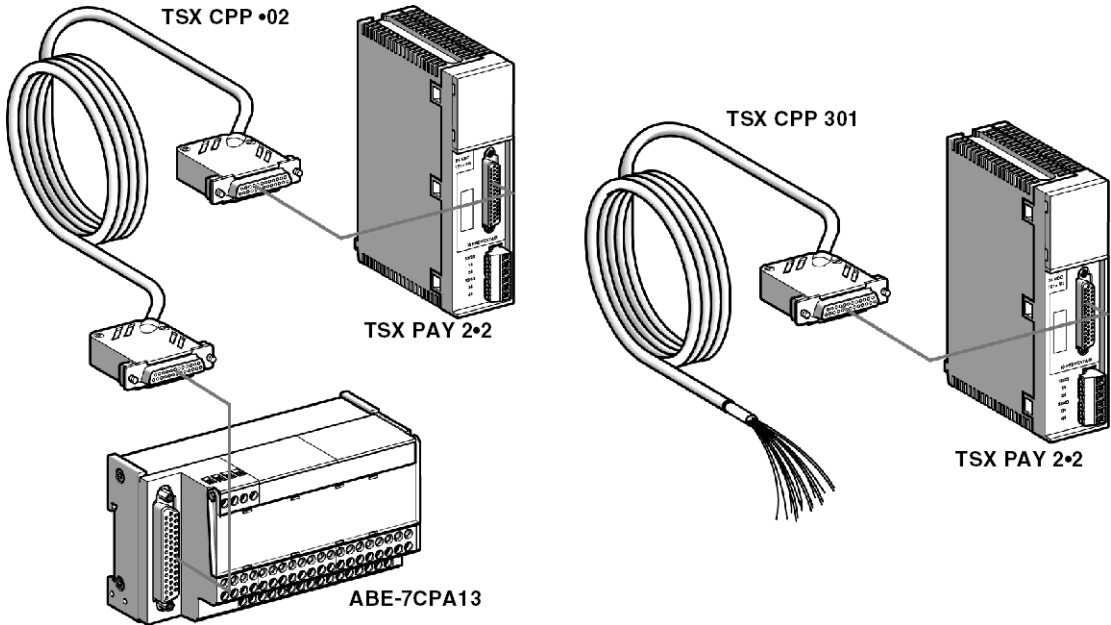

Risks exist under the following circumstances:

- modifications are made to the wiring diagrams, either by changing connections or adding components where these are insufficiently integrated into the safety circuit.
- the user does not respect the requirements of safety standards in terms of commissioning, operating, adjusting and maintaining the machine. It is imperative to maintain and check equipment on a yearly basis.
- the module is handled without having' shut off the power supply.

TELEFAST pin assignment for safety modules

General

The TELEFAST **ABE-7CPA13** described below is of "wire to wire"-type with no electronic components. This is used solely with **TSX PAY 2•2** safety modules. It facilitates implementation and wiring of the safety system to a machine. It transforms a Sub-D connector into a terminal block connector.

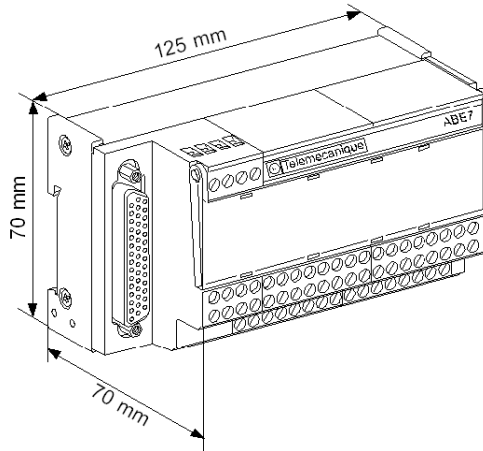

The maximum capacity of the TELEFAST terminal block terminals is:

- with termination: 2 x 1 mm² wires or 1 x 1.5 mm² wire,
- without termination: 1 x 2.5 mm² wire.

The TSX CPP •02 cable

The **TSX CPP •02** cable is a non-protected multiconductor cable made up of 32 conductors, whose colors comply with EN47100.

Its ends are fitted with unremovable male HD 44-pin Sub-D connectors.

The cable is available in three lengths: 1, 2 or 3 m.



⚠ DANGER

LOSS OF THE ABILITY TO PERFORM SAFETY FUNCTIONS

The **TSX CPP •02** module connection cable is part of the safety system. Do not modify this cable.

Failure to follow these instructions will result in death or serious injury.

Connections

The following table presents the correspondence between the safety module and the TELEFAST screw terminal blocks.

Marking	TELEFAST screw terminal block	Marking	TELEFAST screw terminal block
A1	37	S122/S131	32
A2/Y4	1-3	S132/141	30
B1	39	S142/S151	28
S01	33	S152/S161	26
S02/S11	31	S162/S171	24
S12/S21	29	S172/S181	22
S22/S31	27	S182/S191	20
S32/S41	25	S192/S201	18
S42/S51	23	S202/S211	16
S52/S61	21	S212/S221	14
S62/S71	19	S222/S231	12
S72/S81	17	S232	10-38
S82/S91	15	S33/Y2	5-7
S92/S101	13	S34	6
S102/S111	11	Y1	8
S112	9	Y3	4
S121	34-40	GND	2-35-36

NOTE: The TELEFAST **ABE-7CPA13** and **TSX CPP •02** cable are not supplied with the safety module.

Wiring examples

The following diagram shows the wiring of 5 emergency stops with reactivation surveillance.

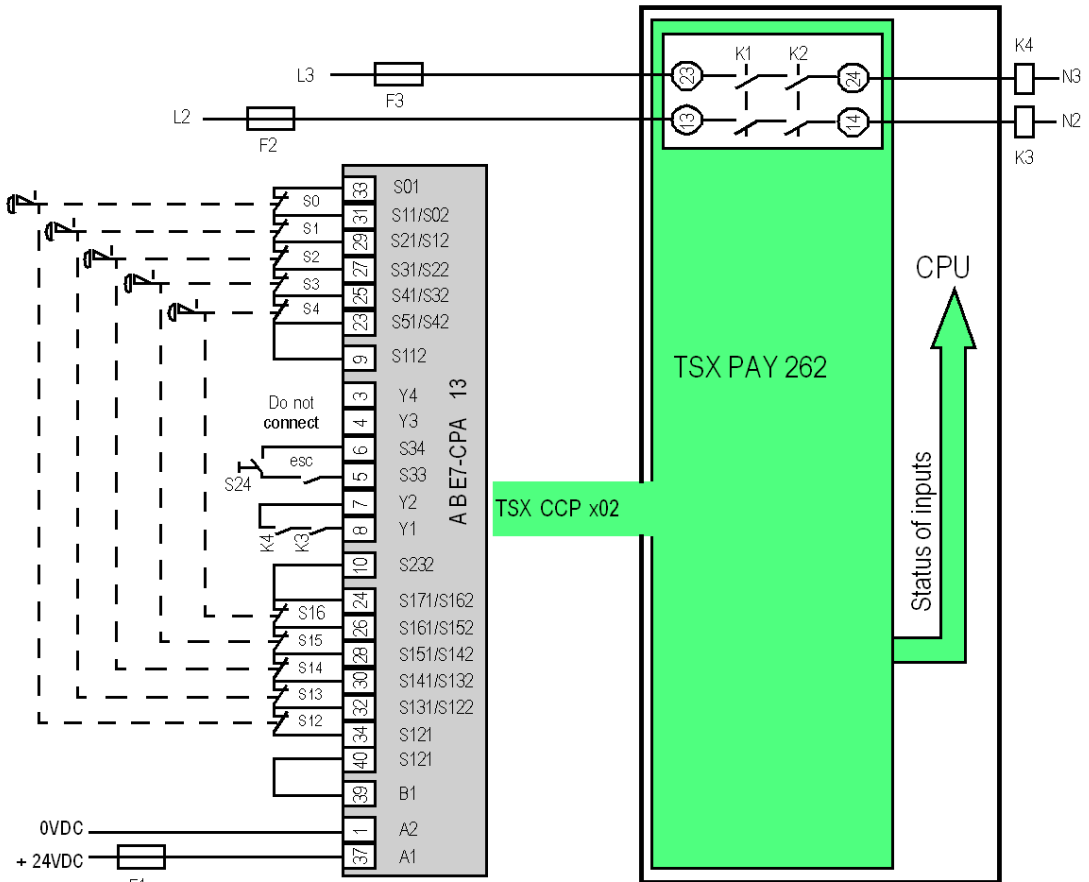

- Y1-Y2** Feedback loop.
- S33-S34** Operation validation.
- Y3-Y4** Choice of monitoring mode.
- S121 to S232** Input channel contact (+).
- S01 to S112** Input channel contact (-).
- A1-A2** external 24 VDC supply.
- B1** Selection of double or single contact wiring.
- 13-14, 23-24** Safety outputs (shared on TSX PAY 262 module).
- F1, F2 and F3** 1 A, 4 A and 4 A gL fuse (respectively).

The TSX CPP 301 cable

General

The **TSX CPP 301** cable is a non-protected multiconductor cable made up of 32 conductors (22 gauge, 7 threads).

One of its ends is fitted with an unremovable male HD 44-pin Sub-D connector, with the other made up of semi-stripped free threads: The sheath has been cut but the conductor is not stripped.

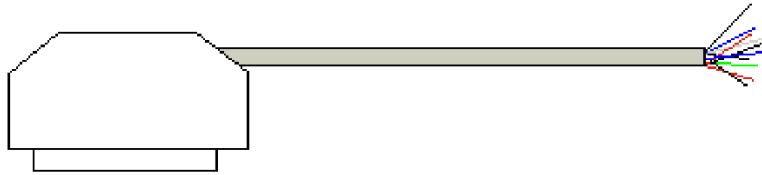

The cable is 3 m long.

Connections

The following table shows the **TSX CPP 301** cable's markings. Each thread is marked according to a color code, as per EN47100. The first color denotes the basic color of the conductor isolator, with the second denoting the color of the printed ring.

Marking	Sub-D connector pin	DIN 47100 color	Marking	Sub-D connector pin	DIN 47100 color
A1	16	Yellow/Brown	S122/S131	32	White/Blue
A2/Y4	30	White/Pink	S132/141	3	Green
B1	17	White/Gray	S142/S151	34	White/Red
S01	31	Pink/Brown	S152/S161	5	Gray
S02/S11	2	Brown	S162/S171	36	White/Black
S12/S21	33	Brown/Blue	S172/S181	7	Blue
S22/S31	4	Yellow	S182/S191	38	Gray/Green
S32/S41	35	Brown/Red	S192/S201	9	Black
S42/S51	6	Pink	S202/S211	40	Pink/Green
S52/S61	37	Brown/Black	S212/S221	11	Gray/Pink
S62/S71	8	Red	S222/S231	42	Green/Blue
S72/S81	39	Yellow/Gray	S232	13	White/Green
S82/S91	10	Violet	S33/Y2	15	White/Yellow

Marking	Sub-D connector pin	DIN 47100 color	Marking	Sub-D connector pin	DIN 47100 color
S92/S101	41	Yellow/Pink	S34	28	Gray/Brown
S102/S111	12	Red/Blue	Y1	44	White (1)
S112	43	Yellow/Blue	Y3	14	Brown/Green
S121	1	White (1)			
Legend:					
(1)	The white wire is used for both S121 and Y1 signals				

NOTE: It is not possible to transfer the ground (GND) with the **TSX CPP 301** cable
The **TSX CPP 301** cable is not supplied with the module.

Connection of emergency stop buttons and safety switches

General points

Connections for emergency stop buttons (ESB) or position switches (PS) can be wired with a single or double contact. However, only double contact wiring can provide category 3 or 4 levels of safety.

Double contacts (recommended)

Double contact wiring of inputs is suitable for applications requiring category 3 or 4 compliant levels of safety.

Short circuits between channels are detected.

ES PB or PS short circuits are detected and pinpointed.

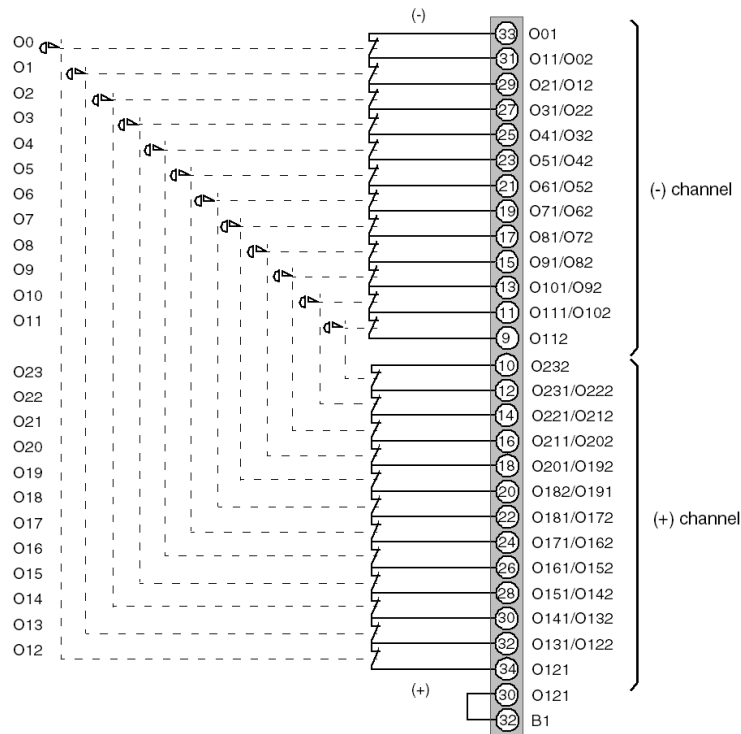

TELEFAST terminals

NOTE: If less than 12 double contacts are being used, the input terminals that are not in use must be bridged.

Example

Contacts S7 to S11 and S19 to S23 are not in use.

Bridge the following terminals: S71/S62 and S112; and S191/S182 to S232.

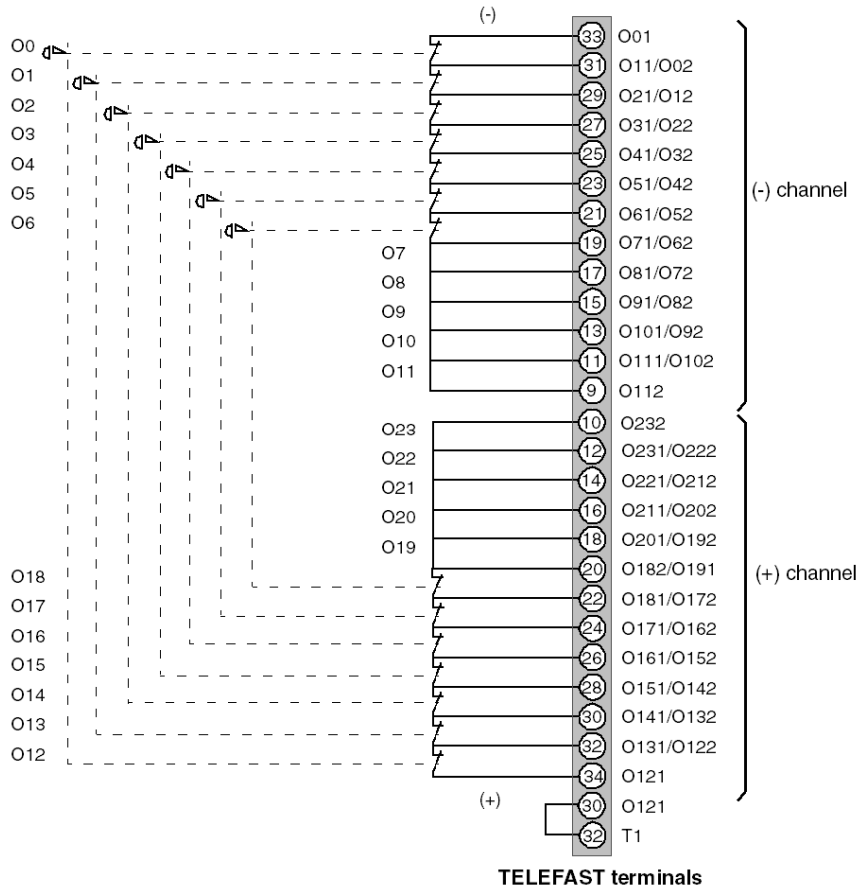

Single contact

This wiring is not suitable for applications requiring category 3 or 4 compliant levels of safety.

Not all errors are detected, nor are ES PB or PS short circuits. Here, pressing this PB will not cause the safety circuits to open (loss of the safety function).

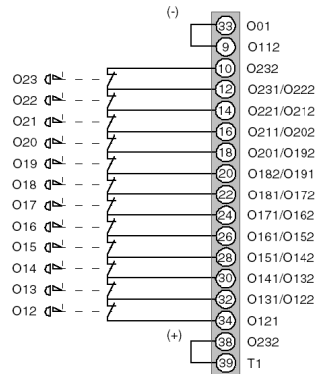

TELEFAST terminals

NOTE: If less than 12 contacts are being used, the input terminals that are not in use must be bridged.

Example

Contact S18 not in use.

Bridge the following terminals: S172/S181 and S182/S191.

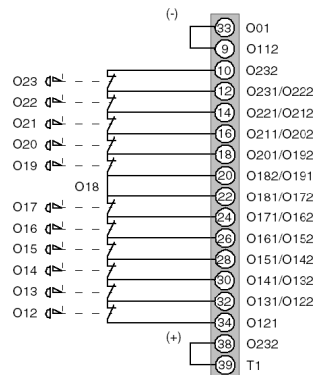

TELEFAST terminals

Feedback loop connection

General

The category 4 immediate stop system design requires supply shut-off device redundancy and activation monitoring.

Wiring of open contacts (K3, K4) or (K3, K4, K5, K6) allows every activation request to be checked.

It is compulsory for the contacts of relays (K3, K4) or (K3, K4, K5, K6) to be mechanically linked.

Category 3 wiring means:

- no wiring of auxiliary contacts in the feedback loop (a strap links terminals Y1 and Y2/S33),
- standard switches, with non-guided contacts, are sufficient.

2-switch set-up (category 4):

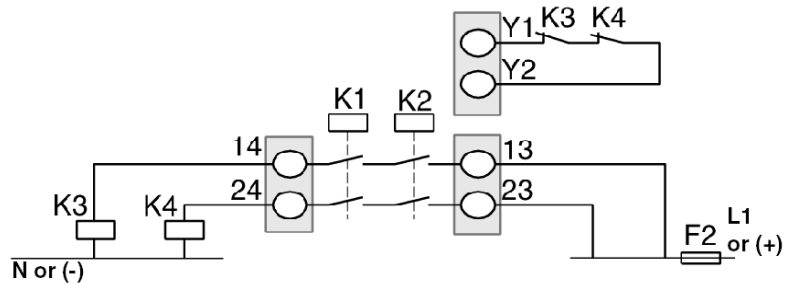

4-switch set-up (category 4):

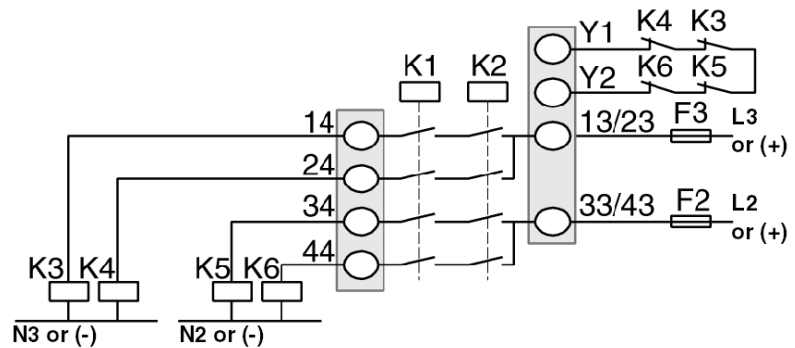

Reactivation connection

Introduction

This section shows the different ways of wiring the safety system reactivation function.

Automatic reactivation

Wiring diagram for automatic reactivation (protective cover):

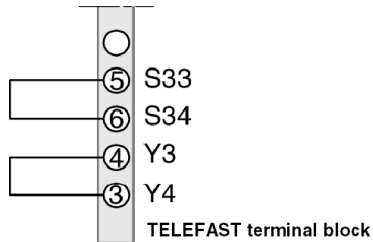

Manual reactivation

Once every ES PB or PS is unlocked, it is possible to choose whether or not to monitor manual reactivation of the safety system. The different wiring diagrams for manual reactivation are shown below.

With Reactivation button monitoring (recommended):

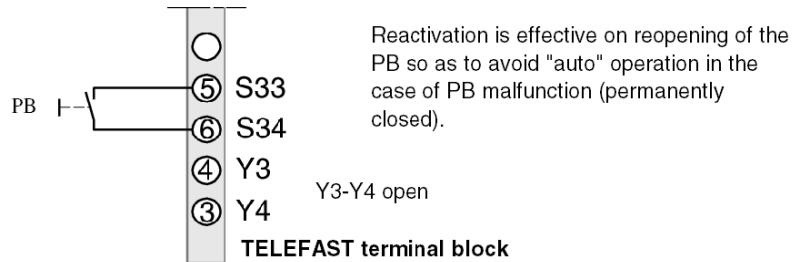

Without Reactivation button monitoring:

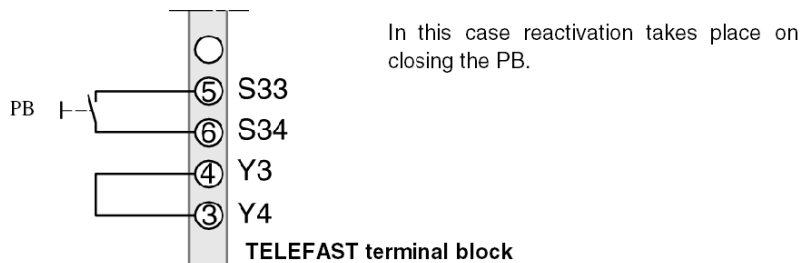

Safety outputs

General

Outputs are wired to the 6-point screw terminal block, for both the TSX PAY 262 and TSX PAY 282 modules.

TSX PAY 262 module

Wiring diagram for TSX PAY 262:

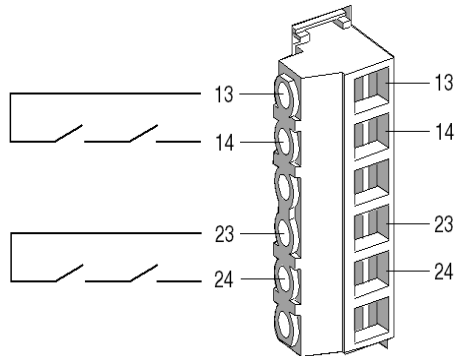

13 and 23 Independent supply input
14 and 24 Safety outputs

TSX PAY 282 module

Wiring diagram for TSX PAY 282:

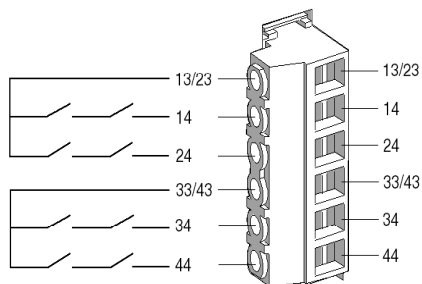

13/23 and 33/43 Independent supply input
14, 24, 34 and 44 Safety outputs

NOTE: Cross-section of wires:

- with termination: 2 x 1 mm² wires or 1 x 1.5 mm² wire,
- without termination: 1 x 2.5 mm² wire.

Modules in series

Introduction

For applications using over 12 single or double-contact inputs, it is possible to use several TSX PAY 2•2 modules.

No matter how the safety system is wired, the following must be applied:

- wiring of the safety module outputs in series,
- wiring of as many S33/S34 reactivation contacts as there are modules in series (electrically insulated contacts); the reactivation contacts cannot be connected in parallel,
- wiring of the K3/K4 feedback loop on one of the modules, and of a bridge between terminals Y1/Y2 on the other modules,
- wiring of the safety system inputs to each module independently (no connection in series).

The following diagrams show the cables for the safety module connected in series for use with 2 or 4 contactors:

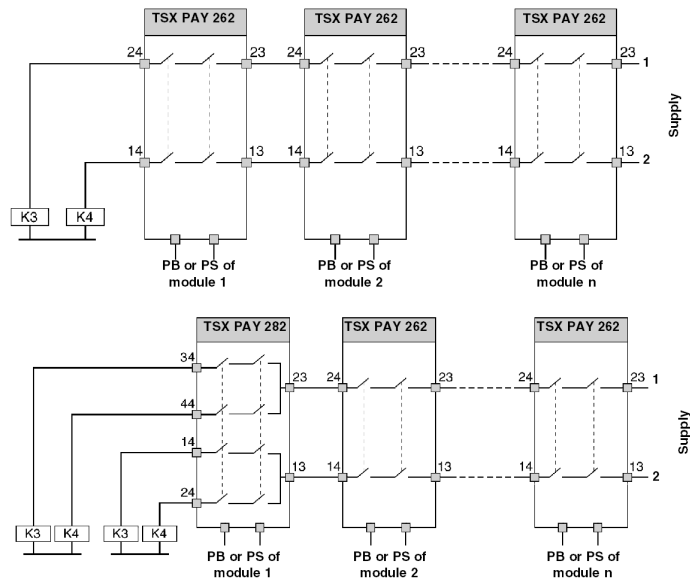

NOTE: Attention must be paid, however, to the drop in voltage on the output system, due to the 0.1 Ohm safety relay contact resistance, which depends on the relayed current.

For a 2.5 A thermal current, there will be a 4 V drop in power with 16 safety modules and a 16 V drop with 32 safety modules in series.

32.6 Maintenance and diagnostics

Overview

The following chapter describes the faults which may occur during operation of **TSX PAY 2•2** modules.

What's in this Section?

This section contains the following topics:

Topic	Page
Fault detection	380
Displaying safety module faults	382
Diagnostics of safety modules	383
Maintenance table	385
Test procedure	387

Fault detection

Introduction

This section describes the faults that can be detected by the safety modules.

On inputs

The module is able to detect a short-circuit between the two channels ES PB and PS, in which case the bit Ix.27 signals a fault in the safety system.

The module also self-checks inputs, where used with double contacts: if the states of the ES PBs or PSs are inconsistent when they are activated, the safety outputs are opened but reactivation is no longer possible.

In order to store a fault in the memory, it is imperative to:

- maintain a permanent supply,
- activate only one ES PB at a time (ES short circuit detection).

Application solutions, which use an API output in the feedback loop and which are able to detect faults thanks to module diagnostics data, make it possible to improve the conditions under which faults are stored.

On outputs

In order to detect output faults, it is necessary to use auxiliary relays with mechanically linked contacts (cf. Télémécanique safety applications components catalogue): this constitutes self checking of outputs.

The "NF" contacts of relays K3 and K4 must be looped back into the feedback loop in series, between terminals Y1 and Y2. This wiring prevents the safety system from being reactivated when one of the two control relays (K3 or K4) sticks.

Internal module faults

In the event of the failure of an internal component, the safety modules continue to perform safety functions by opening the output contacts (K1, K2) directly, or when they are next activated (opening an ES PB or PS or powering down). If this occurs, it is impossible to close output contacts (K1, K2). It is then advisable to change the module.

Where such a fault causes over-consumption on the 24 VDC, a limit of 750 mA is imposed. In this case, the bit Ix.27, indicating the status of the safety system, switches to 0, and the fault is signaled.

Ground faults

The safety modules have been built to comply with EN60204-1, which deals specifically with short circuits to ground. Given that the 0 VDC is grounded, the consequences of one or several short circuits to ground can be:

- the short circuiting of one or more of the ES PBs to the negative pole, where double contacts are in use.
The outputs open on activation of an ES PB or PS by opening the contact to the positive pole, with reactivation no longer being possible due to the self-checking of inputs,
- the short circuiting of the 24 VCC external supply, whether single or double contact wiring is in use.
No supply to the safety system leading to immediate opening of the safety outputs. The A1-A2 external supply is protected by the 750 mA current limit and a fault is indicated in the safety system.

Limitations

Pressing a short circuited ES PB or PS opens the safety outputs and the self-checking means reactivation is impossible. But opening a second ES PB or PS prior to reactivation renders self-checking ineffective, as here both channels reach a consistent state.

Input self-checking is also made ineffective if a cut in external supply occurs (or is caused) following the activation of a faulty ES PB or PS, as the module is reinitialized on power-up and reactivation is possible once more.

Displaying safety module faults

At a Glance

The safety modules are fitted with LED allowing module and channel status to be displayed. We can see :

- the module status LEDs : **RUN**, **ERR** and **I/O**,
- the channel status LEDs : **CH**.

Illustration

The following diagram shows the safety module display screen :

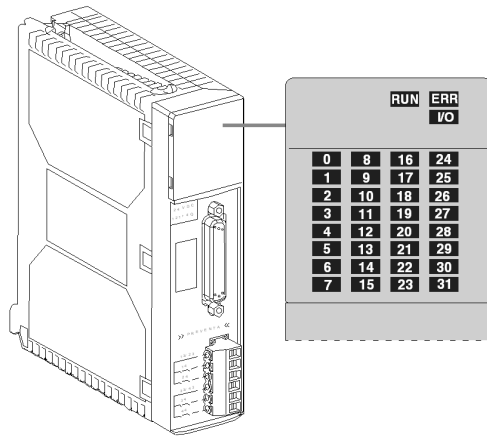

Description

Depending on their status (on, flashing or off) the three LEDs located on each module provide information on the operational state of the module :

- The green **RUN** LED: indicates that the module is operational
- The red **ERR** LED: indicates an internal module fault or a fault between the module and the rest of the configuration.
- The red **I/O** LED: indicates an external fault.
- LEDs 0 to 27 indicate the status of the safety system.
 - 0 to 11 : status of ES PB or PS (-) channel contacts,
 - 12 to 23 : status of ES PB or PS (+) channel contacts,
 - 24 : reactivation input status,
 - 25 : feedback loop status,
 - 26 : safety relay control status,
 - 27 : supply present on the safety system, safety system diagnostics.
- LEDs 28 to 31 are not used.

Diagnostics of safety modules

At a Glance

A faulty module will be indicated by the lighting up or flashing of the **RUN**, **ERR** and **I/O** LEDs.

There are three classes of fault:

- external errors,
- internal errors,
- other errors.

Internal faults are the result of a safety module self-check.

External faults are linked to the safety modules' external supply.















State of module

The following table allows a failure diagnosis to be made on the basis of the three LEDs: **RUN**, **ERR** and **I/O**.

State of module	Status LEDs		
	RUN	ERR	I/O
Rack off or module fault	○	○	○
Normal operation or module not recognized if no supply	●	○	○
Faulty module	○	●	○
External supply fault	○	○	●
Module and external supply fault	○	●	●
External fault: 24 VDC (<19 VDC) external supply	●	○	●
Internal fault (module faulty)	●	●	○
General fault (short circuit, etc.)	●	●	●
Legend:			
○	LED off		
●	LED on		

Safety system status

The following table enables us to determine the status of the safety system using LEDs 0 to 31:

LEDs	State	Meaning
0 to 23	 	ES PB or PS contact open ES PB or PS contact closed
24	 	Reactivation input open or feedback loop open Reactivation input closed and feedback loop closed
25	 	Feedback loop open Feedback loop closed
26	 	K1 and K2 SS relays non-controlled K1 and K2 SS relays controlled
27	 	SS supply fault or fault causing a short circuit between safety system channels SS supply present
28 to 31	 	LED not in use
Legend:		
	LED off	
	LED on	
SS	Safety System	

NOTE: an external supply fault causes the module's **I/O** LED to come on. The display block LEDs always show channel status, even if there is a fault on the channel.

It is possible to set up external supply surveillance: for this, the LEDs of the display block reflect the real status of the ES, PB or PS.

Maintenance table

At a Glance

The following section shows the maintenance table for safety modules.

Faults	Possible causes	Check
Unsolicited opening of safety outputs	No external supply or fuse F1 blown	Read %lx.MOD.ERR = external fault Check I/O LED on the module Voltage >19.2 VDC between terminals A1-A2 If %lx.27=0 then SC on SS
	ES PB or PS contact open	Read %lx.0 to %lx.23 Check consistency of contact status
	B1 disconnected	Check B1 linked to : <ul style="list-style-type: none"> ● S232 for (single contact) ● S121 for (double contact)
	Loss of relay control F2 Fuse blown	Read %lx.26 Check F2 status and characteristics
Start-up impossible	No external supply or fuse F1 blown	Read %lx.MOD.ERR = external fault Check I/O LED on the module Voltage >19.2 VDC between terminals A1-A2
	Emergency stop remains open	Read %lx.0 to %lx.23 Check consistency of contact status
	Inconsistency between double contact inputs (wires cut or faulty ES PB) : self-check	Read %lx.0 to %lx.23 Check consistency of contact status
	No ES PB action possible with feedback loop closed	%lx.24=%lx.25=1 on PB action Check PB contacts Check Y3-Y4 shunt status
	Feedback loop remains open Control impossible	Read %lx.25 Check auxiliary relay contacts Read %lx.26 on PB action
	Fuse F2 blown	Check F2 status and characteristics
	Output supply not functioning	Check reactivation wiring
Automatic start-up	Permanent PB activation with a closed loop	%lx.24=%lx.25=1 without PB action Check PB contacts

Faults	Possible causes	Check
False input data	Voltage drop on cables	Voltage between terminals S01-S112 and S121-S232 > 18.2 VDC all ES PBs closed
Legend :		
SC	Short Circuit	
SS	Safety System	
ES PB	Emergency Stop Push Button	
PS	Position Switch	

NOTE: If the fault persists, following wiring check, the module should be changed.

To avoid errors when replacing a product, it is recommended to mark the slot on the module label on the front panel and the TSX CPP •02 cable label. The specific red color of the TSX PAY 2•2 modules front panel allows errors to be avoided during PLC maintenance operations.

Test procedure

Introduction

Before using the installation or during a periodic check (service), it may be useful to test the module and its functions. This procedure used may be as follows:

External supply

The module has a built-in external supply check. A module is declared faulty if voltage falls below 19 VDC.

The module's I/O LED lights up to signal the supply fault.

In this situation, the module's safety system remains operational: a drop in voltage to 10 VDC also causes safety outputs to open, thus switching to the safe position.

The module is protected against polarity reversals, and contains a current limiter set to 750 mA.

In the event of the external supply check not being activated (at set-up), supply faults are not indicated.

Emergency stop input

With the outputs closed, activate every emergency stop, one at a time, in order to check that outputs switch to safety mode: LED 26 should switch from on to off.

Check safety system activation and that diagnostic data is consistent.

Feedback loop input

The feedback loop provides the module with a real image of the safety outputs; it is open when outputs are active. The device used is a guided-contact relay for controlling outputs.

- Open loop: LED 25 off,
- Closed loop: LED 25 on.

Check the status of the feedback loop in relation to the output control.

Activation of reactivation input

Activating the reactivation input between terminals S33 and S34 allows the system to be reactivated when no ES has been requested AND if the feedback loop is closed; the device used is a push button (activated on falling edge or status).

It is only possible to read the status of the reactivation input if the feedback loop is also closed.

- Open contact: LED 24 off,
- Closed contact: LEDs 24 and 25 on.

Depending on which reactivation option has been chosen, check for correct operation and check the diagnostic indicators.

Output control status

Depending on the module - TSX PAY 262 or TSX PAY 282 – two or four outputs are available between terminals 13-14, 23-24, 33-34 and 43-44. These outputs allow the contactors or pre-actuators to be controlled, and this section is isolated from the control section (reactivation).

When the reactivation conditions are satisfied (feedback loop closed AND reactivation input activated), outputs can be controlled.

- Outputs idle: LED 26 off,
- Outputs active: LED 26 on.

32.7 TSX PAY 262 module

Overview

This section describes the characteristics of the **TSX PAY 262** module.

What's in this Section?

This section contains the following topics:

Topic	Page
Presentation of the TSX PAY 262 module	390
Characteristics of the TSX PAY 262 module	391

Presentation of the TSX PAY 262 module

Introduction

TSX PAY 262 module.

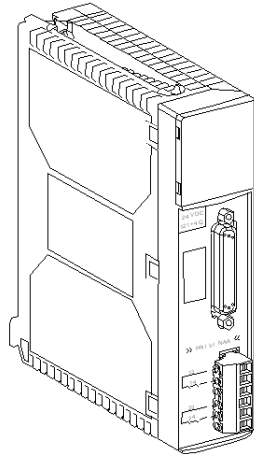

The **TSX PAY 262** module is an I/O safety module developed to comply with the requirements of European and international standards for electronic industrial automation equipment and safety circuits.

Characteristics of the TSX PAY 262 module

Introduction

This section describes the general characteristics of the **TSX PAY 262** module, its input / output characteristics, operating conditions and applied standards.

General characteristics

The following table shows the general characteristics of the **TSX PAY 262** module

Safety functions	ES PB and PS monitoring	Yes (1 to 12 single or double contacts)
	Moving cover monitoring	Yes (de-synchronization > 400 ms)
	Sensitive conveyor monitoring	No
	Bi-manual control	No
EN 954-1 category		4
External module power supply A1-A2 terminal	Voltage	24 VDC
	Residual ripple	5%
	Voltage limit	-15% +20%
	F1 fuse external supply protection (according to IEC 947-5-1)	< 1A gL
	Maximum consumption	200 mA
	Check threshold	< 19 VDC
	Maximum current call	0,5 A / 5 ms
	safety circuit voltage	24 VDC
	Module protection	Internal electronic fuse > 250 mA and < 1 A
Insulation	Over-voltage category II (2 kV), pollution degree 2	
PLC supply, current consumed with internal 5 V supply		150 mA
Power dissipated in the module		< 5 W
Dimensions	H x W x D	150 x 36 x 120 mm
	Weight	0,43 kg
MTBF	Module	3×10^{-6} failures/hour
	Relay card	0.5×10^{-6} failures/hour
	Mother board	2.4×10^{-6} failures/hour

Input characteristics

The following table shows the characteristics of the **TSX PAY 262** module inputs

No. of safety channels	12 single or double ES PBs
Reactivation / On button	Yes (S33-S34)
Single or double ES PB selection	Yes with external shunt (B1)
Feedback loop	Yes (Y1-Y2)
Reactivation input monitoring	Yes with external shunt (Y3-Y4)
Call current	0,5 A / 1 ms
Input / Ground insulation	500 V actual 50/60 Hz - 1 min

Output characteristics

The following table shows the characteristics of the **TSX PAY 262** module outputs

Potential reference	No potential	
Number and type of circuits	2 x normally open with independent supply	
DIN EN 60947-5-1 cut-off power	AC15 / C300: 1800 VA call 180 VA maintained Dc13: 24 V/2.5 A L/R=100 ms	
Voltage	19..250 VAC/17..127 VDC	
Outputs protected by fuses (compliant with EN VDE 0660 section 200 and IEC 947-5-1)	4 A gL	
Maximum thermal current	2,5 A	
Minimum current and voltage	30 mA and 24 VDC	
ES request response time	< 10 ms	
Mechanical durability	10 ⁶ maneuvers	
Electrical durability	10 ⁶ maneuvers (depending on power)	
Insulation	Output / Weight	300 V insulation voltage compliant with VDE 0110 / section 1
	Test voltage	2000 V actual 50/60 Hz - 1 min
	Safety System / Ground	300 V actual

NOTE: the apparatus is capable of switching low loads (24 V/30 mA). This is possible on condition that the contact has never previously switched heavy loads, as the gold layer on the contact may have been damaged.

Operating conditions

The following table shows the characteristics for using the **TSX PAY 262** module

Operating temperature	Of the API	0..60° C
	Of the safety functions 1	-10..60° C
Humidity without condensation		5..95%
Storage temperature		-25..70° C
Insulation resistance		> 10 MW below 500 VDC
Dielectric strength on Sub-D compliant with IEC1131		500 V actual, 50/60 Hz, 1 min
Operating altitude		0..2000 m
Degree of protection compliant with IP IEC 529	Terminals/Unit	IP20
	Place of installation	IP54
Maximum capacity of screw terminal blocks		2 x 1 mm ² wires with termination,

Standards

The following table shows the European and international standards the **TSX PAY 262** module meets.

PLC-specific recommendations	EN61131-2 (IEC 1131-2), CSA 22-2 No.142, UL508
Electrical qualities	UL746L, UL94
Electrical equipment of machinery	EN60204-1 (IEC204-1)
Emergency stop equipment	EN418
Machine safety – Related control system parts	EN954-1, PR EN954-2 EN953, EN1088 DIN VDE 0110, DIN VDE 0660 EN60947-5-1, VDE 57100 NF C63-850, IEC 664

32.8 TSX PAY 282 module

Overview

This section describes the characteristics of the **TSX PAY 282** module.

What's in this Section?

This section contains the following topics:

Topic	Page
Presentation of the TSX PAY 282 module	395
Characteristics of the TSX PAY 282 module	396

Presentation of the TSX PAY 282 module

Introduction

TSX PAY 282 module.

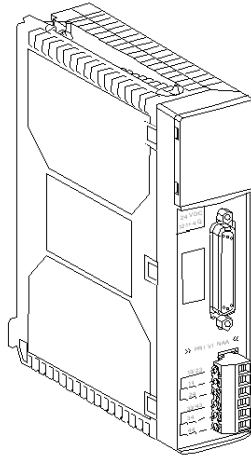

The **TSX PAY 282** module is an I/O safety module developed to comply with the requirements of European and international standards for electronic industrial automation equipment and safety circuits.

Characteristics of the TSX PAY 282 module

Introduction

This section describes the general characteristics of the **TSX PAY 282** module, its input / output characteristics, operating conditions and applied standards.

General characteristics

The following table shows the general characteristics of the **TSX PAY 282** module

Safety functions	ES PB and PS monitoring	Yes (1 to 12 single or double contacts)
	Moving cover monitoring	Yes (de-synchronization > 400 ms)
	Sensitive conveyor monitoring	No
	Bi-manual control	No
EN 954-1 category		4
External module power supply A1-A2 terminal	Voltage	24 VDC
	Residual ripple	5%
	Voltage limit	-15% +20%
	F1 fuse external supply protection (according to IEC 947-5-1)	< 1A gL
	Maximum consumption	200 mA
	Check threshold	< 19 VDC
	Maximum current call	0,5 A / 5 ms
	Safety circuit voltage	24 VDC
	Module protection	Internal electronic fuse > 250 mA and <1 A
Insulation	Over-voltage category II (2 kV), pollution degree 2	
PLC supply, current consumed with internal 5 V supply		150 mA
Power dissipated in the module		< 5 W
Dimensions	H x W x D	150 x 36 x 120 mm
	Weight	0,49 kg
MTBF	Module	3×10^{-6} failures/hour
	Relay card	0.5×10^{-6} failures/hour
	Mother board	2.4×10^{-6} failures/hour

Input characteristics

The following table shows the characteristics of the **TSX PAY 282** module inputs

No. of safety channels	12 single or double ES PBs
Reactivation / On button	Yes (S33-S34)
Single or double ES PB selection	Yes with external shunt (B1)
Feedback loop	Yes (Y1-Y2)
Reactivation input monitoring	Yes with external shunt (Y3-Y4)
Call current	0,5 A / 1 ms
Input / Ground insulation	500 V actual 50/60 Hz - 1 min

Output characteristics

The following table shows the characteristics of the **TSX PAY 282** module outputs

Potential reference	No potential	
Number and type of circuits	4 x normally open with shared supply	
DIN EN 60947-5-1 cut-off power	AC15 / C300: 1800 VA call 180 VA maintained DC13: 24 V/2.5 A L/R=100 ms	
Voltage	19..250 VAC/17..127 VDC	
Outputs protected by fuses (compliant with EN VDE 0660 section 200 and IEC 947-5-1)	4 A gL	
Maximum thermal current	2,5 A	
Minimum current and voltage	30 mA and 24 VDC	
ES request response time	< 10 ms	
Insulation	Output / Weight	300 V insulation voltage compliant with VDE 0110 / section 1
	Test voltage	2000 V actual 50/60 Hz - 1 min
	Safety System / Ground	300 V actual
Mechanical durability	10 ⁶ maneuvers	
Electrical durability	10 ⁶ maneuvers (depending on power)	

NOTE: the apparatus is capable of switching low loads (24 V/30 mA). This is possible on condition that the contact has never previously switched heavy loads, as the gold layer on the contact may have been damaged.

Operating conditions

The following table shows the characteristics for using the **TSX PAY 282** module

Operating temperature	Of the API	0..60° C
	Of the safety functions 1	-10..60° C
Humidity without condensation		5..95%
Storage temperature		-25..70° C
Insulation resistance		> 10 MW below 500 VDC
Dielectric strength on Sub-D compliant with IEC1131		500 V actual, 50/60 Hz, 1 min
Operating altitude		0..2000 m
Degree of protection compliant with IP IEC 529	Terminals/Unit	IP20
	Place of installation	IP54
Maximum capacity of screw terminal blocks		2 x 1 mm ² wires with termination,

Standards

The following table shows the European and international standards the **TSX PAY 282** module meets.

PLC-specific recommendations	EN61131-2 (IEC 1131-2), CSA 22-2 No.142, UL508
Electrical qualities	UL746L, UL94
Electrical equipment of machinery	EN60204-1 (IEC204-1)
Emergency stop equipment	EN418
Machine safety – Related control system parts	EN954-1, PR EN954-2 EN953, EN1088 DIN VDE 0110, DIN VDE 0660 EN60947-5-1, VDE 57100 NF C63-850, IEC 664

Discrete Input/Output Modules Software Implementation



In This Chapter

This part describes the Discrete application specific function for Premium controllers and describes its implementation with the Unity Pro software.

What's in this Part?

This part contains the following chapters:

Chapter	Chapter Name	Page
33	General Information about the Discrete Application-Specific Function	401
34	Configuration of the Discrete Specific-Application	403
35	Description of the Discrete Specific-Application Language Objects	421
36	Debugging of discrete modules	449
37	Diagnostic of discrete modules	459
38	Installation of the discrete reflex module	463

General Information about the Discrete Application-Specific Function

33

Installation Phase Overview

Introduction

The software installation of the application-specific modules is carried out from the various Unity Pro editors:

- in offline mode
- in online mode

If you do not have a processor to connect to, Unity Pro allows you to carry out an initial test using the simulator. In this case the installation (*see page 402*) is different.

The following order of installation phases is recommended but it is possible to change the order of certain phases (for example, starting with the configuration phase).

Installation Phases with Processor

The following table shows the various phases of installation with the processor:

Phase	Description	Mode
Declaration of variables	Declaration of IODDT-type variables for the application-specific modules and variables of the project.	Offline (1)
Programming	Project programming.	Offline (1)
Configuration	Declaration of modules.	Offline
	Module channel configuration.	
	Entry of configuration parameters.	
Association	Association of IODDTs with the channels configured (variable editor).	Offline (1)
Generation	Project generation (analysis and editing of links).	Offline
Transfer	Transfer project to PLC.	Online
Adjustment/Debugging	Project debugging from debug screens, animation tables.	Online
	Modifying the program and adjustment parameters.	

Phase	Description	Mode
Documentation	Building documentation file and printing miscellaneous information relating to the project.	Online (1)
Operation/Diagnostic	Displaying miscellaneous information necessary for supervisory control of the project.	Online
	Diagnostic of project and modules.	
Key:		
(1)	These various phases can also be performed in the other mode.	

Implementation Phases with Simulator

The following table shows the various phases of installation with the simulator.

Phase	Description	Mode
Declaration of variables	Declaration of IODDT-type variables for the application-specific modules and variables of the project.	Offline (1)
Programming	Project programming.	Offline (1)
Configuration	Declaration of modules.	Offline
	Module channel configuration.	
	Entry of configuration parameters.	
Association	Association of IODDTs with the modules configured (variable editor).	Offline (1)
Generation	Project generation (analysis and editing of links).	Offline
Transfer	Transfer project to simulator.	Online
Simulation	Program simulation without inputs/outputs.	Online
Adjustment/Debugging	Project debugging from debug screens, animation tables.	Online
	Modifying the program and adjustment parameters.	
Key:		
(1)	These various phases can also be performed in the other mode.	

NOTE: The simulator is only used for the discrete or analog modules.

Configuration of the Discrete Specific-Application

34

Aim of this Section

This chapter describes how to configure Discrete specific-application for implementation.

What's in this Chapter?

This chapter contains the following sections:

Section	Topic	Page
34.1	Configuration of a Discrete module: General information	404
34.2	Discrete Input and Output Track Parameters	407
34.3	Configuration of discrete parameters	412

34.1 Configuration of a Discrete module: General information

Description of the Discrete Module Configuration Screen

At a Glance

The configuration screen is a graphic tool designed for configuring (*see Unity Pro, Operating Modes*) a module selected in a rack. It displays the parameters defined for this modules channels, and allows you to modify them in offline mode and online mode (function available for Unity Pro versions greater than 1.0).

It also provides access to modification and debug screens (the latter in online mode only).

NOTE: It is not possible to configure a module by programming using direct language objects %KW, these words are accessible in read only format.

Illustration

This screen enables the display and modification of parameters in offline mode, as well as debug in online mode.

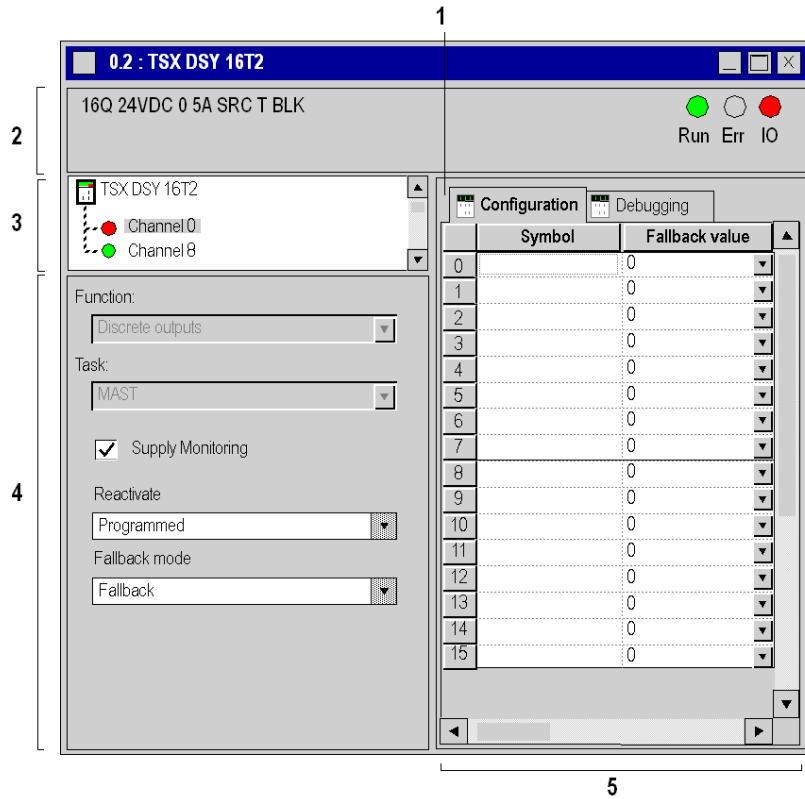

Description

The next table shows the various elements of the configuration screen and their functions.

Address	Element	Function
1	Tabs	The register tab in the foreground indicates the current mode (Configuration for this example). Every mode can be selected using the respective tab. The Debug mode is only accessible in online mode. The Settings mode is only available for the TSX DMY 28RFK (see page 468) module.
2	Module zone	Specifies the abbreviated heading of the module. In online mode, this zone includes also the three LEDs Run , Err , IO .
3	Channel field	Is used: <ul style="list-style-type: none"> ● By clicking on the reference number, to display the tabs: <ul style="list-style-type: none"> ● Description which gives the characteristics of the device. ● I/O Objects (see <i>Unity Pro, Operating Modes</i>) which is used to presymbolize the input/output objects. ● Fault which shows the device faults (in online mode). ● To select the channel, ● To display the Symbol, name of the channel defined by the user (using the variable editor).
4	General parameters field	Allows you to select the associated function and task in groups of 8 channels: <ul style="list-style-type: none"> ● Function: Defines the configuration/deconfiguration of the channel group selected (other than groups 0 to 7), ● Task: Defines the task (MAST, FAST or AUX0/3 (see page 413) in which channel default exchange objects will be exchanged. <p>The check box Supply monitoring defines the active or inactive state of the external power supply fault monitoring (available only on some Discrete modules). The Reactivate and Fallback mode drop-down menus enable you to configure the output reset and output fallback mode (available only on some Discrete modules).</p>
5	Configuration zone	Enables the configuration of parameters for the various channels. This field includes various items, displayed according to the selected Discrete module. The Symbol column displays the symbol associated with the channel when it has been defined by the user (using the variable editor).

34.2 Discrete Input and Output Track Parameters

Aim of this Section

This section presents the various parameters of input and output track for discrete modules.

What's in this Section?

This section contains the following topics:

Topic	Page
Discrete Input Parameters on the Rack	408
Discrete Output Parameters for 8 Channel Modules in Rack	410
Over 8 track modules on rack Discrete Output Parameter for Modules with more than 8 Channels on the Rack	411

Discrete Input Parameters on the Rack

At a Glance

The Discrete input module includes parameters by channel, by group of 8 or 16 consecutive channels.

Parameters

The following table displays the parameters available for each in-rack Discrete input module.

Reference module	No. of inputs	Associated task (8 channel group)	Function (by channel)	Filter (by channel)	On. Power supply fault (16 channel group)
TSX DEY 08D2	8	Mast / Fast / AUXi	-	-	Active / Inactive
TSX DEY 16A2	16	Mast / Fast / AUXi	-	-	Active / Inactive
TSX DEY 16A3	16	Mast / Fast / AUXi	-	-	Active / Inactive
TSX DEY 16A4	16	Mast / Fast / AUXi	-	-	Active / Inactive
TSX DEY 16A5	16	Mast / Fast / AUXi	-	-	Active / Inactive
TSX DEY 16D2	16	Mast / Fast / AUXi	-	-	Active / Inactive
TSX DEY 16D3	16	Mast / Fast / AUXi	-	-	Active / Inactive
TSX DEY 32D2K	32	Mast / Fast / AUXi	-	-	Active / Inactive
TSX DEY 32D3K	32	Mast / Fast / AUXi	-	-	Active / Inactive
TSX DEY 64D2K	64	Mast / Fast / AUXi	-	-	Active / Inactive
TSX DEY 16FK	16	Mast / Fast / AUXi	Normal or (1)	4 ms or (2)	Active / Inactive
TSX DMY 28FK	16 (inputs)	Mast / Fast / AUXi	Normal or (1)	4 ms or (2)	Active / Inactive
TSX PAY 262 TSX PAY 282	8 (inputs) 8 (inputs)	Mast / Fast / AUXi	-	-	Active / Inactive

Reference module	No. of inputs	Associated task (8 channel group)	Function (by channel)	Filter (by channel)	On. Power supply fault (16 channel group)
TSX DMY 28RFK	16 (inputs)	Mast / Fast / AUXi	-	4 ms or (2)	Active / Inactive
Legend:					
(1)	Latching of state 0 or 1, event processing if master crosses trigger in positive direction (RE), if master crosses trigger in negative direction (FE) or both at the same time.				
(2)	0.1 to 7.5 ms				

NOTE: Parameters in bold correspond to the parameters configured by default.

Discrete Output Parameters for 8 Channel Modules in Rack

At a Glance

The Discrete 8 channel output module includes parameters by channel or for the group of channels.

Parameters

The following table displays the parameters available for each 8 channels of the Discrete output module.

	8 channel group				Channel by channel
Reference module	Associated task	Reactivation	Fallback mode	On. Power supply fault	Fallback value
TSX DSY 08R4D	Mast / Fast / AUXi	Programmed / Automatic	Fallback / Maintenance	-	0 / 1
TSX DSY 08R5A	Mast / Fast / AUXi	Programmed / Automatic	Fallback / Maintenance	-	0 / 1
TSX DSY 08S5	Mast / Fast / AUXi	Programmed / Automatic	Fallback / Maintenance	-	0 / 1
TSX DSY 08T2	Mast / Fast / AUXi	Programmed / Automatic	Fallback / Maintenance	Active / Inactive	0 / 1
TSX DSY 08T22	Mast / Fast / AUXi	Programmed / Automatic	Fallback / Maintenance	Active / Inactive	0 / 1
TSX DSY 08T31	Mast / Fast / AUXi	Programmed / Automatic	Fallback / Maintenance	Active / Inactive	0 / 1
TSX DSY 08R5	Mast / Fast / AUXi	-	Fallback / Maintenance	-	0 / 1

NOTE: The parameters in bold correspond to the parameters configured by default.

Over 8 track modules on rack Discrete Output Parameter for Modules with more than 8 Channels on the Rack

At a Glance

Discrete output modules with more than 8 channels include parameters for channels or for the set of channels.

Parameters

The following table displays the parameters available for each discrete output module with more than 8 channels on the rack.

		8 channel group				Channel by channel
Reference module	Number of outputs	Task Group	Reactivation	Fallback mode	On. Power supply fault	Fallback value
TSX DSY 16S5	16	Mast / Fast / AUXi	Programmed / Automatic	Fallback / Maintenance	-	0 / 1
TSX DSY 16T2	16	Mast / Fast / AUXi	Programmed / Automatic	Fallback / Maintenance	Active / Inactive	
TSX DSY 16T3	16	Mast / Fast / AUXi	Programmed / Automatic	Fallback / Maintenance	Active / Inactive	0 / 1
TSX DSY 32T2K	32	Mast / Fast / AUXi	Programmed / Automatic	Fallback / Maintenance	Active / Inactive	0 / 1
TSX DSY 64T2K	64	Mast / Fast / AUXi	Programmed / Automatic	Fallback / Maintenance	Active / Inactive	0 / 1
TSX DSY 16R5	16	Mast / Fast / AUXi	-	Fallback / Maintenance	-	0 / 1
TSX DSY 16S4	16	Mast / Fast / AUXi	-	Fallback / Maintenance	-	0 / 1
TSX DMY 28FK	12 (outputs)	Mast / Fast / AUXi	Programmed / Automatic (1)	Fallback / Maintenance	Active / Inactive	0 / 1
TSX DMY 28RFK	12 (outputs)	Mast / Fast / AUXi	Programmed / Automatic (1)	Fallback / Maintenance	Active / Inactive	0 / 1 / Continued
TSX PAY 262 TSX PAY 282	2 (outputs) 4 (outputs)	Mast / Fast / AUXi	-	-	-	-
Legend:						
(1)	Reactivation is selected globally for the 12 output channels.					

NOTE: The parameters in bold correspond to the parameters configured by default.

34.3 Configuration of discrete parameters

Subject of this section

This section presents the installation of different discrete I/O channel configuration parameters.

What's in this Section?

This section contains the following topics:

Topic	Page
How to Modify the Task parameter of a Discrete module	413
How to Modify the External Power Supply Error Monitoring Parameter of a Discrete Module	414
How to Modify the Function Parameter of a Discrete Input Module	415
How to Modify the Filtering Parameter of a Discrete Input Module	417
How to modify the Fallback Mode Parameter of a Discrete Output Module	418
How to modify the Output Reactivation Parameter of a Discrete Module	419

How to Modify the Task parameter of a Discrete module

At a Glance

This parameter defines the processor task where input acquisitions and output updates are performed.

The task is defined for 8 consecutive channels in the case of on rack Discrete modules.

Possible choices are:

- The **MAST** task,
- The **FAST** task,
- The **AUX0/3** secondary tasks.

NOTE: The **AUX0/3** tasks are only available with a **TSX 57 5•4** processor.

NOTE: Modifying this parameter is only possible in offline mode.

Procedure

The following table shows how to define the type of task assigned to module channels.

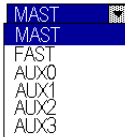
Step	Action
1	Open the desired module configuration screen.
2	For the desired channels group, click on the Task drop-down menu button of the General parameters zone. Result: A drop-down list appears. 
3	Choose the desired task.
4	Confirm the modification with the Edit → Validate menu command.

How to Modify the External Power Supply Error Monitoring Parameter of a Discrete Module

At a Glance

This parameter defines the state (activation or deactivation) of external power supply error monitoring.

It acts in groups of 16 consecutive channels.

Monitoring is active by default (box checked).

NOTE: For versions of discrete module < V2.0 (the version number is specified on the label on the side of the module), external supply monitoring cannot be disabled. Leave the function active. If monitoring is disabled inadvertently, after transfer and connection, the Diagnostics function will detect the error automatically. You can then change the setting in online mode.

Procedure

The following table shows how to disable or enable the external power supply fault monitoring function.

Step	Action
1	Open the desired module configuration screen.
2	Check the Supply monitor box in the General Parameters area.
3	Confirm the modification with the Edit → Enable menu command.

How to Modify the Function Parameter of a Discrete Input Module

At a Glance

This parameter defines the properties of the event input module **TSX DEY 16FK** and **TSX DMY 28FK**.

Possible parameter values are:

- Normal (no event associated with the channel),
- Channel by channel status latch (status on 0 or 1),
- Channel by channel event processing,
 - Event triggered on a rising edge (FM),
 - Event triggered on falling edge (FM),
 - Event triggered on rising and falling edges.

Event inputs are assigned an **(Evti)** process number. These numbers range from:

- **0 to 31** with a **TSX P57 1**** processor,
- **0 to 63** with a **PCI** processor or **TSX P57 2****, **TSX P57 3****, **TSX P57 4****,
- **0 to 127** with a **TSX P57 5•4** processor

If both transition types are selected on one channel, only one event number is assigned to the channel.

The most important event processing (Evti) is number 0, it can only be assigned to channel 0.

NOTE: The default event number is the first available in the list.

A number entered manually outside the tolerance range is not accepted when validating.

Adding, deleting, or changing the event number is not possible in online mode.

Instructions

The following table shows how to define parameters assigned to event inputs.

Step	Action
1	Open the desired module configuration screen.
2	Select the desired channel group.
3	Click in the cell of the Function column of the channel to be configured. Result: A drop-down menu appears.

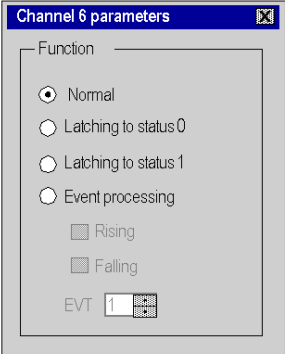
Step	Action
4	<p>Click on the drop-down menu arrow. Result: The Channel properties screen appears.</p> 
5	Select the desired function.
6	Enter the event number Evt.
7	Repeat the operation for each channel to be configured (from step 3).
8	Confirm the modification with the Edit → Validate menu command.

How to Modify the Filtering Parameter of a Discrete Input Module

At a Glance

This parameter defines the filtering period for the channel selected.

The default values are: 0.1 to 7.5 ms in 0.5 ms increments.

NOTE: Module filtering modification is possible in online mode (function available for Unity Pro versions greater than 1.0).

Procedure

The following table shows how to define the **Filtering** parameter.

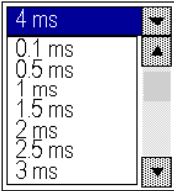
Step	Action
1	Open the desired module configuration screen.
2	Click on the arrow of the drop-down menu of the channel to be configured located in the Filter column. Result: The following list appears: 
3	Select the desired filtering time.
4	Confirm the modification with the Edit →Validate menu command.

How to modify the Fallback Mode Parameter of a Discrete Output Module

At a Glance

This parameter defines the Fallback mode assumed by the outputs when the controller moves to **Stop**, after a processor error, rack or inter-rack cable error.

Possible modes are:

Mode	Meaning
Fallback	Channels are set to 0 or 1 according to the defined fallback value for the corresponding 8 channel group.
Maintenance	The outputs retain their status they had before moving to Stop .
Continuous	This mode concerns only the TSX DMY 28RFK module. Event outputs are updated by the module: When this mode is selected, the event function remains active.

NOTE: The modification of this parameter is possible in online mode (function available for Unity Pro versions greater than 1.0).

Procedure

The following table shows the procedure for defining the fallback mode assigned to a channel group.

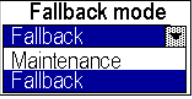
Step	Action
1	Open the desired module configuration screen.
2	For the desired channel group, click on the arrow of the Fall Back mode drop-down menu of the General parameters zone. Result: A drop-down list appears. 
3	Select the desired fallback mode.
4	For Fallback mode, configure each channel of the selected group. To do this, click on the drop-down menu arrow of the channel to be configured, located in the Fall Back Value column.
5	Click on the desired value (0 or 1).
6	Confirm the modification with the Edit → Validate menu command.

How to modify the Output Reactivation Parameter of a Discrete Module

At a Glance

This parameter defines the reactivation mode of disconnected outputs.

Possible modes are:

Mode	Meaning
Programmed	Reactivation is executed with a command from the PLC application or through the appropriate debug screen. Note: In order to avoid repeated reactivations, the module ensures automatically a 10 s delay between two reactivations.
Automatic	The reactivation is executed automatically every 10 s until the error disappears.

The reactivation mode is defined for 8 channel groups.

NOTE: The modification of this parameter is possible in online mode (function available for Unity Pro versions greater than 1.0).

Procedure

The following table shows the procedure for defining the module output channel reactivation mode.

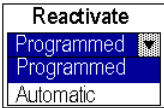
Step	Action
1	Open the desired module configuration screen.
2	For the desired channel group, click on the arrow of the Reactivate drop-down menu of the General parameters zone. Result: A drop-down list appears. 
3	Choose the desired reactivation.
4	Confirm the modification with the Edit → Validate menu command.

Description of the Discrete Specific-Application Language Objects

35

Aim of this Chapter

This chapter describes the language objects associated with Discrete specific applications from various IODDT.

What's in this Chapter?

This chapter contains the following sections:

Section	Topic	Page
35.1	Language Objects and IODDT	422
35.2	IODDTs of the Discrete modules	431

35.1 Language Objects and IODDT

Aim of this section

This section provides general information about language objects and IODDTs for Discrete.

What's in this Section?

This section contains the following topics:

Topic	Page
Description of the Discrete Function Objects Languages	423
Implicit Exchange Language Objects Associated with the Application-Specific Function	424
Explicit Exchange Language Objects Associated with the Application-Specific Function	425
Management of Exchanges and Reports with Explicit Objects	427

Description of the Discrete Function Objects Languages

General information

The Discrete modules have different IODDT groups.

The IODDTs are predefined by the manufacturer, they contain input/output languages objects belonging to a channel of a specific application module.

There are six IODDT types for the Discrete:

- T_DIS_IN_GEN,
- T_DIS_IN_STD,
- T_DIS_EVT,
- T_DIS_OUT_GEN,
- T_DIS_OUT_STD,
- T_DIS_OUT_REFLEX specific for the **TSX DMY 28RFK** reflex discrete module.

NOTE: IODDT variables can be created in two different ways:

- Using the **I/O objects** (see *Unity Pro, Operating Modes*) tab,
- Data Editor (see *Unity Pro, Operating Modes*).

Language objects types

In each IODDT is a set of language objects permitting the control and verification of their operation.

There are two types of language objects:

- **Implicit Exchanges Objects** , which are automatically exchanged at each cycle pass of the task associated to the module,
- **Explicit Exchanges Objects** , which are exchanged upon demand from the application, while using explicit exchange instructions.

Implicit exchanges concern the module's inputs/outputs: Measurement, information, and operation results.

Explicit exchanges enable module configuration and diagnosis.

Implicit Exchange Language Objects Associated with the Application-Specific Function

At a Glance

An integrated application-specific interface or the addition of a module automatically enhances the language objects application used to program this interface or module.

These objects correspond to the input/output images and software data of the module or integrated application-specific interface.

Reminders

The module inputs (%I and %IW) are updated in the PLC memory at the start of the task, the PLC being in RUN or STOP mode.

The outputs (%Q and %QW) are updated at the end of the task, only when the PLC is in RUN mode.

NOTE: When the task occurs in STOP mode, either of the following are possible, depending on the configuration selected:

- outputs are set to fallback position (fallback mode)
- outputs are maintained at their last value (maintain mode)

Figure

The following diagram shows the operating cycle of a PLC task (cyclical execution).

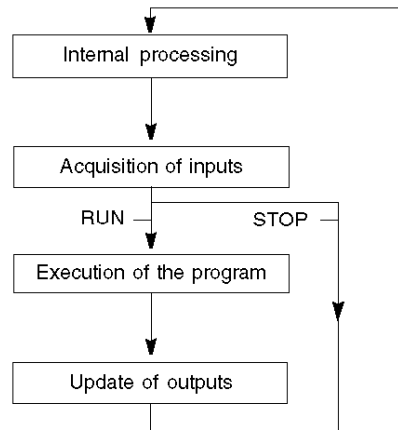

Explicit Exchange Language Objects Associated with the Application-Specific Function

Introduction

Explicit exchanges are performed at the user program's request using these instructions:

- READ_STS (*see Unity Pro, I/O Management, Block Library*) (read status words)
- WRITE_CMD (*see Unity Pro, I/O Management, Block Library*) (write command words)
- WRITE_PARAM (*see Unity Pro, I/O Management, Block Library*) (write adjustment parameters)
- READ_PARAM (*see Unity Pro, I/O Management, Block Library*) (read adjustment parameters)
- SAVE_PARAM (*see Unity Pro, I/O Management, Block Library*) (save adjustment parameters)
- RESTORE_PARAM (*see Unity Pro, I/O Management, Block Library*) (restore adjustment parameters)

These exchanges apply to a set of %MW objects of the same type (status, commands or parameters) that belong to a channel.

NOTE:

These objects can:

- provide information about the module (for example, type of channel fault)
- have command control of the module (for example, switch command)
- define the module's operating modes (save and restore adjustment parameters in the process of application)

NOTE: In order to avoid several simultaneous explicit exchanges for the same channel, it is necessary to test the value of the word EXCH_STS (%MW_{r.m.c.}0) of the IODDT associated to the channel before calling any EF addressing this channel.

General Principle for Using Explicit Instructions

The diagram below shows the different types of explicit exchanges that can be made between the application and module.

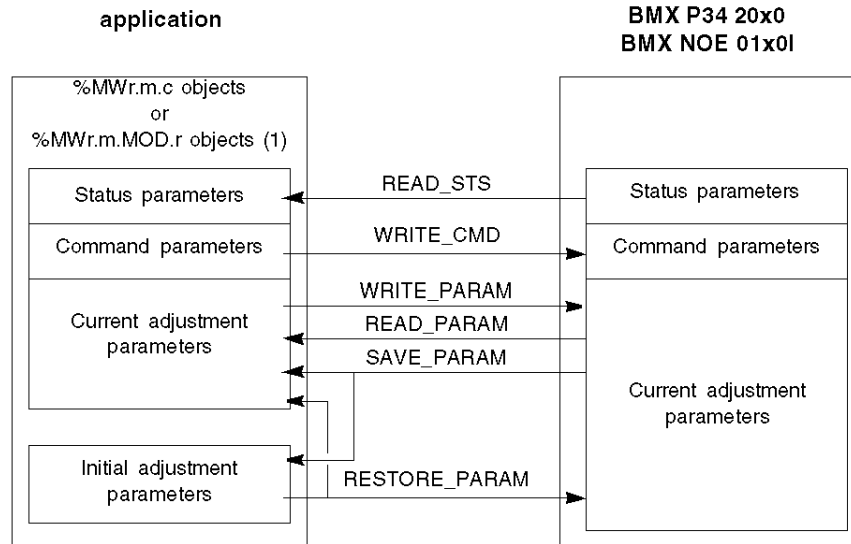

(1) Only with READ_STS and WRITE_CMD instructions.

Managing Exchanges

During an explicit exchange, it is necessary to check performance to ensure data is only taken into account when the exchange has been correctly executed.

To do this, two types of information is available:

- information concerning the exchange in progress (*see page 429*)
- the exchange report (*see page 430*)

The following diagram describes the management principle for an exchange.

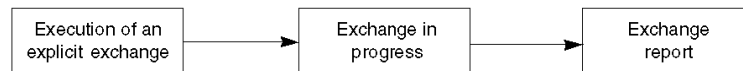

NOTE: In order to avoid several simultaneous explicit exchanges for the same channel, it is necessary to test the value of the word EXCH_STS (%MWr.m.c.0) of the IODDT associated to the channel before calling any EF addressing this channel.

Management of Exchanges and Reports with Explicit Objects

At a Glance

When data is exchanged between the PLC memory and the module, the module may require several task cycles to acknowledge this information. All IODDTs use two words to manage exchanges:

- EXCH_STS (%MW_{r.m.c.0}): exchange in progress
- EXCH_RPT (%MW_{r.m.c.1}): report

NOTE:

Depending on the localization of the module, the management of the explicit exchanges (%MW0.0.MOD.0.0 for example) will not be detected by the application:

- For in-rack modules, explicit exchanges are done immediately on the local PLC Bus and are finished before the end of the execution task. So, the READ_STS, for example, is always finished when the %MW0.0.mod.0.0 bit is checked by the application.
- For remote bus (Fipio for example), explicit exchanges are not synchronous with the execution task, so the detection is possible by the application.

Illustration

The illustration below shows the different significant bits for managing exchanges:

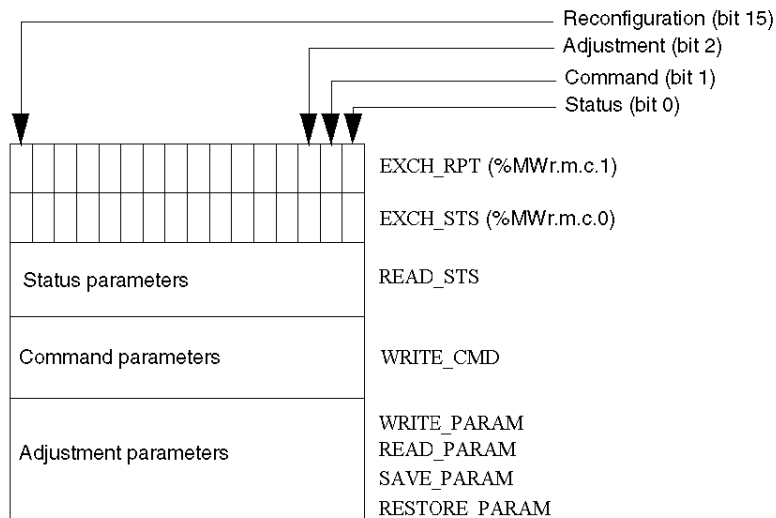

Description of Significant Bits

Each bit of the words `EXCH_STS` (`%MWr.m.c.0`) and `EXCH_RPT` (`%MWr.m.c.1`) is associated with a type of parameter:

- Rank 0 bits are associated with the status parameters:
 - The `STS_IN_PROGR` bit (`%MWr.m.c.0.0`) indicates whether a read request for the status words is in progress.
 - The `STS_ERR` bit (`%MWr.m.c.1.0`) specifies whether a read request for the status words is accepted by the module channel.
- Rank 1 bits are associated with the command parameters:
 - The `CMD_IN_PROGR` bit (`%MWr.m.c.0.1`) indicates whether command parameters are being sent to the module channel.
 - The `CMD_ERR` bit (`%MWr.m.c.1.1`) specifies whether the command parameters are accepted by the module channel.
- Rank 2 bits are associated with the adjustment parameters:
 - The `ADJ_IN_PROGR` bit (`%MWr.m.c.0.2`) indicates whether the adjustment parameters are being exchanged with the module channel (via `WRITE_PARAM`, `READ_PARAM`, `SAVE_PARAM`, `RESTORE_PARAM`).
 - The `ADJ_ERR` bit (`%MWr.m.c.1.2`) specifies whether the adjustment parameters are accepted by the module. If the exchange is correctly executed, the bit is set to 0.
- Rank 15 bits indicate a reconfiguration on channel `c` of the module from the console (modification of the configuration parameters + cold start-up of the channel).
- The `r`, `m` and `c` bits indicates the following elements:
 - the `r` bit represents the rack number.
 - The `m` bit represents the position of the module in the rack.
 - The `c` bit represents the channel number in the module.

NOTE: `r` represents the rack number, `m` the position of the module in the rack, while `c` represents the channel number in the module.

NOTE: Exchange and report words also exist at module level `EXCH_STS` (`%MWr.m.MOD`) and `EXCH_RPT` (`%MWr.m.MOD.1`) as per IODDT type `T_GEN_MOD`.

Example

Phase 1: Sending data by using the `WRITE_PARAM` instruction

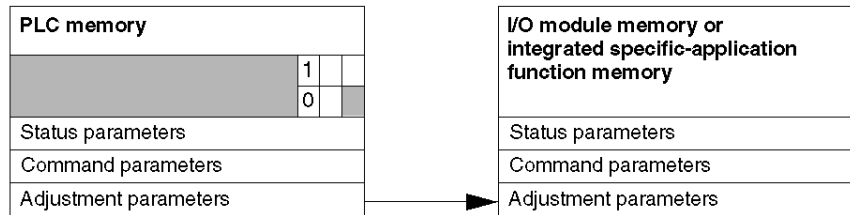

When the instruction is scanned by the PLC processor, the **Exchange in progress** bit is set to 1 in `%MWr.m.c`.

Phase 2: Analysis of the data by the I/O module and report.

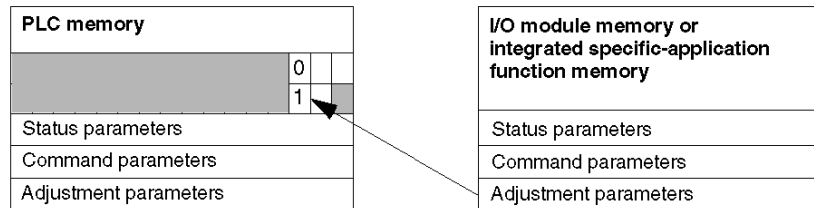

When the data is exchanged between the PLC memory and the module, acknowledgement by the module is managed by the `ADJ_ERR` bit (`%MWr.m.c.1.2`).

This bit makes the following reports:

- **0**: correct exchange
- **1**: faulty exchange)

NOTE: There is no adjustment parameter at module level.

Execution Indicators for an Explicit Exchange: EXCH_STS

The table below shows the control bits of the explicit exchanges: `EXCH_STS` (`%MWr.m.c.0`)

Standard symbol	Type	Access	Meaning	Address
STS_IN_PROGR	BOOL	R	Reading of channel status words in progress	<code>%MWr.m.c.0.0</code>
CMD_IN_PROGR	BOOL	R	Command parameters exchange in progress	<code>%MWr.m.c.0.1</code>

Standard symbol	Type	Access	Meaning	Address
ADJ_IN_PROGR	BOOL	R	Adjust parameters exchange in progress	%MWr.m.c.0.2
RECONF_IN_PROGR	BOOL	R	Reconfiguration of the module in progress	%MWr.m.c.0.15

NOTE: If the module is not present or is disconnected, explicit exchange objects (READ_STS for example) are not sent to the module (STS_IN_PROG (%MWr.m.c.0.0) = 0), but the words are refreshed.

Explicit Exchange Report: EXCH_RPT

The table below shows the report bits: EXCH_RPT (%MWr.m.c.1)

Standard symbol	Type	Access	Meaning	Address
STS_ERR	BOOL	R	Error reading channel status words (1 = failure)	%MWr.m.c.1.0
CMD_ERR	BOOL	R	Error during a command parameter exchange (1 = failure)	%MWr.m.c.1.1
ADJ_ERR	BOOL	R	Error during an adjust parameter exchange (1 = failure)	%MWr.m.c.1.2
RECONF_ERR	BOOL	R	Error during reconfiguration of the channel (1 = failure)	%MWr.m.c.1.15

Counting Module Use

The following table describes the steps realised between a Counting Module and the system after a power-on.

Step	Action
1	Power on.
2	The system sends the configuration parameters.
3	The system sends the adjust parameters by WRITE_PARAM method. Note: When the operation is finished, the bit %MWr.m.c.0.2 switches to 0.

If, in the beginning of your application, you use a WRITE_PARAM command, you must wait until the bit %MWr.m.c.0.2 switches to 0.

35.2 IODDTs of the Discrete modules

Aim of this section

This section presents the different IODDT languages and objects related to Discrete input/output modules.

What's in this Section?

This section contains the following topics:

Topic	Page
Details about T_DIS_IN_GEN Type IODDT Implicit Object Exchange	432
Details about T_DIS_IN_STD Type IODDT Implicit Object Exchange	433
Details about T_DIS_IN_STD Type IODDT Explicit Object Exchange	434
Details about T_DIS_EVT Type IODDT Implicit Object Exchange	436
Details about T_DIS_EVT Type IODDT Explicit Object Exchange	437
Details about T_DIS_OUT_GEN Type IODDT Implicit Object Exchange	439
Details about T_DIS_OUT_STD Type IODDT Implicit Object Exchange	440
Details about T_DIS_OUT_STD Type IODDT Explicit Object Exchange	441
Details about T_DIS_OUT_REFLEX Type IODDT Implicit Object Exchange	443
Details for T_DIS_OUT_REFLEX Type IODDT Explicit Object Exchange	444
Details of the Language Objects of the T_GEN_MOD-Type IODDT	446
Security Modules Language Objects Details	447

Details about T_DIS_IN_GEN Type IODDT Implicit Object Exchange

At a Glance

This section describes T_DIS_IN_GEN type IODDT Implicit Object Exchange that applies to all discrete input modules.

Input flag

The following table presents the VALUE (%I.r.m.c) bit meaning.

Standard symbol	Type	Access	Meaning	Number
VALUE	EBOOL	R	Indicates that the output of the sensor commanding the input is activated for c input channel.	%I.r.m.c

Error Bit

The following table describes the CH_ERROR (%I.r.m.c.ERR) bit meaning.

Standard symbol	Type	Access	Meaning	Number
CH_ERROR	BOOL	R	Indicate that c input channel is at fault.	%I.r.m.c.ERR

Details about T_DIS_IN_STD Type IODDT Implicit Object Exchange

At a Glance

This section presents T_DIS_IN_STD type IODDT Implicit Object Exchange that applies to discrete input and reflex input modules.

Input flag

The following table shows the VALUE (%lr.m.c) bit meaning.

Standard symbol	Type	Access	Meaning	Number
VALUE	EBOOL	R	Indicates that the output of the sensor controlling the input is activated for the c input channel track.	%lr.m.c

Error Bit

The following table provides the CH_ERROR (%lr.m.c.ERR) bit meaning.

Standard symbol	Type	Access	Meaning	Number
CH_ERROR	BOOL	R	Indicates that c input channel is at fault.	%lr.m.c.ERR

Details about T_DIS_IN_STD Type IODDT Explicit Object Exchange

At a Glance

This section describes T_DIS_IN_STD type IODDT Explicit Object Exchange that applies to discrete input and reflex input modules. It regroups word type objects, which bits have a particular meaning. These objects are explained in detail below.

Example of declaring a variable:

```
IODDT_VAR1 of type T_DIS_INT_STD.
```

NOTE: Generally, bit meaning is provided for state 1 of that bit. In specific cases each bit state is explained.

NOTE: Not all bits are used.

Explicit exchange execution indicators: EXCH_STS

The following table shows exchange control bit meanings for channel EXCH_STS (%MWr.m.c.0).

Standard symbol	Type	Access	Meaning	Number
STS_IN_PROGR	BOOL	R	Status words reading for the channel in progress.	%MWr.m.c.0.0
CMD_IN_PROGR	BOOL	R	Command parameters exchange in progress.	%MWr.m.c.0.1

Explicit exchange report: EXCH_RPT

The table below shows EXCH_RPT (%MWr.m.c.1) report bit meanings.

Standard symbol	Type	Access	Meaning	Number
STS_ERR	BOOL	R	Channel status word reading error (1 = failure).	%MWr.m.c.1.0
CMD_ERR	BOOL	R	Error during command parameter exchange (1 = failure).	%MWr.m.c.1.1

Standard channel faults: CH_FLT

The table below shows the CH_FLT (%MWr.m.c.2) status word bit meanings. The reading is performed by a READ_STS (IODDT_VAR1).

Standard symbol	Type	Access	Meaning	Number
TRIP	BOOL	R	External error: Tripped.	%MWr.m.c.2.0
FUSE	BOOL	R	External error: Fuse.	%MWr.m.c.2.1
BLK	BOOL	R	Terminal block error.	%MWr.m.c.2.2
EXT_PS_FLT	BOOL	R	External supply fault.	%MWr.m.c.2.3
INTERNAL_FLT	BOOL	R	Internal error: H.S. module	%MWr.m.c.2.4
CONF_FLT	BOOL	R	Hardware or software configuration error.	%MWr.m.c.2.5

Standard symbol	Type	Access	Meaning	Number
COM_FLT	BOOL	R	Problem communicating with the PLC.	%MWr.m.c.2.6
SHORT_CIRCUIT	BOOL	R	External error: Short-circuit on a channel.	%MWr.m.c.2.8
LINE_FLT	BOOL	R	External error: Line fault.	%MWr.m.c.2.9

Status word: CH_CMD

The table below shows the CH_CMD (%MWr.m.c.3) status word bit meanings. The command is executed by a WRITE_CMD (IODDT_VAR1).

Standard symbol	Type	Access	Meaning	Number
PS_CTRL_DIS	BOOL	R/W	Disable control of the external supply.	%MWr.m.c.3.1
PS_CTRL_EN	BOOL	R/W	Enable control of the external supply.	%MWr.m.c.3.2

Details about T_DIS_EVT Type IODDT Implicit Object Exchange

At a Glance

The following tables show IODDT of type T_DIS_EVT implicit exchanges objects that apply to Discrete event input modules.

Input flag

The following table presents the VALUE (%lr.m.c) bit meaning.

Standard symbol	Type	Access	Meaning	Number
VALUE	EBOOL	R	Indicates that the output of the sensor controlling the input is activated for the c input channel track.	%lr.m.c

Error Bit

The following table presents the CH_ERROR (%lr.m.c.ERR) bit meaning.

Standard symbol	Type	Access	Meaning	Number
CH_ERROR	BOOL	R	Indicates that c input channel is at fault.	%lr.m.c.ERR

Event flag: EVT_STS

The following table shows EVT_STS (%lWr.m.c.0) word bit meanings.

Standard symbol	Type	Access	Meaning	Number
RE_EVT	BOOL	R	Indicate that event processing is configured for positive transition.	%lWr.m.c.0.0
FE_EVT	BOOL	R	Indicate that event processing is configured for negative transition.	%lWr.m.c.0.1

Event flag: EVT_MASK

The following table presents the EVT_STS (%lr.m.c) bit meaning.

Standard symbol	Type	Access	Meaning	Number
EVT_MASK	BOOL	R/W	Enables you to mask/unmask the event assigned to the channel.	%QWr.m.c.0.0

Details about T_DIS_EVT Type IODDT Explicit Object Exchange

At a Glance

This section shows the IODDT of type `T_DIS_EVT` explicit exchange objects that are valid for Discrete event input modules. It regroups word type objects, which bits have a particular meaning. These objects are explained in detail below.

Example of declaring a variable:

```
IODDT_VAR1 of type T_DIS_EVT.
```

NOTE: Generally, bit meaning is provided for state 1 of that bit. In specific cases each bit state is explained.

NOTE: Not all bits are used.

Explicit exchange execution indicators: EXCH_STS

The following table shows exchange control bit meanings for channel `EXCH_STS` (%MWr.m.c.0).

Standard symbol	Type	Access	Meaning	Number
<code>STS_IN_PROGR</code>	BOOL	R	Status words reading for the channel in progress.	%MWr.m.c.0.0
<code>CMD_IN_PROGR</code>	BOOL	R	Command parameters exchange in progress.	%MWr.m.c.0.1

Explicit exchange report: EXCH_RPT

The table below shows `EXCH_RPT` (%MWr.m.c.1) report bit meanings.

Standard symbol	Type	Access	Meaning	Number
<code>STS_ERR</code>	BOOL	R	Channel status word reading error (1 = failure).	%MWr.m.c.1.0
<code>CMD_ERR</code>	BOOL	R	Error during command parameter exchange (1 = failure).	%MWr.m.c.1.1

Standard channel faults, CH_FLT

The table below shows the `CH_FLT` (%MWr.m.c.2) status word bit meanings. The reading is performed by a `READ_STS` (`IODDT_VAR1`).

Standard symbol	Type	Access	Meaning	Number
<code>TRIP</code>	BOOL	R	External error: Tripped.	%MWr.m.c.2.0
<code>FUSE</code>	BOOL	R	External error: Fuse.	%MWr.m.c.2.1
<code>BLK</code>	BOOL	R	Terminal block error.	%MWr.m.c.2.2
<code>EXT_PS_FLT</code>	BOOL	R	External supply fault.	%MWr.m.c.2.3
<code>INTERNAL_FLT</code>	BOOL	R	Internal error: H.S. module	%MWr.m.c.2.4
<code>CONF_FLT</code>	BOOL	R	Hardware or software configuration error.	%MWr.m.c.2.5

Standard symbol	Type	Access	Meaning	Number
COM_FLT	BOOL	R	Problem communicating with the PLC.	%MWr.m.c.2.6
SHORT_CIRCUIT	BOOL	R	External error: Short-circuit on a channel.	%MWr.m.c.2.8
LINE_FLT	BOOL	R	External error: Line fault.	%MWr.m.c.2.9

Status word: CH_CMD

The table below shows the CH_CMD (%MWr.m.c.3) status word bit meanings. The command is executed by a WRITE_CMD (IODDT_VAR1).

Standard symbol	Type	Access	Meaning	Number
PS_CTRL_DIS	BOOL	R/W	Inhibit control of external supply.	%MWr.m.c.3.1
PS_CTRL_EN	BOOL	R/W	Validation of the external supply control.	%MWr.m.c.3.2

Details about T_DIS_OUT_GEN Type IODDT Implicit Object Exchange

At a Glance

This section presents T_DIS_OUT_GEN type IODDT Implicit Object Exchange that applies to discrete output modules.

Output flag

The following table presents the VALUE (%Qr.m.c) bit meaning.

Standard symbol	Type	Access	Meaning	Number
VALUE	EBOOL	R/W	Indicates that the c output channel is active.	%Qr.m.c

Error Bit

The following table presents the CH_ERROR (%lr.m.c.ERR) bit meaning.

Standard symbol	Type	Access	Meaning	Number
CH_ERROR	BOOL	R	Indicates that c input channel is at fault.	%lr.m.c.ERR

Details about T_DIS_OUT_STD Type IODDT Implicit Object Exchange

At a Glance

This section presents T_DIS_OUT_STD type IODDT Implicit Object Exchange that applies to discrete output modules.

Output flag

The following table presents the VALUE (%Qr.m.c) bit meaning.

Standard symbol	Type	Access	Meaning	Number
VALUE	EBOOL	R/W	Indicates that the c output channel is active.	%Qr.m.c

Error Bit

The following table presents the CH_ERROR (%lr.m.c.ERR) bit meaning.

Standard symbol	Type	Access	Meaning	Number
CH_ERROR	BOOL	R	Indicates that c output channel is at fault.	%lr.m.c.ERR

Details about T_DIS_OUT_STD Type IODDT Explicit Object Exchange

At a Glance

This section presents T_DIS_OUT_STD type IODDT Explicit Object Exchange that applies to discrete output modules. It regroups word type objects, which bits have a particular meaning. These objects are explained in detail below.

Example of declaring a variable:

```
IODDT_VAR1 of type T_DIS_OUT_STD.
```

NOTE: Generally, bit meaning is provided for state 1 of that bit. In specific cases each bit state is explained.

NOTE: Not all bits are used.

Explicit exchange execution indicators: EXCH_STS

The following table shows exchange control bit meanings for channel EXCH_STS (%MWr.m.c.0).

Standard symbol	Type	Access	Meaning	Number
STS_IN_PROGR	BOOL	R	Status words reading for the channel in progress.	%MWr.m.c.0.0
CMD_IN_PROGR	BOOL	R	Command parameters exchange in progress.	%MWr.m.c.0.1

Explicit exchange report: EXCH_RPT

The table below shows EXCH_RPT (%MWr.m.c.1) report bit meanings.

Standard symbol	Type	Access	Meaning	Number
STS_ERR	BOOL	R	Channel status word reading error (1 = failure).	%MWr.m.c.1.0
CMD_ERR	BOOL	R	Error during command parameter exchange (1 = failure).	%MWr.m.c.1.1

Standard channel faults: CH_FLT

The table below shows the CH_FLT (%MWr.m.c.2) status word bit meanings. The reading is performed by a READ_STS (IODDT_VAR1).

Standard symbol	Type	Access	Meaning	Number
TRIP	BOOL	R	External error: Tripped.	%MWr.m.c.2.0
FUSE	BOOL	R	External error: Fuse.	%MWr.m.c.2.1
BLK	BOOL	R	Terminal block error.	%MWr.m.c.2.2
EXT_PS_FLT	BOOL	R	External supply fault.	%MWr.m.c.2.3
INTERNAL_FLT	BOOL	R	Internal error: H.S. module	%MWr.m.c.2.4
CONF_FLT	BOOL	R	Hardware or software configuration error.	%MWr.m.c.2.5

Standard symbol	Type	Access	Meaning	Number
COM_FLT	BOOL	R	Communicating with automaton fault.	%MWr.m.c.2.6
SHORT_CIRCUIT	BOOL	R	External error: Short-circuit on a channel.	%MWr.m.c.2.8
LINE_FLT	BOOL	R	External error: Line fault.	%MWr.m.c.2.9

Status word: CH_CMD

The table below shows the CH_CMD (%MWr.m.c.3) status word bit meanings. The command is executed by a WRITE_CMD (IODDT_VAR1).

Standard symbol	Type	Access	Meaning	Number
REAC_OUT	BOOL	R/W	Reactivation of tripped outputs (protected outputs).	%MWr.m.c.3.0
PS_CTRL_DIS	BOOL	R/W	Inhibit control of external supply.	%MWr.m.c.3.1
PS_CTRL_EN	BOOL	R/W	Validation of the external supply control.	%MWr.m.c.3.2

NOTE: This object is specific to output modules with reactivation.

Details about T_DIS_OUT_REFLEX Type IODDT Implicit Object Exchange

At a Glance

The following tables show IODDT of type T_DIS_OUT_REFLEX implicit exchanges objects that apply to Discrete output reflex modules.

Error Bit

The following table presents the CH_ERROR (%lr.m.c.ERR) bit meaning.

Standard symbol	Type	Access	Meaning	Number
CH_ERROR	BOOL	R	Indicates that c channel is at fault.	%lr.m.c.ERR

Status bit

The following table presents PHYS_OUT (%lr.m.c.0) and AUX_OUT (%lr.m.c.1) status bit meanings.

Standard symbol	Type	Access	Meaning	Number
PHYS_OUT	EBOOL	R	Module physical output status bit.	%lr.m.c.0
AUX_OUT	EBOOL	R	Module auxiliary output status bit.	%lr.m.c.1

Event flag: EVT_STS

The following table shows EVT_STS (%lWr.m.c.0) word bit meanings.

Standard symbol	Type	Access	Meaning	Number
RE_EVT	BOOL	R	Indicate that event processing is configured for positive transition.	%lWr.m.c.0.0
FE_EVT	BOOL	R	Indicate that event processing is configured for negative transition.	%lWr.m.c.0.1

Control bit

The following table presents the CMD_OUT (%Qr.m.c) control bit meaning.

Standard symbol	Type	Access	Meaning	Number
CMD_OUT	EBOOL	R/W	Indicate that c channel is active.	%Qr.m.c

Event flag: EVT_MASK

The following table presents the EVT_MASK (%QWr.m.c.0.0) bit meaning.

Standard symbol	Type	Access	Meaning	Number
EVT_MASK	BOOL	R/W	Enables you to mask/unmask the event assigned to the channel.	%QWr.m.c.0.0

Details for T_DIS_OUT_REFLEX Type IODDT Explicit Object Exchange

At a Glance

This section shows the IODDT of type `T_DIS_OUT_REFLEX` explicit exchange objects that apply to Discrete reflex output modules. It regroups word type objects, which bits have a particular meaning. These objects are explained in detail below.

Example of declaring a variable:

```
IODDT_VAR1 of type T_DIS_OUT_REFLEX.
```

NOTE: Generally, bit meaning is provided for state 1 of that bit. In specific cases each bit state is explained.

NOTE: Not all bits are used.

Explicit exchange execution indicators: EXCH_STS

The following table shows exchange control bit meanings for channel `EXCH_STS` (%MWr.m.c.0).

Standard symbol	Type	Access	Meaning	Number
STS_IN_PROGR	BOOL	R	Status words reading for the channel in progress.	%MWr.m.c.0.0
CMD_IN_PROGR	BOOL	R	Command parameters exchange in progress.	%MWr.m.c.0.1
ADJ_IN_PROGR	BOOL	R	Adjust parameters exchange in progress.	%MWr.m.c.0.2

Explicit exchange report: EXCH_RPT

The table below shows `EXCH_RPT` (%MWr.m.c.1) report bit meanings.

Standard symbol	Type	Access	Meaning	Number
STS_ERR	BOOL	R	Channel status word reading error (1 = failure).	%MWr.m.c.1.0
CMD_ERR	BOOL	R	Error during command parameter exchange (1 = failure).	%MWr.m.c.1.1
ADJ_ERR	BOOL	R	Fault at the time of a adjusting parameter exchange.	%MWr.m.c.1.2

Standard channel faults: CH_FLT

The table below shows the `CH_FLT` (%MWr.m.c.2) status word bit meanings. The reading is performed by a `READ_STS` (IODDT_VAR1).

Standard symbol	Type	Access	Meaning	Number
TRIP	BOOL	R	External error: Tripped.	%MWr.m.c.2.0
FUSE	BOOL	R	External error: Fuse.	%MWr.m.c.2.1
BLK	BOOL	R	Terminal block error.	%MWr.m.c.2.2

Standard symbol	Type	Access	Meaning	Number
EXT_PS_FLT	BOOL	R	External supply fault.	%MWr.m.c.2.3
INTERNAL_FLT	BOOL	R	Internal error: H.S. module	%MWr.m.c.2.4
CONF_FLT	BOOL	R	Hardware or software configuration error.	%MWr.m.c.2.5
COM_FLT	BOOL	R	Problem communicating with the PLC.	%MWr.m.c.2.6
SHORT_CIRCUIT	BOOL	R	External error: Short-circuit on a channel.	%MWr.m.c.2.8
LINE_FLT	BOOL	R	External error: Line fault.	%MWr.m.c.2.9

Status word: CH_CMD

The table below shows the CH_CMD (%MWr.m.c.3) status word bit meanings. The command is executed by a WRITE_CMD (IODDT_VAR1).

Standard symbol	Type	Access	Meaning	Number
REAC_OUT	BOOL	R/W	Reactivation of tripped outputs (protected outputs).	%MWr.m.c.3.0
PS_CTRL_DIS	BOOL	R/W	Inhibit control of external supply.	%MWr.m.c.3.1
PS_CTRL_EN	BOOL	R/W	Validation of the external supply control.	%MWr.m.c.3.2

NOTE: This object is specific to output modules with reactivation.

Output specific objects: VALUE1 and VALUE2

The following table presents word meanings specific for VALUE1 and VALUE2 reflex output.

Standard symbol	Type	Access	Meaning	Number
VALUE1	INT	R/W	Contains the first internal value of the function block.	%MWr.m.c.4
VALUE2	INT	R/W	Contains the second internal value of the function block.	%MWr.m.c.5

Details of the Language Objects of the T_GEN_MOD-Type IODDT

At a Glance

All the modules of Premium PLCs have an associated IODDT of type T_GEN_MOD.

Observations

- In general, the meaning of the bits is given for bit status 1. In specific cases an explanation is given for each status of the bit.
- Not all bits are used.

List of Objects

The table below presents the objects of the IODDT:

Standard symbol	Type	Access	Meaning	Address
MOD_ERROR	BOOL	R	Module error bit	%I.r.m.MOD.ERR
EXCH_STS	INT	R	Module exchange control word.	%MWr.m.MOD.0
STS_IN_PROGR	BOOL	R	Reading of status words of the module in progress.	%MWr.m.MOD.0.0
EXCH_RPT	INT	R	Exchange report word.	%MWr.m.MOD.1
STS_ERR	BOOL	R	Fault when reading module status words.	%MWr.m.MOD.1.0
MOD_FLT	INT	R	Internal error word of the module.	%MWr.m.MOD.2
MOD_FAIL	BOOL	R	Internal error, module failure.	%MWr.m.MOD.2.0
CH_FLT	BOOL	R	Faulty channel(s).	%MWr.m.MOD.2.1
BLK	BOOL	R	Terminal block fault.	%MWr.m.MOD.2.2
CONF_FLT	BOOL	R	Hardware or software configuration fault.	%MWr.m.MOD.2.5
NO_MOD	BOOL	R	Module missing or inoperative.	%MWr.m.MOD.2.6
EXT_MOD_FLT	BOOL	R	Internal error word of the module (Fipio extension only).	%MWr.m.MOD.2.7
MOD_FAIL_EXT	BOOL	R	Internal fault, module unserviceable (Fipio extension only).	%MWr.m.MOD.2.8
CH_FLT_EXT	BOOL	R	Faulty channel(s) (Fipio extension only).	%MWr.m.MOD.2.9
BLK_EXT	BOOL	R	Terminal block fault (Fipio extension only).	%MWr.m.MOD.2.10
CONF_FLT_EXT	BOOL	R	Hardware or software configuration fault (Fipio extension only).	%MWr.m.MOD.2.13
NO_MOD_EXT	BOOL	R	Module missing or inoperative (Fipio extension only).	%MWr.m.MOD.2.14

Security Modules Language Objects Details

At a glance

This section presents the language objects that apply to input/output security modules **TSX PAY 262** and **TSX PAY 282**. These objects are not integrated in the IODDT linked to the Discrete modules.

NOTE: Generally, bit meaning is provided for state 1 of that bit. In specific cases each bit state is explained.

NOTE: Not all bits are used.

Progress indicator

The following table presents meaning of the %I.r.m.c.0 to 27 bits.

Number	Type	Access	Meaning
%I.r.m.c.0 to 23	EBOOL	R	24 input status words reading, 12 purge button or position switches status picture.
%I.r.m.c.24	EBOOL	R	Input reading, validation.
%I.r.m.c.25	EBOOL	R	Loop track reading.
%I.r.m.c.26	EBOOL	R	Security output command reading.
%I.r.m.c.27	EBOOL	R	Power supply presence on the security chain.

Error Bit

The following table presents the %I.r.m.MOD.ERR error bit meanings.

Number	Type	Access	Meaning
%I.r.m.MOD.ERR	BOOL	R	External module supply monitoring.

Debugging of discrete modules

36

Aim of this Section

This section describes the Debugging aspect of the installation of the discrete specific application.

What's in this Chapter?

This chapter contains the following topics:

Topic	Page
Introduction to the Debugging function of a discrete module	450
Description of the debug screen of a discrete module	451
How to access the forcing/unforcing function	453
How to access the SET and RESET commands	454
How to access the masking/unmasking of an event function	455
How to Access the Reactivation of Outputs Command	456
Applied outputs of a discrete module	457

Introduction to the Debugging function of a discrete module

Introduction

The Debugging function allows you, for each discrete input/output module of the application, to view the parameters of each of its channels (state of the channel, filter value, etc.) and to access the diagnostics and adjust modes of the selected channel (forcing of the channel, masking of the channel, etc.).

The function also gives access to module diagnostics in the event of a fault.

NOTE: this function is only available in online mode.

Description of the debug screen of a discrete module

At a Glance

The debug screen (see *Unity Pro, Operating Modes*) shows, in real time, the value and state of each channel of the selected module. It also allows access to the channel commands (forcing of the input or output value, reactivation of outputs, etc.).

Illustration

The figure below shows a sample debug screen.

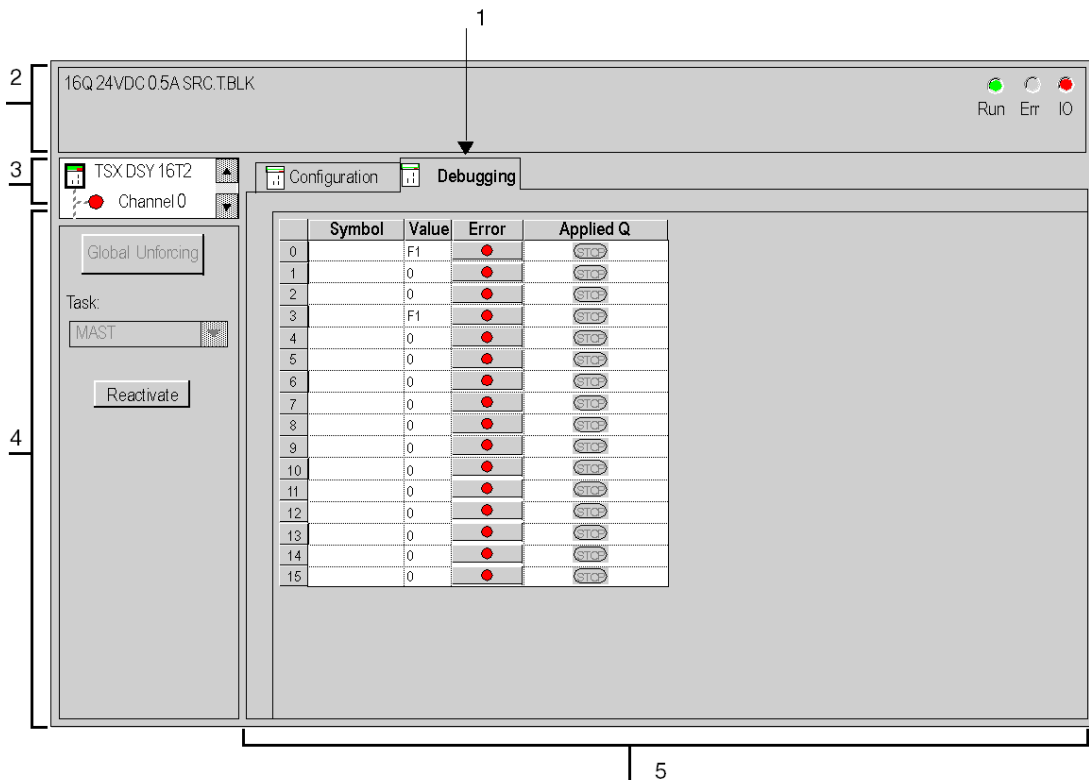

Description

The following table shows the various parts of the debug screen and their functions.

Address	Element	Function
1	Tabs	The tab in the foreground indicates the current mode (Debug for this example). Every mode can be selected using the respective tab. <ul style="list-style-type: none"> ● Debug only accessible in online mode, ● Adjust mode only available for the TSX DMY 28RFX (see page 468) module, ● Configuration.
2	Module zone	Specifies the abbreviated heading of the module. In the same zone, there are 3 display LEDs giving information on the module's operating mode: <ul style="list-style-type: none"> ● RUN indicates the module's operating mode, ● ERR signals a fault within the module, ● I/O signals a fault outside the module or an application fault.
3	Channel field	Is used: <ul style="list-style-type: none"> ● By clicking on the reference number, to display the tabs: <ul style="list-style-type: none"> ● Description which gives the characteristics of the device. ● I/O Objects (see <i>Unity Pro, Operating Modes</i>) which is used to presymbolize the input/output objects. ● Fault which shows the device faults (in online mode). ● To select the channel, ● To display the Symbol, name of the channel defined by the user (using the variable editor).
4	General parameters field	Specifies the parameters of the channel: <ul style="list-style-type: none"> ● Function: specifies the function configured. This heading is frozen. ● Task: specifies the MAST or FAST or AUX0/3 task configured. This heading is frozen. Specifies the parameters of the channel: <ul style="list-style-type: none"> ● Function: the Global unforcing button provides direct access to the global unforcing of channels function. ● Task: specifies the MAST or FAST or AUX0/3 task configured. This heading is frozen.
5	Current parameters field	This field displays the state of inputs and outputs and the various current parameters. For each channel, there are four columns: <ul style="list-style-type: none"> ● Symbol displays the symbol associated with the channel when it has been defined by the user (using the variable editor), ● Value displays the state of each channel of the module, ● Error provides direct access to channel by channel diagnostics when these are faulty (indicated by the LED built into the diagnostics access, which turns red). ● Applied outputs to indicate the output fallback (see page 457) position.

How to access the forcing/unforcing function

At a Glance

This function allows you to modify the state of all or part of the channels of a module. The state of a forced output is frozen and can only be modified by the application after unforcing.

NOTE: However, in the event of a fault leading to output fallback, the state of these outputs -assumes the value defined when configuring the Fallback mode (see page 418) parameter.

The various commands available are :

- for one or more channels :
 - force to 1,
 - force to 0,
 - unforcing (when the channel or channels selected are forced),
- for all the channels of a module (when at least one channel is forced) :
 - global unforcing of channels.

Procedure

The following table shows the procedure for forcing or unforcing all or part of the channels of a module.

Step	Action for one channel	Action for all channels
1	Access the module's debug screen.	
2	In the Value column, right-click the cell of the required channel.	Click on the Global unforcing button found in the general parameters field.
3	Select the required function: <ul style="list-style-type: none"> ● forcing to 0, ● forcing to 1. 	-

How to access the SET and RESET commands

At a Glance

These commands are used to change the state of a module's outputs to 0 (**RESET**) or 1 (**SET**).

NOTE: the state of the output affected by one of these commands is temporary and can be modified at any time by the application when the PLC is in **RUN**.

Procedure

The table below shows the procedure for assigning the value 0 or 1 to all or part of the channels of a module.

Step	Action for one channel
1	Access the module's debug screen.
2	In the Value column, right-click the cell of the required channel.
3	Select the desired function. <ul style="list-style-type: none">● Set,● Reset.

How to access the masking/unmasking of an event function

At a Glance

This function is used to "inhibit" or reestablish the processing associated with the input or output channel that caused the event.

The various commands available are :

- **Mask** (masks events),
- **Unmask** (cancels the masking of events).

NOTE: if one or more events occur whilst in the "inhibited" state, the associated processing operations are lost.

Procedure

The following table shows the procedure for masking or unmasking all or part of the channels configured in event processing.

Step	Action for one or more channels	Action for all the configured channels of the modules of the application (1)
1	Access the module's debug screen.	Access the CPU debug screen.
2	In the Status column, right-click the cell of the required channel.	Click on the Enable/Disable button situated in the Events field.
3	Select the desired function.	-
Key:		
(1)	Global masking/unmasking can also be carried out by: <ul style="list-style-type: none"> ● the MASKEVT() instruction, ● the UNMASKEVT() instruction, ● the system bit %S38. 	

How to Access the Reactivation of Outputs Command

At a Glance

When a fault has caused a tripped output, this command is used to reactivate the output if no fault remains at its terminals.

Reset is defined by a group of 8 channels. It has no effect on an inactive channel or channel without a fault.

Procedure

The following table shows the procedure for reactivating tripped outputs.

Step	Action
1	Access the module's debugging screen.
2	For the chosen group of channels, click on the Reactivate button situated in the General parameters field.

Applied outputs of a discrete module

At a Glance

This check (red Stop LED lit) informs the user that a given group of output channels is not correctly applied by the PLC (fallback status).

The possible causes are:

- processor fault,
- rack fault,
- inter-rack link fault.

Diagnostic of discrete modules

37

Aim of this Section

This section describes the Diagnostic aspect in the implementation of the discrete specific application.

What's in this Chapter?

This chapter contains the following topics:

Topic	Page
How to access the Diagnostics function of a discrete module	460
How to access the Channel Diagnostics function of a discrete module	462

How to access the Diagnostics function of a discrete module

At a Glance

The Module diagnostics module displays current errors, where these exist, classed according to their category :

- **internal faults:**
 - module failures,
 - self-test running,
- **external faults:**
 - terminal block fault,
- **other faults:**
 - configuration fault,
 - module missing or off,
 - faulty channel(s) (*see page 462*).

A module fault is indicated when certain LEDS change to red, such as :

- in the configuration editor at rack level :
 - the LED of the rack number,
 - the LED of the slot number of the module on the rack.
- in the configuration editor at module level :
 - the **I/O** LED according to the type of fault,
 - the **Channel** LED in the **Channel** field,
 - the Fault tab.

Procedure

The following table shows the procedure for accessing the Module fault screen.

Step	Action
1	Access the module's debug screen.
2	<p>Click on the module reference in the channel zone and select the Fault command. Result: The list of module faults appears.</p>  <p>Note: When a configuration fault occurs, in the event of major failure or absence of the module, access to the module diagnostics screen is not possible. The following message then appears on the screen: The module is not present or different from the one configured in this position.</p>

How to access the Channel Diagnostics function of a discrete module

At a Glance

The Channel diagnostics module displays current errors, where these exist, classed according to their category :

- **internal faults** :
 - channel failure,
- **external faults** :
 - link or sensor supply fault,
- **other faults** :
 - terminal block fault,
 - configuration fault,
 - communication fault.

A channel error appears in the **Debug** tab when the  LED, located in the **Error** column, turns red.

Procedure

The following table shows the procedure for accessing the Channel fault screen.

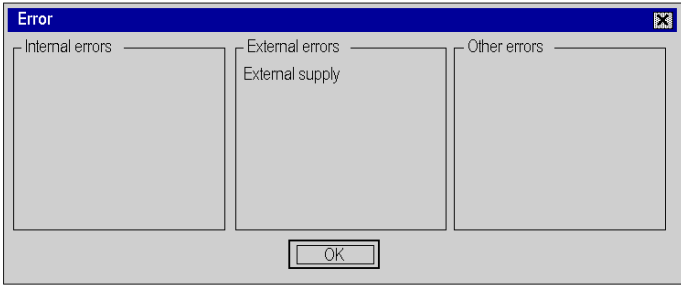
Step	Action
1	Access the module's debug screen.
2	<p>For the faulty channel, click on the button  situated in the Error column.</p> <p>Result: The list of channel faults appears.</p>  <p>Note: Channel diagnostics information can also be accessed by program (instruction READ_STS).</p>

Installation of the discrete reflex module

38

Subject of this Chapter

This chapter presents the specific installation features of discrete reflex module TSX DMY 28 RFK.

What's in this Chapter?

This chapter contains the following sections:

Section	Topic	Page
38.1	General presentation of discrete reflex module	464
38.2	Configuration of the reflex discrete module	467
38.3	Reflex function blocks	475
38.4	Modification of internal values using MOD_PARAM	521

38.1 General presentation of discrete reflex module

Subject of this section

This section presents the objectives of this module and the different functions available.

What's in this Section?

This section contains the following topics:

Topic	Page
General description of the reflex discrete module	465
Description of the reflex discrete module	466

General description of the reflex discrete module

General

The standard architecture of the PLC based on input/output modules and periodic or event tasks does not allow the reaction time necessary for certain types of applications.

The purpose of the **TSX DMY 28RFK** reflex discrete module is to resolve these specific cases of applications. For this reason, it has :

- a better response time than that of the Fast task or event task.
- an output reaction with a simple logic less than 0.5 ms,
- control over the speed of a moving part and stopping of movement when the speed falls too low,
- tracking between movements,
- timers with a time base of 0.1 ms,
- generation of continuous oscillation at a fixed frequency but with a variable mark-space ratio,
- ...

Description of the reflex discrete module

Operating principle

The **TSX DMY 28RFK** module works independently from the PLC task. It has its own inputs/outputs (16I/12O) and therefore guarantees a reaction time of less than 1 ms.

At the same time, but at the rate of the PLC task allocated to them, the variables within the module are exchanged with the PLC processor.

These variables are :

- the image bits of the state of the physical inputs of the module (%I),
- the image bits of the state of the physical and auxiliary outputs of the module (%O),
- the command bits of the module's outputs (%Q).

Operating principle

The following illustration summarizes the operating principle of the reflex discrete module.

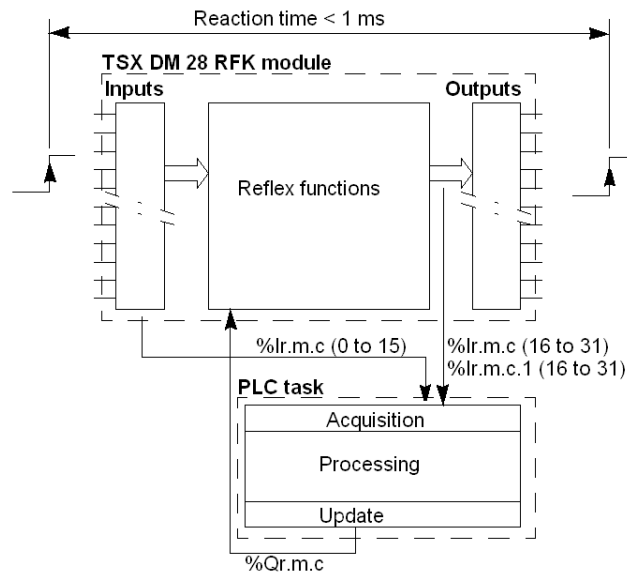

38.2 Configuration of the reflex discrete module

Aim of this sub-section

This sub-section shows the specific features associated with the configuration of a reflex discrete module.

What's in this Section?

This section contains the following topics:

Topic	Page
Configuration of the Reflex Discrete Module	468
Description of the reflex function configuration editor	469
How to assign and then configure a reflex function	471
How to set the configuration parameters of a reflex function	472
How to associate an event with a virtual output	473

Configuration of the Reflex Discrete Module

Introduction

The **TSX DMY 28RFK** reflex discrete module specifies the parameters of the standard discrete inputs/outputs (see page 412).

However, it has its own specific parameters, such as:

- the assignment, for a given output channel, of a reflex function (see page 471),
- the association of an event with a virtual output (see page 473).

A reflex function, thus assigned to a given channel, must in turn be configured and have its internal parameters adjusted (see page 472).

Illustration

The following screen shows a few examples of function assignments for a given channel.

16E 24VCC, 12S REFLEX

Channel 8
 Channel 16
 Channel 24

Function: LADDER Discrete outputs

Task: MAST

Supply monitoring

Reset: Programmed

Config Inputs | **Config Outputs** | Adjust Outputs

	Symbol	Desc. value	Functions	Event
16		Fallback 0	Direct	
17		Fallback 0	Combinational	
18		Fallback 0	OSCILLATOR	
19		Fallback 0	TIMER in operation	
20		Fallback 0	TIMER idle	
21		Fallback 0	COUNTER, 2 thresholds	
22		Fallback 0	PWM generation	
23		Fallback 0	Command/counting	
24		Fallback 0	Fault signaling	
25		Fallback 0	Direct	
26		Fallback 0	Direct	
27		Fallback 0	Direct	
28 v		Fallback 0	Direct	
29 v		Fallback 0	Direct	RE FE EVT 2
30 v		Fallback 0	Combinational	RE EVT 3
31 v		Fallback 0	Combinational	RE EVT 4

Description of the reflex function configuration editor

At a Glance

The reflex function configuration editor consists of a grid allowing you to choose the function block and to enter graphic objects relating to the sequential logic of the block.

Illustration

The following illustration shows the configuration zone of a reflex function block.

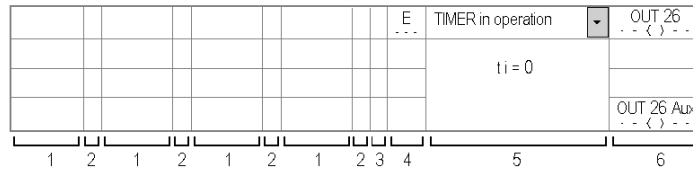

Description

The following table shows the various parts of the configuration zone.

Address	Function
1	Columns allowing contacts to be entered with their associated language object.
2	Columns allowing horizontal and vertical links to be entered between the contacts.
3	Column allowing the inputs of function blocks to be set to 1 or linked with the combinational block.
4	Column displaying the inputs relating to the function block selected.
5	Column: <ul style="list-style-type: none"> ● displaying the type of internal parameter used by the block, ● making it possible to select the chosen reflex function.
6	Column allowing the type of output coil to be entered.

Description of graphic objects

The following table shows the various graphic objects available depending on the welcome cell or column.

Object	Column(s)	Description
-- --	1, 2, 3	Empty field
-----	1, 2, 3	Horizontal link
..... 	2	Vertical link
1 -	3	Input set to 1
---- ----	1	Normally open contact
---- / ----	1	Normally closed contact
----()----	6	Direct coil
----(/)----	6	Negated coil

How to assign and then configure a reflex function

At a Glance

By default, the output channels of a reflex module are classified as standard discrete outputs. It is therefore necessary to reassign the chosen function for each channel used.

Configuring a reflex function involves defining its operating conditions such as :

- the sequential logic associated with the various inputs,
- the type of output chosen,
- the parameter-setting of the block.

The sequential logic is created with ladder language using the language objects associated with the reflex module concerned.

Procedure

The following table shows the various steps for configuring a reflex function block.

Step	Action
1	Access the module configuration screen.
2	Select the Config. outputs tab.
3	Click in the Functions cell of the channel to be assigned.
4	From the drop-down list, select the chosen function.
5	Carry out the sequential logic. To do this, click in the chosen cell, then : <ul style="list-style-type: none"> ● select a graphic object (contract, link, input set to 1), ● for a contact, select : <ul style="list-style-type: none"> ● the variable (%Ixy, %Qxy, ERR), ● the address i. ● select the coil type.
6	Confirm the configuration.

How to set the configuration parameters of a reflex function

Introduction

Some reflex function blocks have internal parameters (values between 0 and 65535), which they need for operation (e.g. : time thresholds).

These parameters can be modified :

- from the module adjustment screen (only in local mode),
- by the program (see page 425).

Instructions

The following table describes the procedure for modifying the adjustment parameters of a reflex function block.

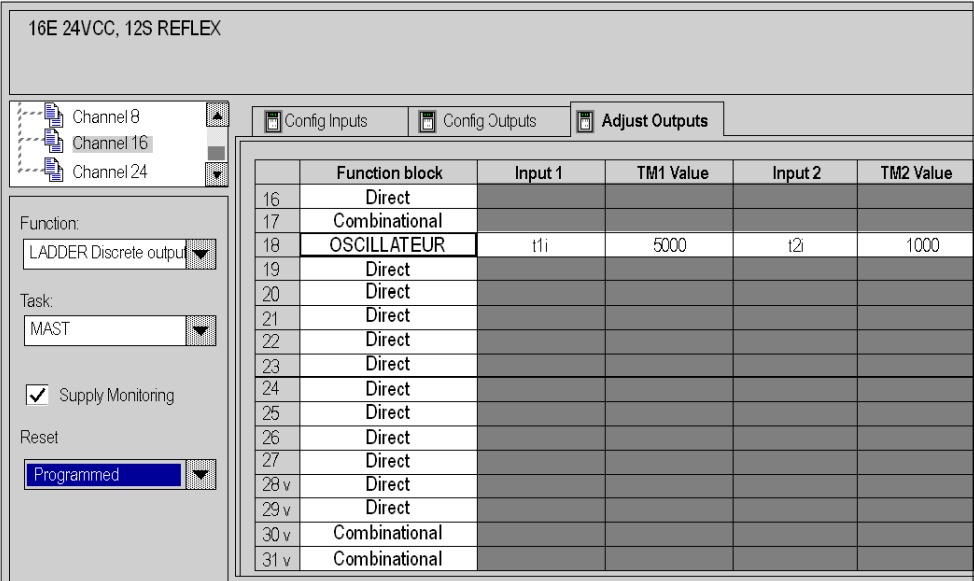
Step	Action
1	Access the module configuration screen.
2	<p>Select the Adjust outputs tab. Result: the following screen appears:</p> 
3	For the channel concerned, select the cell corresponding to the parameter to be entered.
4	Enter the parameter.
5	Confirm the modification with the Edit →Validate menu command.

How to associate an event with a virtual output

Introduction

Virtual outputs are not the module's physical outputs but they act on the internal status bits of the module and can be associated with events.

A virtual output can therefore trigger an event task of the PLC processor.

Properties of event outputs

The possible properties of event processing are:

- Normal (no event associated with the channel),
- channel by channel event processing:
 - Event triggered on a rising edge (RE),
 - Event triggered on falling edge (FE),
 - Event triggered on rising and falling edges.

If both transition types are selected on one channel, only one event number is assigned to the channel.

Event inputs are assigned an **(Evti)** processing number. These numbers range from:

- **0** to **31** for TSX 571** processors,
- **0** to **63** for TSX 572**,TSX 573**,TSX 574**, TSX PCI 572**,TSX PCI 574** and TSX 575** processors.

The highest priority event processing (Evti) is number 0. This can only be assigned to channel 0.

NOTE: The default event number is the first available in the list.

A number entered manually outside the tolerance range is not accepted when validating.

Adding, deleting, or changing the event number is not accessible in online mode.

Performance

The maximum frequency of events is 1 kHz / Number of event-programmed outputs.

The maximum number of events in burst is 100 events per 100 ms.

Procedure

The following table shows the various steps involved in associating an event with an output and then defining its properties.

Step	Action
1	Access the module configuration screen.
2	Select the Config. outputs tab.
3	Double-click in the Event cell of the channel to be assigned.
4	Select the desired function.
5	Enter the event number Evt.
6	Repeat the operation for each channel to be configured (from step3).

38.3 Reflex function blocks

Subject of this Section

This section presents the different reflex functions available.

What's in this Section?

This section contains the following topics:

Topic	Page
Function block : Direct	476
Reflex function block : Combinational	477
Reflex function block: Operation timer	479
Reflex function block: Idle timer	480
Reflex function block: Operation-idle timer	481
Reflex function block: 2 value operation timer	483
Reflex function block: Operation-idle time with value selection	486
Reflex function block: Retriggerable monostable	489
Reflex function block: Monostable with time delay	490
Reflex function block: 2 value monostable	492
Reflex function block: Oscillator	494
Reflex function block: D flip-flop	495
Reflex function block: T flip-flop	497
Reflex Function Block: 2 Threshold Counter	499
Reflex function block: Single electronic CAM	501
Reflex function block: 1 threshold intervalometer	503
Reflex function block: Burst	505
Reflex function block: PWM (Pulse Width Modulation)	506
Reflex function block: Detection of underspeed	508
Reflex function block: Speed monitoring	510
Reflex function block: Type 1 command-check	513
Reflex function block: Type 2 command-check	515
Reflex function block: Command-counting	517
Reflex function block: Fault Signaling	519

Function block : Direct

Role

This default block applies no reflex function to the module's output. The output is therefore controlled from the application as on a module of standard discrete outputs.

Structure

The table below shows the various interfaces of the block.

Name	Meaning
x	Physical output of the block.
x Aux	Auxiliary output within the block.

Operation

The physical output x is directly controlled by its command bit `CMD_OUT (%Qr.m.c)` updated by the PLC processor.

The values of the **x** and **x Aux** outputs are the same.

Illustration

The illustration below summarizes the **Direct** function.

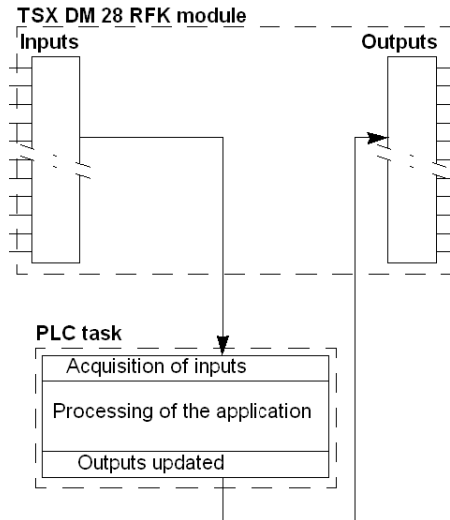

Reflex function block : Combinational

Role

This functions is used to create a logical function between the inputs and one or more outputs of the module.

Structure

The table below shows the various interfaces of the block.

Name	Meaning
x	Physical output of the block.
x Aux	Auxiliary output within the block.

Operation

The logic function entered is directly applied to the output **x**.

The values of the **x** and **x Aux** outputs are the same.

NOTE: a logical function can consist of several combinational functions by using the **PHYS_OUT** (%l.r.m.c.0) and **AUX_OUT** (%l.r.m.c.1) bits associated with the channels of the outputs as intervening variables.

Illustration 1

The illustration below shows an example of a simple combinational function

%I2.1.0 - - () - -	%I2.0.0 - - () - -	%I2.4.0 - - () - -						Combinational	OUT 16 - - () - -
	%I2.16.0 - - () - -								
									OUT 16 Aux - - () - -

Illustration 2

The illustration below shows an example of a combinational function using the auxiliary output of the first combinational as an intervening variable.

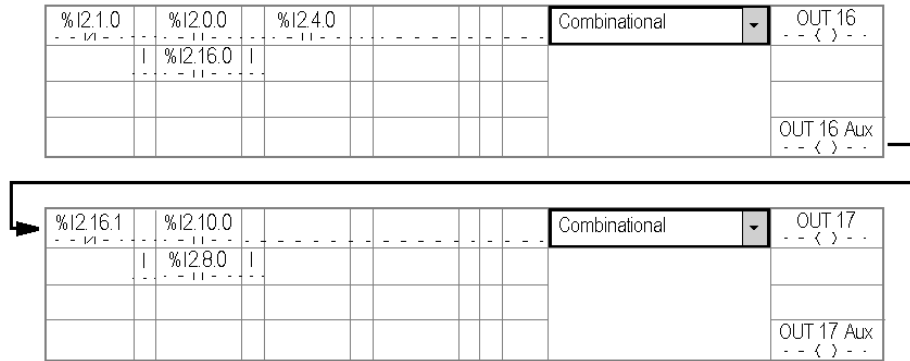

Reflex function block: Operation timer

Role

This function is used to apply an on-delay to an action.

Structure

The table below shows the block's different interfaces.

Name	Meaning	Illustration
E	Timer input.	
x	Timer's physical output.	
x Aux	Block's internal auxiliary output.	

Operation

This table describes the different operating phases of the operation timer.

Phase	Description
1	On the rising edge of the E input, time-out ti is launched (time base of 0.1 ms).
2	When the time-out is over, the x output changes to 1. If the high status of input E lasts less time than ti , output x stays at 0.
Note: The values of outputs x and x Aux are identical.	

Illustration

The illustration below shows the trend diagram of the operation timer function block.

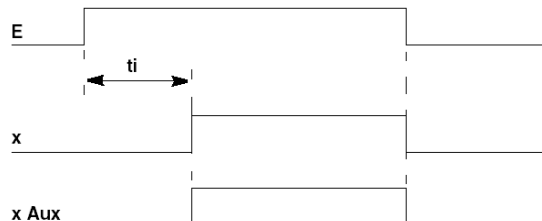

Reflex function block: Idle timer

Role

This function is used to apply an off-delay to an action.

Structure

The table below shows the block's different interfaces.

Name	Meaning	Illustration
E	Timer input.	
x	Timer's physical output.	
x Aux	Block's internal auxiliary output.	

Operation

This table describes the different operating phases of the idle timer.

Phase	Description
1	The x output changes to 1 when the E input changes to 1.
2	On the falling edge of the E input, time-out ti is launched (time base of 0.1ms).
3	When the time-out is over, the x output changes to 0. If the low status of input E lasts less time than ti , output x stays at 1.

Note: The values of outputs **x** and **x Aux** are identical.

Illustration

The illustration below shows the trend diagram of the idle timer function block.

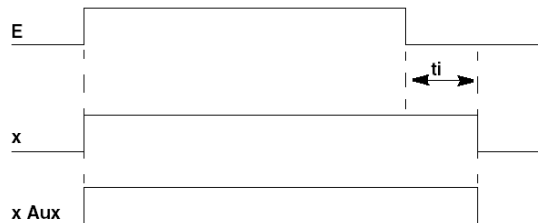

Reflex function block: Operation-idle timer

Role

This function is used to apply an on-off-delay to an action.

Structure

The table below shows the block's different interfaces.

Name	Meaning	Illustration
E	Timer input.	
x	Timer's physical output.	
x Aux	Block's internal auxiliary output.	

Operation

This table describes the different operating phases of the operation-idle timer.

Phase	Description
1	On the rising edge of the E input (on-delay) , time-out tri is launched (time base of 0.1ms).
2	When time-out tri is over, the x output changes to 1. If the high status of input E lasts less time than tri , output x stays at 0.
3	On the falling edge of the E input (off-delay) , time-out tfi is launched (time base of 0.1ms).
4	When time-out tfi is over, the x output changes to 0. During time-out tfi , if the low status of input E lasts less time than tfi , output x stays at 1.
Note: The x Aux output is at 1 as long as input E or output x is at 1.	

Illustration

The illustration below shows the trend diagram of the operation-idle timer function block.

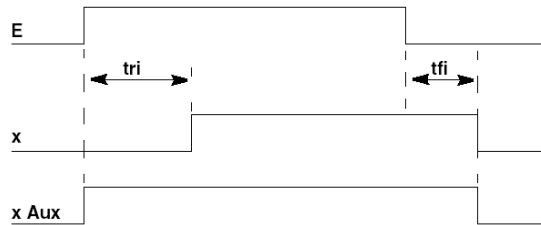

Reflex function block: 2 value operation timer

Role

This function is used to apply a **t1i** or **t2i** on-delay to an action.

Structure

The table below shows the block's different interfaces.

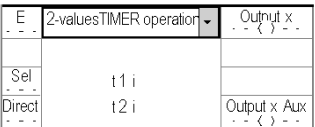
Name	Meaning
E	Timer input.
Sel	Selection of time-out t1i or t2i . <ul style="list-style-type: none"> Sel = 0: time-out t1i, Sel = 1: time-out t2i,
Direct	Selection of block (for string operation). <ul style="list-style-type: none"> Direct = 0: block selected Direct = 1: block not selected (output x takes the value of E).
x	Timer's physical output.
x Aux	Block's internal auxiliary output.
Illustration	
	

Operation

This table describes the different operating phases of the 2 value operation timer.

Phase	Description
1	On the rising edge of the E input, a time-out corresponding to the status of input Sel is launched.
2	When the time-out is over, the x and x Aux outputs change to 1. If the high status of input E lasts less time than the selected time-out, output x stays at 0.

Illustration

The illustration below shows the trend diagram of the 2 value operation timer function block.

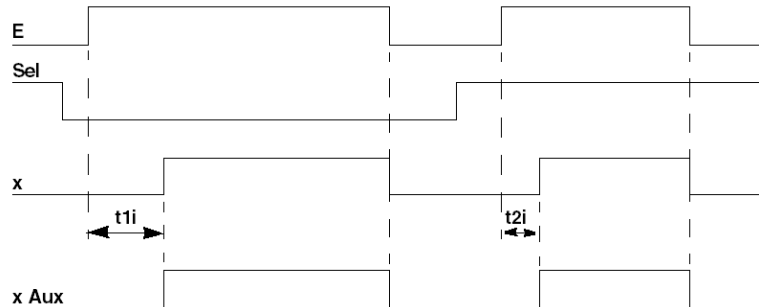

String operation

It is possible to increase the number of time-outs which can be selected by stringing together several blocks, with the **x** output of one forming the **E** input of the next.

Phase	Description
1	On the rising edge of the E input of the first block a time-out is launched, corresponding to: <ul style="list-style-type: none"> ● the block whose Direct input is at 0, ● the status of the Sel input. <p>Note: Two blocks must not simultaneously have their Direct inputs set to 0.</p>
2	When the time-out is over, the x and x Aux outputs change to 1. If the high status of the E input of the first block lasts less time than the selected time-out, output x stays at 0.
3	The x output changes to 0 on the falling edge of the E input .
<p>Note:</p> <ul style="list-style-type: none"> ● x and x Aux have identical values. ● the x Aux outputs can be used for tracking, ● when stringing together several blocks, it is essential to change the statuses of Sel and Direct only when the 0 status of input E is at 0. 	

Illustration

The table below shows the tracking of two timers.

E	2-values TIMER operation	Output x	E	2-values TIMER operation	Output x1
.		{ }	.		{ }
Sel	t1 i		Sel	t1 i	
Direct	t2 i	Output x Aux	Direct	t2 i	Output x Aux1

Reflex function block: Operation-idle time with value selection

Role

This function is used to apply a **t1i** or **t2i** on-delay or off-delay to an action.

The assignment of a **t1i** time-out on-delay to an action causes the **t2i** off-delay for this same action.

Similarly, the assignment of a **t2i** time-out on-delay causes a **t1i** off-delay to be assigned.

Structure

The table below shows the block's different interfaces.

Name	Meaning
E	Timer input.
Sel	Selection of time-out t1i or t2i . <ul style="list-style-type: none"> ● Sel = 0 : t1i on-delay, t2i off-delay. ● Sel = 1 : t2i on-delay, t1i off-delay.
Direct	Selection of block (for string operation). <ul style="list-style-type: none"> ● Direct = 0: block selected ● Direct = 1: block not selected (output x takes the value of E).
x	Timer's physical output.
x Aux	Block's internal auxiliary output.
Illustration	

Operation

This table describes the different operating phases of the operation-idle timer with value selection.

Phase	Description
1	On the rising edge of input E : <ul style="list-style-type: none"> ● the time-out corresponding to the status of input Sel is launched, ● output x Aux changes to 1.
2	When the selected time-out is over <ul style="list-style-type: none"> ● output x changes to 1, ● output x Aux changes to 0. If the high status of input E lasts less time than the selected time-out, output x stays at 0.
3	On the falling edge of input E : <ul style="list-style-type: none"> ● the time-out corresponding to the status of input Sel is launched, ● output x Aux changes to 1.
4	When the selected time-out is over <ul style="list-style-type: none"> ● output x changes to 1, ● output x Aux changes to 0. If the low status of input E lasts less time than the selected time-out, output x stays at 0.

Illustration

The illustration below shows the trend diagram of the operation-idle timer with value selection function block.

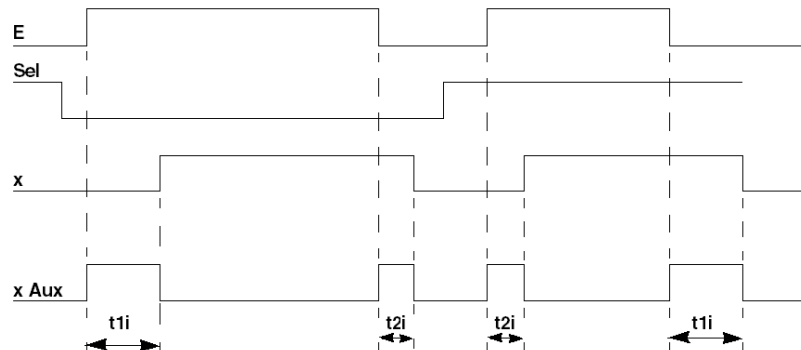

String operation

It is possible to increase the number of time-outs which can be selected by stringing together several blocks, with the **x** output of one forming the **E** input of the next.

Phase	Description
1	<p>On the rising edge of input E of the first block:</p> <ul style="list-style-type: none"> the time-out is launched, corresponding to: <ul style="list-style-type: none"> the block whose Direct input is at 0, the status of the Sel input. output x Aux changes to 1. <p>Note: Two blocks must not simultaneously have their Direct inputs set to 0.</p>
2	<p>When the selected time-out is over</p> <ul style="list-style-type: none"> output x of the relevant block changes to 1. output x Aux of the relevant block changes to 0. <p>If the high status of the E input of the first block lasts less time than the selected time-out, output x stays at 0.</p>
3	<p>On the falling edge of input E of the first block:</p> <ul style="list-style-type: none"> the time-out is launched, corresponding to: <ul style="list-style-type: none"> the block whose Direct input is at 0, the status of the Sel input. output x Aux changes to 1. <p>Note: Two blocks must not simultaneously have their Direct inputs set to 0.</p>
4	<p>When the selected time-out is over:</p> <ul style="list-style-type: none"> output x of the relevant block changes to 1. output x Aux of the relevant block changes to 0. <p>If the low status of the E input of the first block lasts less time than the selected time-out, output x stays at 0.</p>
5	The x output changes to 0 on the falling edge of the E input.
<p>Note:When stringing together several blocks It is essential to change the statuses of the Sel and Direct inputs only when the status of input E of the first block is set to 0..</p>	

Illustration

The table below shows the tracking of the two timers.



Reflex function block: Retriggerable monostable

Role

This function launches an action of duration t_i , with the possibility of extending it for an identical duration.

Structure

The table below shows the block's different interfaces.

Name	Meaning	Illustration
E	Monostable input.	
x	Monostable's physical output.	
x Aux	Block's internal auxiliary output.	

Operation

This table describes the different operating phases of the retriggerable monostable.

Phase	Description
1	On the rising edge of input E (on-delay): <ul style="list-style-type: none"> time-out t_i is launched (time-base of 0.1ms), outputs x and x Aux change to 1.
2	When time-out t_i is over, outputs x and x Aux change to 0. If a new rising edge for input E occurs before time-out t_i has elapsed, outputs x and x Aux remain at 1 for a further time-out t_i .

Illustration

The illustration below shows the trend diagram of the retriggerable monostable function block.

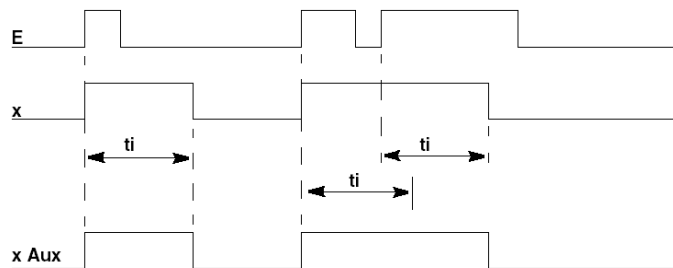

Reflex function block: Monostable with time delay

Role

This function enables an action of a duration **t2i** to be launched with a **t1i** delay, with the possibility of extending it for an identical duration.

Structure

The table below shows the block's different interfaces.

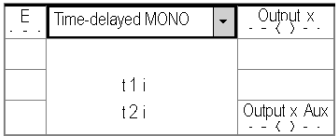
Name	Meaning	Illustration
E	Monostable input.	
x	Monostable's physical output.	
x Aux	Block's internal auxiliary output.	

Operation

This table describes the different operating phases of the monostable with time delay.

Phase	Description
1	On the rising edge of input E : <ul style="list-style-type: none"> ● time-out t1i is launched (time-base of 0.1ms), ● output x Aux changes to 1.
2	When time out t1i is over: <ul style="list-style-type: none"> ● time-out t2i is launched (time base of 0.1ms), ● output x changes to 1 for duration t2i. If the high status of input E lasts less time than time-out t1i , output x stays at 0.
3	When time-out t2i is over, outputs x and x Aux change to 0. If a new rising edge for input E occurs before time-out t2i has elapsed: <ul style="list-style-type: none"> ● output x remains at 1 for duration t2i of the cycle in progress. ● a new cycle begins (see phase).

Illustration

The illustration below shows the trend diagram of the monostable with time delay function block.

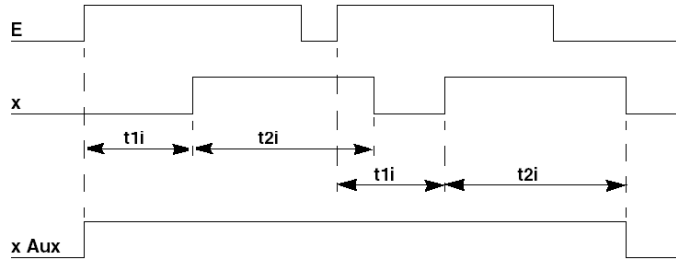

Reflex function block: 2 value monostable

Role

This function enables an action of duration **t1i** or **t2i** to be applied to the triggering of an action.

Structure

The table below shows the block's different interfaces.

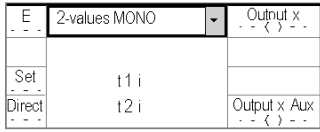
Name	Meaning
E	Monostable input.
Sel	Selection of time-out t1i or t2i . <ul style="list-style-type: none"> Sel = 0: t1i on-delay, Sel = 1: t2i on-delay,
Direct	Selection of block (for string operation). <ul style="list-style-type: none"> Direct = 0: block selected Direct = 1: block not selected (output x takes the value of E).
x	Monostable's physical output.
x Aux	Block's internal auxiliary output.
Illustration	
	

Operation

This table describes the different operating phases of the 2 value monostable.

Phase	Description
1	On the rising edge of input E : <ul style="list-style-type: none"> a time-out corresponding to the status of input Sel is launched (time base of 0.1ms), outputs x and x Aux change to 1.
2	When the time-out is over, the x and x Aux outputs change to 0.

Illustration

The illustration below shows the trend diagram of the monostable with time delay function block.

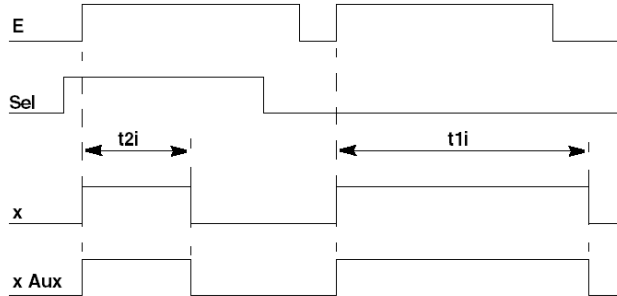

String operation

It is possible to increase the number of time-outs which can be selected by stringing together several blocks, with the **x** output of one forming the **E** input of the next.

Phase	Description
1	<p>On the rising edge of input E of the first block:</p> <ul style="list-style-type: none"> the time-out is launched, corresponding to: <ul style="list-style-type: none"> the block whose Direct input is at 0, the status of the Sel input. outputs x and x Aux change to 1. <p>Note: Two blocks must not simultaneously have their Direct inputs set to 0.</p>
2	When the time-out is over, the x and x Aux outputs change to 0.

Note: When stringing together several blocks it is essential to change the statuses of the **Sel** and **Direct** inputs only when the status of input **E** is set to 0.

Illustration

The table below shows the tracking of the two monostables.

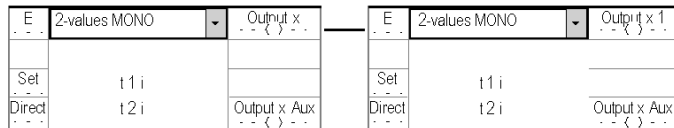

Reflex function block: Oscillator

Role

This function enables a time base to be created, with the option of defining the signal parameters (status 0 or 1).

Structure

The table below shows the block's different interfaces.

Name	Meaning	Illustration
E	Oscillator input.	
x	Oscillator's physical output.	
x Aux	Block's internal auxiliary output.	

Operation

This table describes the different operating phases of the oscillator.

Phase	Description
1	On the rising edge of input E : <ul style="list-style-type: none"> output x oscillates for period t1i + t2i where: <ul style="list-style-type: none"> t1i = length of high status of oscillation (time base of 0.1ms), t2i = length of low status of oscillation (time base of 0.1ms), output x Aux changes to 1.
2	On the falling edge of input E : <ul style="list-style-type: none"> output x changes to 0 as soon as t1i for the current period is over, the x output changes to 0 when the current period is over.

Illustration

The illustration below shows the trend diagram of the oscillator function block.

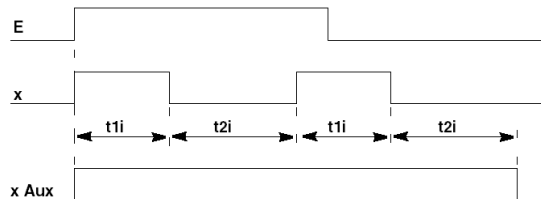

Reflex function block: D flip-flop

Role

This function is used to carry out sequential logic functions, such as memorization of an edge, etc.

Structure

The table below shows the block's different interfaces.

Name	Meaning
D	Flip-flop input.
CLK	Enable input.
SET	Output x set to 1.
RESET	Output x set to 0. This input takes priority over SET input.
x	Flip-flop's physical output.
x Aux	Block's internal auxiliary output.

Illustration

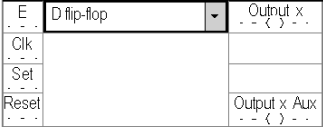

The illustration shows a software interface for a D flip-flop block. The block is labeled "D flip-flop" and has several input and output ports: "E", "Clk", "Set", "Reset", "Output x", and "Output x Aux". The "Output x" and "Output x Aux" ports are shown with a small icon of a flip-flop symbol.

Operation

This table describes the different operating phases of the D flip-flop.

Phase	Description
1	<p>On the rising edge of input CLK:</p> <ul style="list-style-type: none"> output x takes the status of input D, output x Aux takes the opposite status to input D.

Illustration

The illustration below shows the trend diagram of the D flip-flop function block.

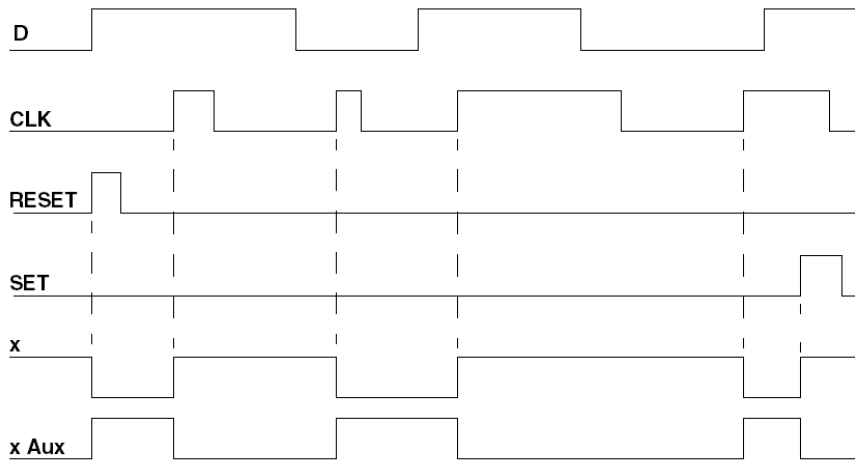

Reflex function block: T flip-flop

Role

This function allows a 2-way split to be performed.

Structure

The table below shows the block's different interfaces.

Name	Meaning
E	Flip-flop input.
CLK	Enable input.
SET	Outputs x / x Aux set respectively to 1 / 0.
RESET	Outputs x / x Aux set respectively to 0 / 1. This input takes priority over SET input.
x	Flip-flop's physical output.
x Aux	Block's internal auxiliary output.

Illustration

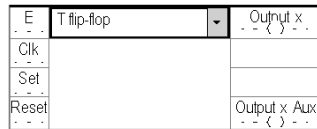

Operation

This table describes the different operating phases of the T flip-flop.

Phase	Description
1	<p>On the rising edge of input CLK:</p> <ul style="list-style-type: none"> ● if input E is at 1: <ul style="list-style-type: none"> ● output x takes the opposite status to its current status, ● output x Aux takes the opposite value to x, ● if input E is at 0, outputs x and x Aux remain at that status.

Illustration

The illustration below shows the trend diagram of the T flip-flop function block.

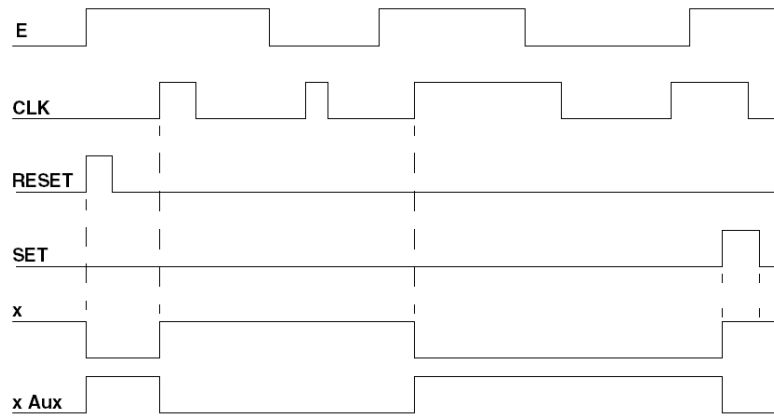

Reflex Function Block: 2 Threshold Counter

Role

This counting function is used to detect when a **th1** or **th2** threshold is crossed.

Structure

The following table shows the different interfaces of the block.

Name	Meaning
E	Enable input. <ul style="list-style-type: none"> ● E = 0: Input Up frozen, ● E = 1: Input Up enabled.
Up	Counter input. Note: Maximum performance of the counter is 500 Hz with a 50% duty cycle (with the Up input directly controlled by the physical input (without filtering)).
RESET	Counter initialization input. A Reset is required to acknowledge a change in the value of the threshold to be reached.
Sel	Selection of the counting threshold: <ul style="list-style-type: none"> ● Sel = 0: Threshold th1 selected, ● Sel = 1: Threshold th2 selected. Note: The maximum value of a threshold corresponds to the maximum number of pulses (65536 pulses).
x	Counter physical output.
x Aux	Block internal auxiliary output.

Illustration

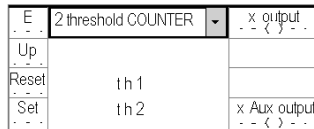

Operation

This table describes the different operating phases of the 2 threshold counter:

Phase	Description
1	On the rising edge of the RESET input: <ul style="list-style-type: none"> ● counter initialization to 0, ● the x and x Aux inputs switch to 0, ● counter on the rising edge of the Up input is incremented.
2	On the rising edge of the Up input, the counter is incremented (value not accessible).
3	When the selected threshold is reached, the x and x Aux inputs switch to 1.

Illustration

The illustration below shows the timing chart for the 2 threshold Counter function block.

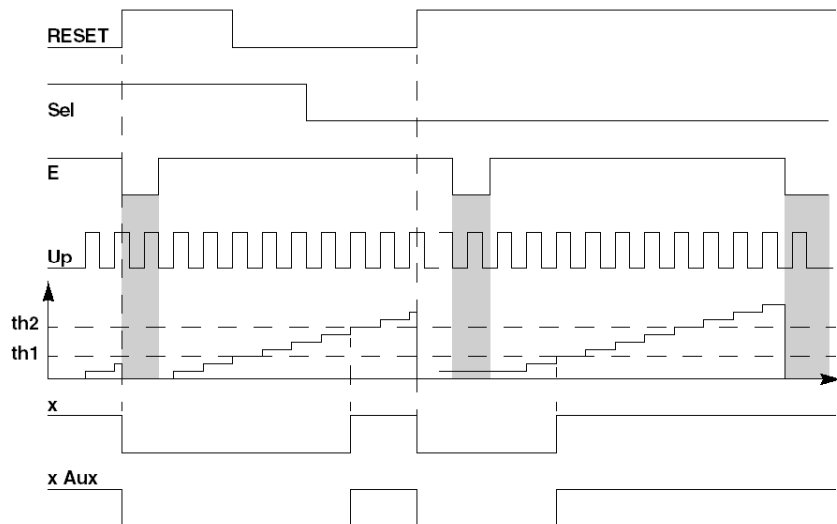

Reflex function block: Single electronic CAM

Role

This function is used to detect when the two thresholds **th1** and **th2** have been crossed.

Structure

The table below shows the block's different interfaces.

Name	Meaning
E	Enable input. <ul style="list-style-type: none"> ● E = 0: Up input frozen, ● E = 1: Up input valid.
Up	Counting input. Note: the maximum performance of the counter is 2 KHz (with the Up input directly controlled by the physical input (without filtering)).
RESET 0	Output x forced to 0.
RESET 1	Counter initialization input. Note: If the counter is not reset to 0, when it reaches the maximum value (65536 points), it will change to 0,1,2 etc. Therefore it is advisable to inhibit counting (E=0) by using the x Aux output in series with output E .
x	Cam's physical output.
x Aux	Block's internal auxiliary output.

Illustration

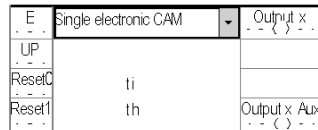

Operation

This table describes the different operating phases of the simple cam.

Phase	Description
1	On the rising edge of input RESET 1 : <ul style="list-style-type: none"> ● counter initialized to 0 ● input x Aux changes to 1, On the high status of input RESET 0 : <ul style="list-style-type: none"> ● input x is forced to 0.
2	On the rising edge of input Up , the counter is increased.
3	When threshold th1 is reached, output x changes to 1.
4	When threshold th2 is reached, outputs x and x Aux change to 0.

Illustration

The illustration below shows the trend diagram of the simple cam function block.

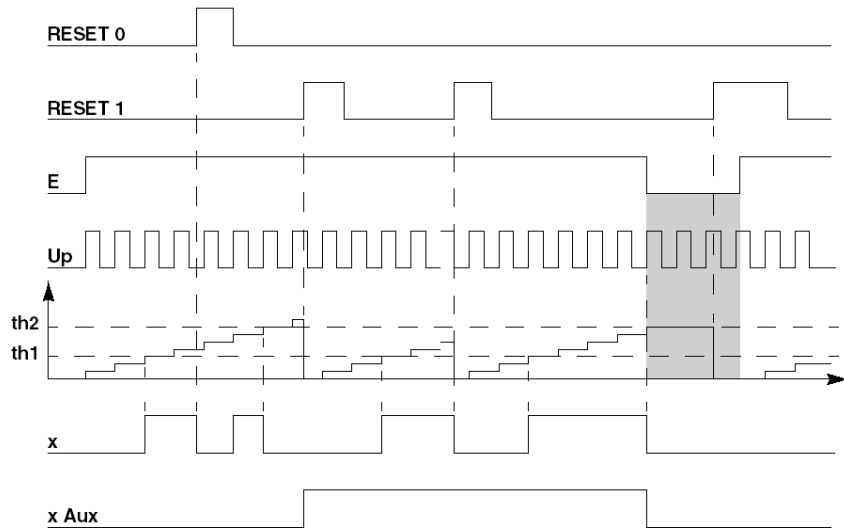

Reflex function block: 1 threshold intervalometer

Role

This function is used to trigger an action after an interval **th** with a maximum precision of 0.1ms

Structure

The table below shows the block's different interfaces.

Name	Meaning
E	Intervalometer initialization input.
RESET 1	Outputs x and x Aux are set to 0.
ti	Time-base (0.1ms to 6.5535 s).
x	Intervalometer's physical output.
x Aux	Block's internal auxiliary output.

Illustration

E	INTERVALOMETER_1	Output x
	ti	
Reset	th	Output x Aux

Operation

This table describes the different operating phases of the intervalometer.

Phase	Description
1	On the rising edge of input E : <ul style="list-style-type: none"> ● counter initialized to 0 ● input x changes to 0.
2	Counter increases at the rate of time-base ti .
3	When threshold th is reached, output x changes to 1.
4	On the falling edge of input E with output x at 1, output x Aux changes to 1.

Illustration

The illustration below shows the trend diagram of the intervalometer function block.

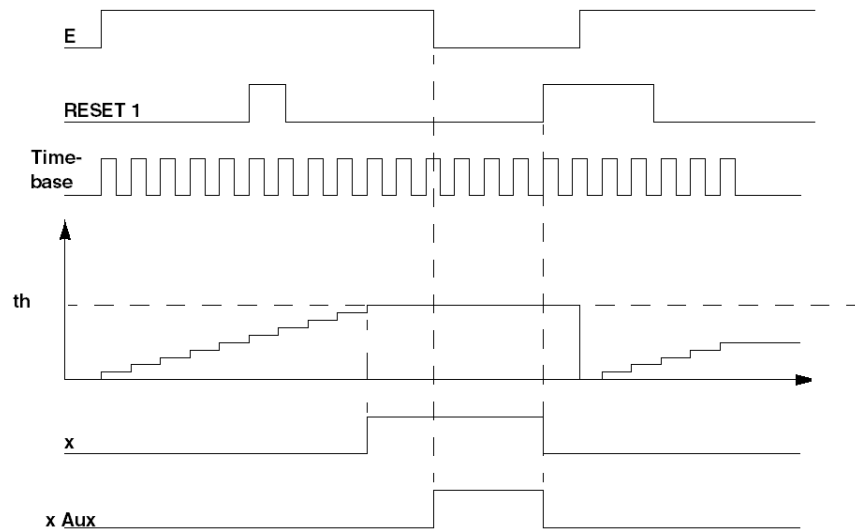

Reflex function block: Burst

Role

This function is used to generate a pulse stream of a time length $2 \times t_i$.

Structure

The table below shows the block's different interfaces.

Name	Meaning	Illustration
E	Block's input.	
x	Block's physical output.	
x Aux	Block's internal auxiliary output.	

Operation

This table describes the different operating phases of the Burst function block.

Phase	Description
1	On the rising edge of input E : <ul style="list-style-type: none"> ● oscillation of output x for n_i periods of time, ● input x Aux changes to 1,
2	When number of periods n_i is reached, output x Aux changes to 0. If output E changes to 0 before time periods n_i have elapsed: <ul style="list-style-type: none"> ● the oscillation stops at the low status of output x, ● input x Aux changes to 0,

Illustration

The illustration below shows the trend diagram of the burst function block.

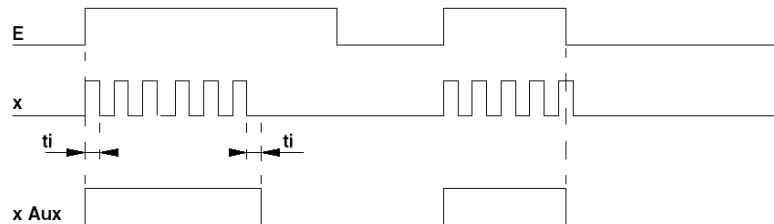

Reflex function block: PWM (Pulse Width Modulation)

Role

This function is used to generate a fixed period periodic signal **t1i** with a variable duty cycle **t2i/t1i**.

Structure

The table below shows the block's different interfaces.

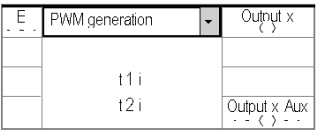
Name	Meaning	Illustration
E	Block's input.	
x	Block's physical output.	
x Aux	Block's internal auxiliary output (control output).	

Operation

This table describes the different operating phases of the PWM function block.

Phase	Description
1	On the rising edge of input E : <ul style="list-style-type: none"> ● oscillation of output x, ● control input x Aux changes to 1.
2	On the low status of input E : <ul style="list-style-type: none"> ● the oscillation of output x stops at its low status, ● control input x Aux changes to 0. <p>Note: if t2i (high status of period t1i) is higher than or equal to t1i, output x continually keeps the high status.</p>

Illustration

The illustration below shows the trend diagram of the PMW function block.

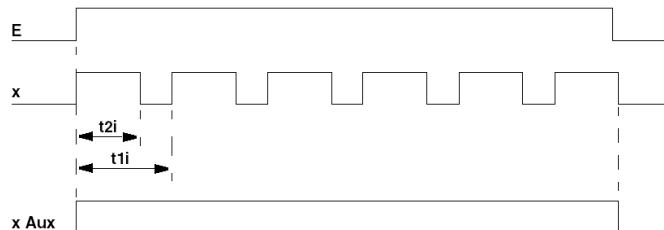

Characteristics

This table describes the characteristics of the PWM function block.

Characteristic	Value
Time Base	0.1 ms
F max	2 KHz
t1i (period)	0.1*(5 to 65535)
t2i (time on)	0.1*(2 to 65534)

Frequency and Duty Cycle

This table describes the frequency and the duty cycle range.

t1	Frequency	Step	Number of steps	Duty Cycle min	Duty Cycle max
5	2 KHz	20%	4	20%	80%
10	1 KHz	10%	9	10%	90%
100	100 Hz	1%	99	1%	99%
1000	10 Hz	0.1%	999	0.1%	99.9%
10000	1 Hz	0.01%	9999	0.01%	99.99%
65535	0.15 Hz	0.0015%	65534	0.0015%	99.9985%

Reflex function block: Detection of underspeed

Role

This function is used to halt an action, after a start phase **t1i** (masking), if the time elapsing between two consecutive pulses is higher than **t2i**.

Structure

The table below shows the block's different interfaces.

Name	Meaning	Illustration
E	Enable function input.	
FB	Control input.	
x	Block's physical output.	
x Aux	Block's internal auxiliary output.	

Operation

This table describes the different operating phases of the speed detection.

Phase	Description
1	On the rising edge of input E : <ul style="list-style-type: none"> time-out t1i (masking time) is launched, input x changes to 1.
2	When time-out t1 has elapsed, and then on each edge of input à FB , time-out t2i is launched. If the rising edges of input FB are spaced out at interval t2i : <ul style="list-style-type: none"> output x changes to 0, output x Aux changes to 1 (signaling end of movement). If input E changes to 0, outputs x and x Aux change to 0.

Illustration

The illustration below shows the trend diagram of the speed detection function block.

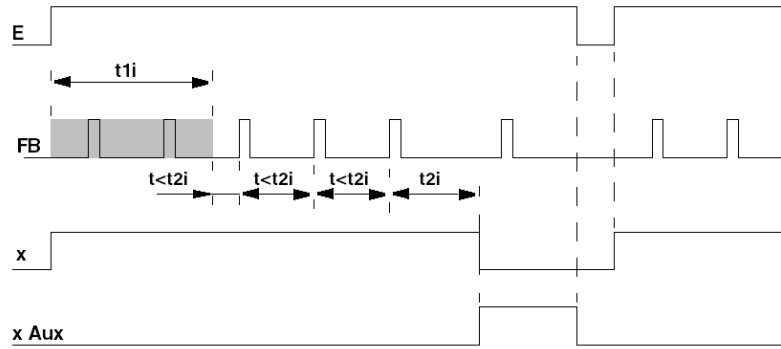

Reflex function block: Speed monitoring

Role

This function is used to control or halt an action according to two thresholds **t1i** and **t2i**.

Structure

The table below shows the block's different interfaces.

Name	Meaning	Illustration
E	Enable function input.	
FB	Control input.	
x	Block's physical output.	
x Aux	Speed control output.	

Application example

Activation of a conveyor belt upstream (controlled by the **x Aux** input) depending on the speed of a conveyor belt downstream:

- conveyor belt operational when the speed of the downstream belt is greater than the high threshold **1/t1i**,
- conveyor belt stops when the speed of the downstream belt is less than the low threshold **1/t2i**,

This involves analyzing the time elapsed between 2 consecutive pulses on control input **FB**.

The following graph illustrates the application example given above.

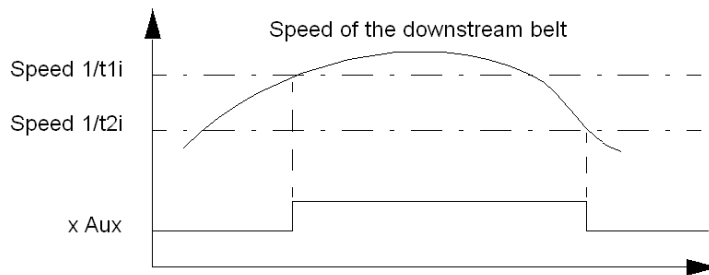

Operation

This table describes the different operating phases of the speed monitoring function.

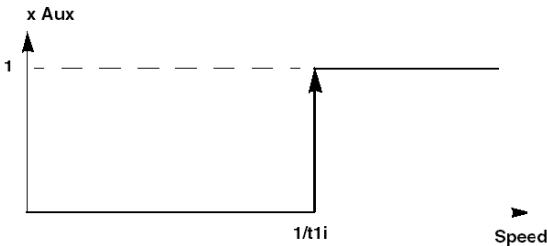
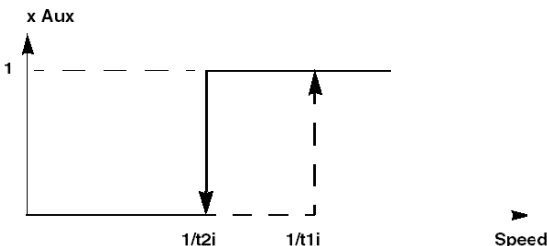
Phase	Description
1	On the rising edge of input E : <ul style="list-style-type: none"> ● time-out t1i is launched, ● input x changes to 1.
2	As long as the interval between 2 rising edges of input FB remains greater than t1i : <ul style="list-style-type: none"> ● time-out t1i is relaunched on the rising edge of input FB. If the interval between 2 rising edges of input FB falls below t1i : <ul style="list-style-type: none"> ● output x Aux changes to 1, ● time-out t2i is launched, If input E changes to 0, outputs x and x Aux change to 0. <div style="text-align: center;">  </div>
3	As long as the interval between 2 rising edges of input FB is less than t2i : <ul style="list-style-type: none"> ● time-out t2i is relaunched on the rising edge of input FB. If the interval between 2 rising edges of input FB becomes greater than t2i : <ul style="list-style-type: none"> ● output x Aux changes to 0, ● time-out t1i is launched (see phase), If input E changes to 0, outputs x and x Aux change to 0. <div style="text-align: center;">  </div>
<p>Note: The operation defined above implies that t2i > t1i.</p>	

Illustration

The illustration below shows the trend diagram of the speed monitoring function block.

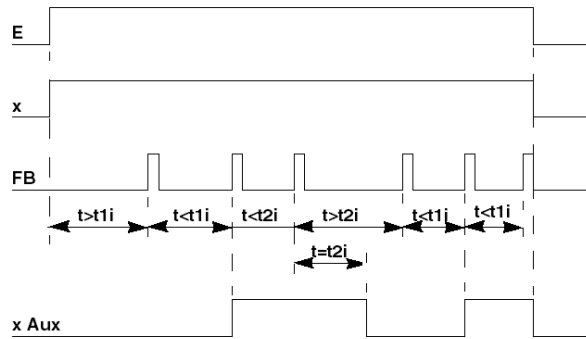

Reflex function block: Type 1 command-check

Role

This function is used to command an action and to check whether it has been carried out after time period **ti**

Structure

The table below shows the block's different interfaces.

Name	Meaning	Illustration
Cde	Command input.	
Ctrl	Control input.	
Acq	Acknowledgement of fault.	
x	Block's physical output.	
x Aux	Block's internal auxiliary output.	

Operation

This table describes the different operating phases of the type 1 command-check function.

Phase	Description
1	On the rising edge of input Cde : <ul style="list-style-type: none"> time-out ti is launched, input x changes to 1.
2	When time-out ti is over: <ul style="list-style-type: none"> if the Ctrl signal changes to status 1 during the time-out interval, the x Aux output stays at 0 (normal situation), if the Ctrl signal is not received, the x Aux output changes to 1 (type A error signal). if the Ctrl signal falls back while the Cde input is at 1, the x Aux output changes to 1 (type B error signal). <p>A rising edge on the Acq input with the Ctrl input at 1 causes the x Aux to be set to 0.</p>
3	On the falling edge of the Cde input, the x and x Aux outputs change to 0.

Illustration

The illustration below shows the trend diagram of the type 1 command-check function block.

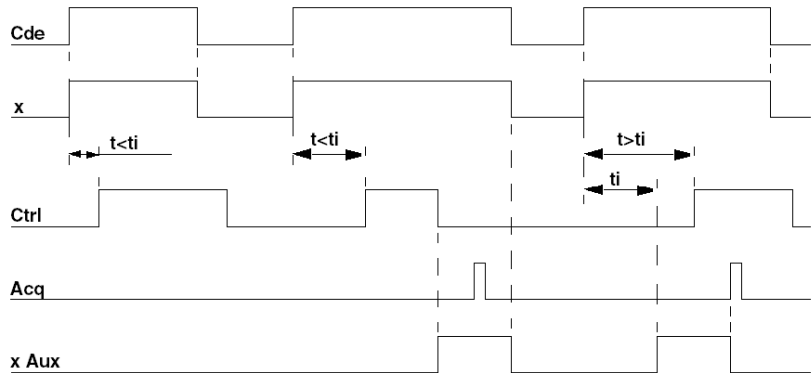

Reflex function block: Type 2 command-check

Role

This function is used to:

- command an action and check whether it has been carried out after time period **t1i**,
- delete the action and check whether it has been deleted after time period **t2i**.

Structure

The table below shows the block's different interfaces.

Name	Meaning	Illustration
Cde	Command input.	
Ctrl n	Control n input	
Acq	Acknowledgement of fault.	
x	Block's physical output.	
x Aux	Block's internal auxiliary output.	

Operation

This table describes the different operating phases of the type 2 command-check function.

Phase	Description
1	On the rising edge of input Cde : <ul style="list-style-type: none"> • time-out t1i is launched, • input x changes to 1.
2	When time out t1i is over: <ul style="list-style-type: none"> • if the Ctrl1 signal changes to status 1 during time-out interval t1i, the x Aux input stays at 0 (normal situation), • if the Ctrl1 signal is not received, the x Aux output changes to 1 (type A error signal). • if the Ctrl1 signal falls back while the Cde input is at 1, the x Aux output changes to 1 (type B error signal). <p>The x Aux input is set to 0 in the event of:</p> <ul style="list-style-type: none"> • a rising edge on input Acq with input Ctrl1 at 1, • change of status of input Cde.
3	On the falling edge of input Cde : <ul style="list-style-type: none"> • time-out t2i is launched, • input x changes to 0.

Phase	Description
4	<p>When time out t2i is over:</p> <ul style="list-style-type: none"> ● if the Ctrl2 signal changes to status 1 during time-out interval t2i, the x Aux input stays at 0 (normal situation), ● if the Ctrl2 signal is not received, the x Aux output changes to 1 (type A error signal). ● if the Ctrl2 signal falls back while the Cde input is at 0, the x Aux output changes to 1 (type B error signal). <p>The x Aux input is set to 0 in the event of:</p> <ul style="list-style-type: none"> ● a rising edge on input Acq with input Ctrl2 at 1, ● change of status of input Cde.

Illustration

The illustration below shows the trend diagram of the type 2 command-check function block.

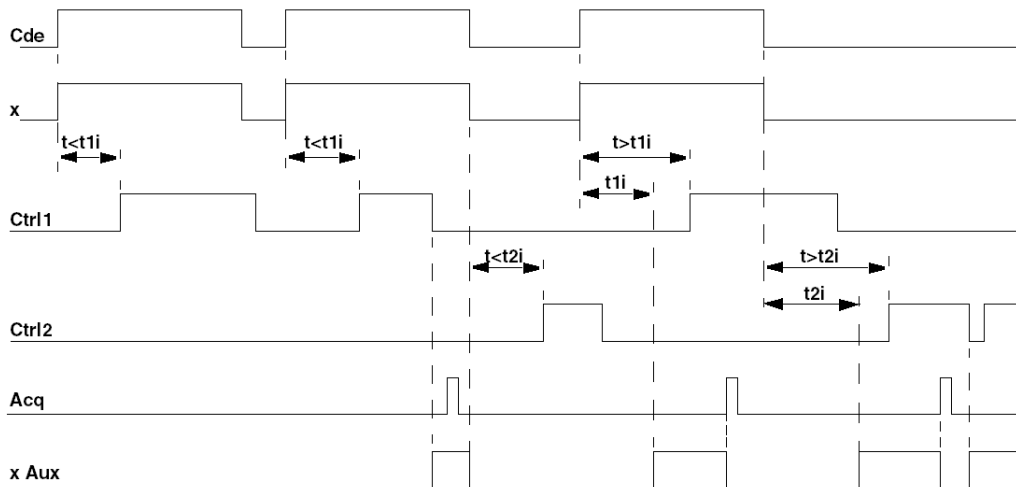

Reflex function block: Command-counting

Role

This function is used to detect a **th** threshold in order to command a positioning action.

Structure

The table below shows the block's different interfaces.

Name	Meaning	Illustration
Cde	Command input.	
Reset	Outputs x and x Aux are set to 0.	
Up	Counting input.	
x	Block's physical output.	
x Aux	Block's internal auxiliary output.	

Operation

This table describes the different operating phases of the command-counting function.

Phase	Description
1	Counter initialized to 0 on the rising edge of the Reset input.
2	On the rising edge of the Cde input, the x input changes to 1. On every rising edge of the Up input, the counter is increased.
3	When threshold th is reached, or if input Cde changes to 0, outputs x and x Aux change to 0.
Note: Input Cde does not influence the counting carried out on the rising edge of the Up input.	

Illustration

The illustration below shows the trend diagram of the command-counting function block.

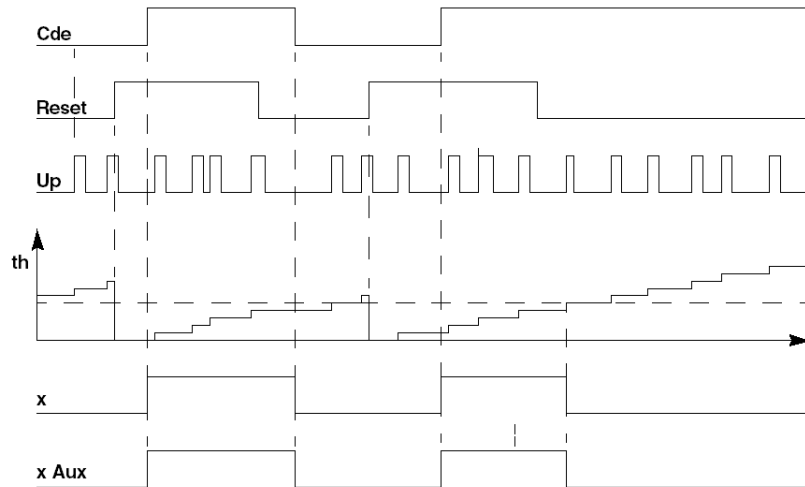

Reflex function block: Fault Signaling

Role

This function is used to indicate a fault, with acknowledgement and clearing.

Structure

The table below shows the block's different interfaces.

Name	Meaning	Illustration
Def	Fault input.	
Acq	Acknowledgement input	
Eff	Clear input	
x	Block's physical output.	
x Aux	Output inactive for this block.	

Operation

This table describes the different operating phases of the Fault Signaling function.

Phase	Description
1	If the Def status is at the high status, the x output oscillates for period $2 \times t1i$.
2	On the rising edge of input Acq : <ul style="list-style-type: none"> ● if the fault persists, the output changes to 1, ● if the fault disappears, the output oscillates for period $2 \times t2i$.
3	On the rising edge of the Eff input, the x output changes to 0. Note: Should the fault still remain, the cycle begins again in phase.
<p>Note: Output x flashes when a fault occurs:</p> <ul style="list-style-type: none"> ● t1i flashes rapidly: fault present and unacknowledged by Acq, ● t2i flashes slowly: fault not present and acknowledged by Acq, ● lit up: fault present and acknowledged by Acq, ● out: last fault cleared by the Eff input after acknowledgement. 	

Illustration

The illustration below shows the trend diagram of the Fault Signaling function with $t_{1i} < t_{2i}$.

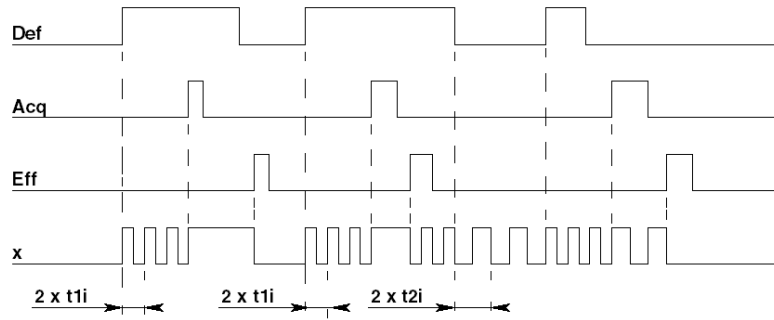

38.4 Modification of internal values using MOD_PARAM

Modification of the internal values using MOD_PARAM function

Presentation

Other than the standard instructions the TSX DMY 28 RFK module also uses a specific instruction MOD_PARAM (see *Unity Pro, Drive control, Block Library*) (Modify parameters) which enables the parameters associated with a single channel to be modified.

NOTE: In order to avoid several simultaneous explicit exchanges for the same index of channels, it is necessary to test the value of the word EXCH_STS of the IODDT (see page 444)

Syntax: MOD_PARAM %CHxy.i (no., value1 , value2 , 0) where:

- i = 16 or 24 (index of the first channel of a group of 8 channels),
- no. = 0 to 7 (index of the channel in the group of channels),
- value1, value2 correspond to the function parameters applied to the output (Timer, PWM, Counter...).

Example: Modification of parameters of channel 18 (value1 = 10 ms (100 x 0.1 ms) , value2 = 500 ms (5000 x 0.1 ms)) MOD_PARAM %CHxy.16 (2, 100 , 5000 , 0)

Glossary

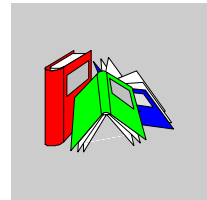

A

AS-i

Actuator Sensor interface.

C

Channel group

Channels of the same type with common parameters. This notion concerns certain application-specific modules such as discrete modules.

CPU

Central Processing Unit: generic name used for Schneider Electric processors

D

Discrete

Discrete I/Os

F

Fipio

Field bus used to connect sensor or actuator type devices.

I

IODDT

Input/Output Derived Data Type

IP67

Family of Schneider Electric hardware products consisting of sealed I/O modules which connect to the FIPIO field bus, used to produce automated systems with distributed I/Os.

M

Momentum

I/O modules using several open standard communication networks.

P

PV

Identifier indicating the product version.

T

TBX

I/O modules remoted on the FIPIO bus.

TSX/PCI57/Atrium

Families of Schneider Electric hardware products.

U

Unity Pro

Programming software of Schneider Electric PLCs.

Index

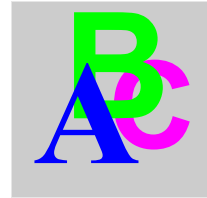

A

ABE-7H08R10, 266
ABE-7H08R11, 266
ABE-7H08R21, 270
ABE-7H08S21, 274
ABE-7H12R10, 268
ABE-7H12R11, 268
ABE-7H12R20, 272
ABE-7H12R21, 272
ABE-7H12R50, 280
ABE-7H12S21, 276
ABE-7H16F43, 284
ABE-7H16R10, 266
ABE-7H16R11, 266
ABE-7H16R20, 270
ABE-7H16R21, 270
ABE-7H16R23, 270
ABE-7H16R30, 278
ABE-7H16R31, 278
ABE-7H16R50, 282
ABE-7H16S21, 274
ABE-7H16S43, 285
ABE-7P16F310, 333
ABE-7P16F312, 334
ABE-7P16T214, 319
ABE-7P16T215, 321
ABE-7P16T318, 331
ABE-7P16T334, 329
ABE-7R08S111/16S111, 287, 289
ABE-7R08S210/16S210, 292, 294
ABE-7R16S212, 297, 298, 308
ABE-7R16T210/P16T210, 312

ABE-7R16T212/P16T212, 314
ABE-7R16T230, 316
ABE-7R16T231, 317
ABE-7R16T330/P16T330, 323
ABE-7R16T332/P16T332, 325
ABE-7R16T370, 327
ABE-7S08S2B0, 310
ABE-7S08S2B1, 307
ABE-7S16S2B0/S2B2, 304
ABR-7xxx relays, 340
ABS-7Exx relays, 341

C

changing output states, 454
channel data structure for discrete I/O modules
 T_DIS_EVT, 436, 437
 T_DIS_IN_GEN, 432
 T_DIS_IN_STD, 433, 434
 T_DIS_OUT_GEN, 439
 T_DIS_OUT_REFLEX, 443, 444
 T_DIS_OUT_STD, 440, 441
configuring discrete inputs, 403
configuring discrete outputs, 403
configuring discrete outputs, 407
connection bases, 249, 300

D

debugging discrete inputs, 449
debugging discrete outputs, 449

diagnostics for discrete inputs, *459*
diagnostics for discrete outputs, *459*

E

event management
 TSXDEY16FK, *120*

F

fallback mode for discrete outputs, *418*
fault processing, *55*
filtering discrete inputs
 TSXDEY16FK, *117*
 TSXDMY28RFK, *117*
 TSXDMY28RFK, *117*
filtering parameters, *417*
forcing, *453*
fusing, *183*

H

HE10 connectors, *37*

L

latching discrete inputs
 TSXDEY16FK, *118*
 TSXDMY28FK, *118*

M

masking, *455*
Modification of values using MOD_PARAM
 Reflex discrete specific application, *521*

P

parameters settings, *422*
protecting relay contacts
 TSXDSY08R5, *175*
 TSXDSY16R5, *175*

R

reactivating discrete outputs, *419, 456*
reflex functions, *475*
 TSXDMY28RFK, *241*
reflex modules
 configuring, *467*
 function parameters, *415*
 TSXDMY28RFK, *463*
relays, *335, 342*

S

safety modules, *344*
 diagnostics, *379*

T

T_DIS_EVT, *436, 437*
T_DIS_IN_GEN, *432*
T_DIS_IN_STD, *433, 434*
T_DIS_OUT_GEN, *439*
T_DIS_OUT_REFLEX, *443, 444*
T_DIS_OUT_STD, *440, 441*
task parameter, *413*
TELEFAST 2, *249*
temperature derating, *77*
terminal blocks
 connecting, *44*
TSX CPP 301
 Connection to TSX PAY 2•2, *370*
TSXDEY08D2, *67, 68, 69*
TSXDEY16A2, *87, 88, 89, 91*
TSXDEY16A3, *97, 98, 99*
TSXDEY16A4, *103, 104, 105*
TSXDEY16A5, *109, 110, 111*
TSXDEY16D2, *73, 74, 75*
TSXDEY16D3, *81, 82, 83*
TSXDEY16FK, *115, 116, 121*
TSXDEY32D2K, *125, 126, 127*
TSXDEY32D3K, *131, 132, 133*
TSXDEY64D2K, *137, 138, 139*
TSXDMY28FK, *231, 232, 233*
TSXDMY28RFK, *239, 240, 242*
TSXDSY08R4D, *181, 182, 186*
TSXDSY08R5, *173, 174, 176*

TSXDSY08R5A, 189, 190, 191
TSXDSY08S5, 201, 202, 203
TSXDSY08T2, 143, 144, 145
TSXDSY08T22, 149, 150, 151
TSXDSY08T31, 155, 156, 157
TSXDSY16R5, 195, 196, 197
TSXDSY16S4, 213, 214, 215
TSXDSY16S5, 207, 208, 209
TSXDSY16T2, 161, 162, 163
TSXDSY16T3, 167, 168, 169
TSXDSY32T2K, 219, 220, 221
TSXDSY64T2K, 225, 226, 227
TSXPAY262, 358, 365, 389, 391
TSXPAY282, 358, 365, 394, 396

W

wiring precautions for safety modules, 360
wiring precautions, 40
wiring safety modules, 361

