

Industrial Automation

(Automação de Processos Industriais)

Analysis of Discrete Event Systems

<http://users.isr.ist.utl.pt/~jag/courses/api19b/api1920.html>

Prof. Paulo Jorge Oliveira, original slides
Prof. José Gaspar, rev. 2019/2020

Syllabus:

Chap. 6 – Discrete Event Systems [2 weeks]

...

Chap. 7 – Analysis of Discrete Event Systems [2 weeks]

Properties of DESs.

Methodologies to analyze DESs:

- * The Reachability tree.**
- * The Method of Matrix Equations.**

...

Chap. 8 – DESs and Industrial Automation [1 week]

Some pointers to Discrete Event Systems

History: <http://prosys.changwon.ac.kr/docs/petrinet/1.htm>

Tutorial: <http://vita.bu.edu/cgc/MIDEDS/>
<http://www.daimi.au.dk/PetriNets/>

Analyzers,
and
Simulators: <http://www.ppgia.pucpr.br/~maziero/petri/arp.html> (in Portuguese)
<http://wiki.daimi.au.dk:8000/cpntools/cpntools.wiki>
<http://www.informatik.hu-berlin.de/top/pnk/download.html>

Bibliography: * Cassandras, Christos G., "**Discrete Event Systems - Modeling and Performance Analysis**", Aksen Associates, 1993.
* Peterson, James L., "**Petri Net Theory and the Modeling of Systems**", Prentice-Hall, 1981
* **Petri Nets and GRAFCET: Tools for Modelling Discrete Event Systems**
R. DAVID, H. ALLA, New York : PRENTICE HALL Editions, 1992

Properties of Discrete Event Systems

1. Reachability

Given a Petri net $C=(P, T, I, O, \mu_0)$ with initial marking μ_0 , the **set of all markings** that can be obtained starting from μ is the **Reachable Set**, $R(C, \mu)$.

Note: **in general $R(C, \mu)$ is infinite!**

How to describe and compute $R(C, \mu)$?

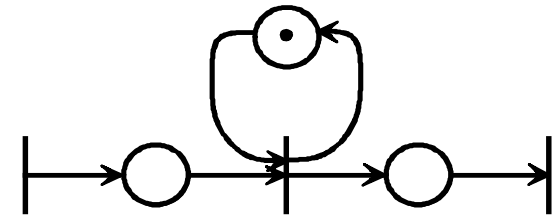

Reachability problem: Given a Petri net C with initial marking μ_0 , does the marking μ' belong to the set of all markings that can be obtained, i.e. $\mu' \in R(C, \mu)$?

Property usage: State μ **belongs / does not belong** to $R(C, \mu_0)$.

usage2: State μ **is / is not reachable**.

usage3: Net C has a **finite / infinite** Reachable Set.

Properties of Discrete Event Systems

2. Coverability

Given a Petri net $C=(P, T, I, O, \mu_0)$ with initial marking μ_0 and states $\mu, \mu' \in R(C, \mu_0)$ then **μ' is covered by μ** if **$\mu'(i) \leq \mu(i)$** , for all places $p_i \in P$.

Equivalently, one says **μ covers μ'** .

Property usages:

State μ' **covers / does not cover** state μ .

State μ **is / is not covered** by state μ' .

State μ **is / is not coverable** by other reachable states.

Note, μ' not covered by μ does not imply μ' covers μ .

*Is it possible to use this property to help on the search for the reachable set? **Yes!***

Details after some few slides.

Properties of Discrete Event Systems

3. Safeness

A place $p_i \in P$ of the Petri net $C=(P, T, I, O, \mu_0)$ **is safe** if
 for all $\mu' \in R(C, \mu_0)$: $\mu_i' \leq 1$.

A Petri net **is safe** if all its places are safe.

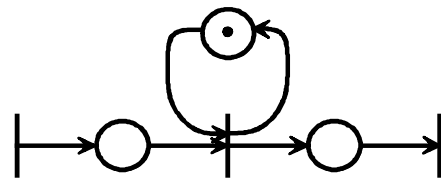

Petri net not safe

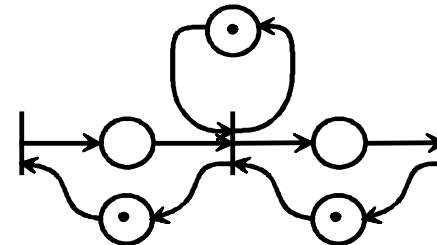

Petri net safe

Property usage: Place p_i / Net C **is / is not safe.**

Properties of Discrete Event Systems

4. Boundedness

Given a Petri net $C=(P, T, I, O, \mu_0)$, a **place $p_i \in P$ is k -bounded** if $\mu_i' \leq k$ for all $\mu'=(\mu_1', \dots, \mu_i', \dots, \mu_N') \in R(C, \mu_0)$.

A Petri net is **k -bounded** if all places are k -bounded.

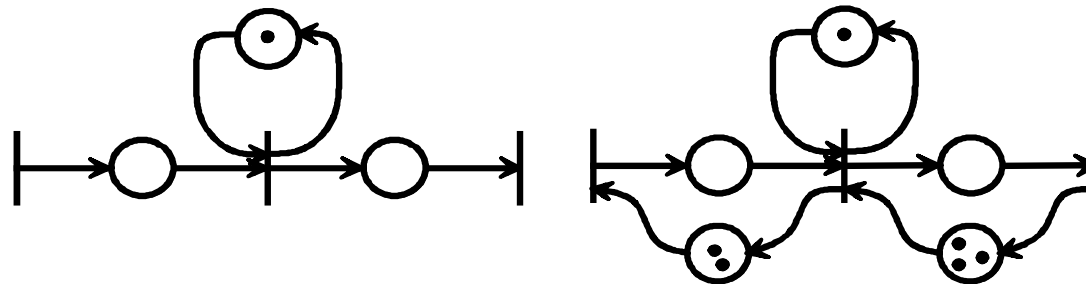

Petri net not bounded

Petri net 3-bounded

Property usage: Place p_i / Net C **is / is not k -bounded.**

Properties of Discrete Event Systems

5. Conservation

A Petri net $C=(P, T, I, O, \mu_0)$ is **strictly conservative** if for all $\mu' \in R(C, \mu)$

$$\sum_{p_i \in P} \mu'(p_i) = \sum_{p_i \in P} \mu(p_i)$$

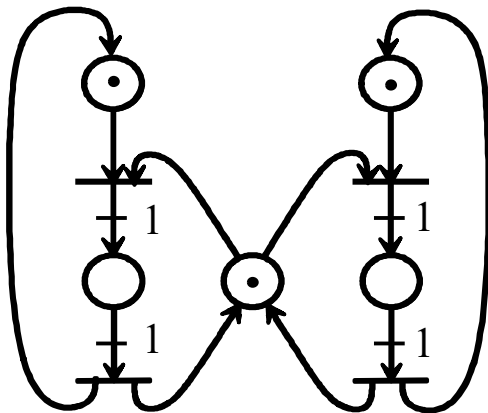

Petri net **not strictly conservative**

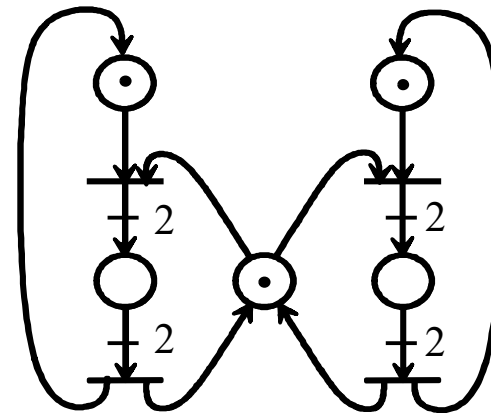

Petri net **strictly conservative**

Property usage: Net C **is / is not (strictly) conservative.**

Properties of Discrete Event Systems

6. Liveness

A transition t_j is live of

Level 0 - if it can **never** be fired (transition is *Dead*).

Level 1 - if it is **potentially firable** an upper-bounded number of times,
i.e. if there exists $\mu' \in R(C, \mu)$ such that t_j is enabled in μ' .

Level 2 - if for every integer n , there exists a firing sequence such that t_j
occurs n times.

Level 3 - if there exists an infinite firing sequence such that t_j **occurs infinite times**.

Level 4 - if for each $\mu' \in R(C, \mu)$ there exist a sequence σ such that the transition
 t_j is enabled (transition is *Live*).

Properties of Discrete Event Systems

Example of liveness of transitions

- t_0 is of level 0.
- t_1 is of level 1.
- t_2 is of level 2.
- t_3 is of level 3.
- *this net does not have level 4 transitions.*

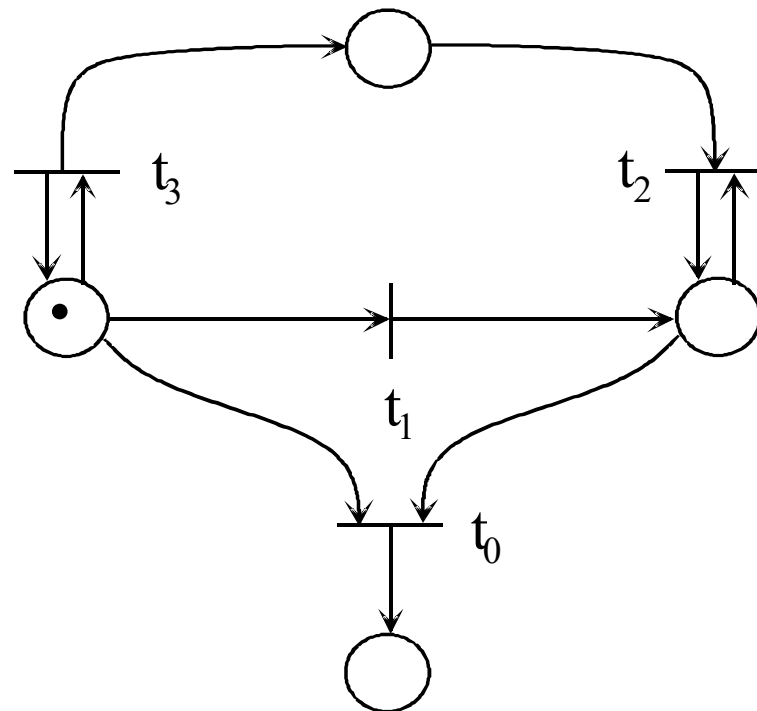

Properties of Discrete Event Systems

Reachability problem

Given a Petri net $C=(P, T, I, O, \mu_0)$ with initial marking μ_0 and a marking μ' , is $\mu' \in R(C, \mu_0)$ reachable?

Analysis methods:

0- Brute force...

1- Reachability tree

2- Matrix equations

Analysis Methods, 1- Reachability Tree

Reachability Tree - construction *[Peterson81, §4.2.1]*

A reachability tree is a **tree of reachable markings**.

Tree nodes are states. The root node is the initial state (marking).

It is constituted by three types of nodes:

- **Terminal** no state changes after a terminal state
- **Interior** state can change after
- **Duplicated** state already found in the tree

The **infinity marking symbol** (ω) is introduced whenever a **marking covers other**. This symbol allows obtaining finite trees.

*The reachability tree is useful to study properties previously introduced.
Some examples later.*

Analysis Methods

Reachability Tree - construction [Peterson81, §4.2.1]

Algebra of the infinity symbol (ω):

For every positive integer a the following relations are verified:

1. $\omega + a = \omega$
2. $\omega - a = \omega$
3. $a < \omega$
4. $\omega \leq \omega$

Reachability Tree and Deadlocks

Theorem - If there exist terminal nodes in the reachability tree then the corresponding Petri net has *deadlocks*.

Analysis Methods

Example of reachability tree:

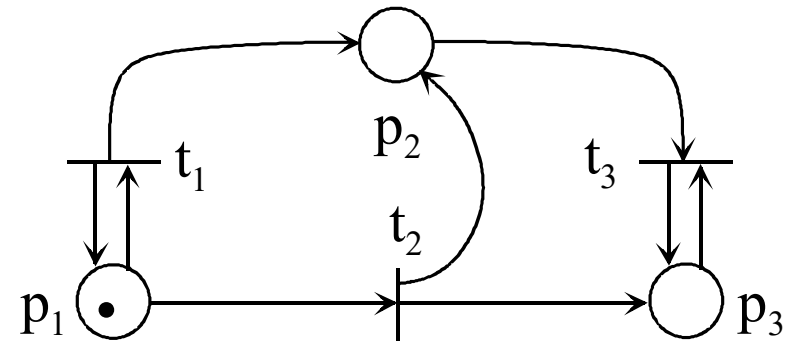
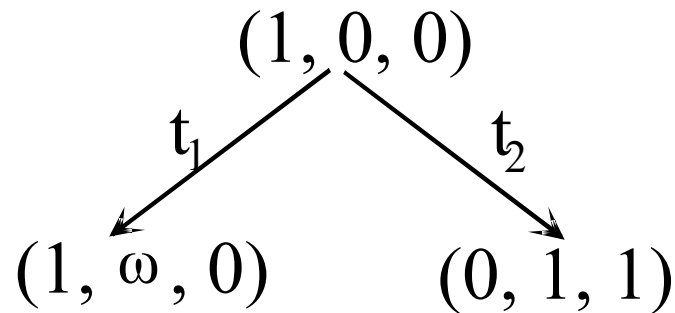

After t_1 one obtains $(1, 0, 0)$ which **is covered** by $(1, 1, 0)$. Hence one introduces the **infinity symbol, ω** and writes the state as **$(1, \omega, 0)$** .

Analysis Methods

Example of reachability tree:

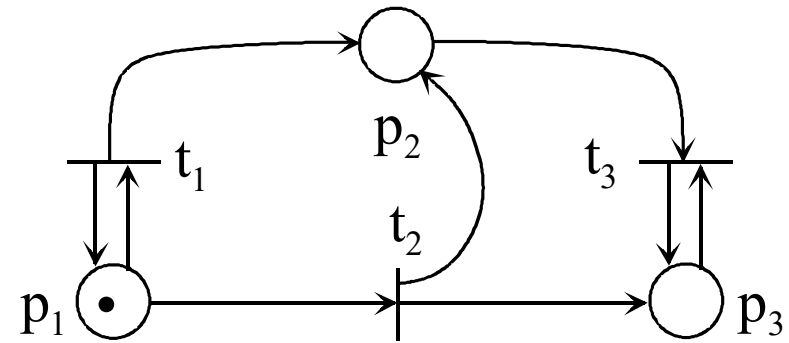
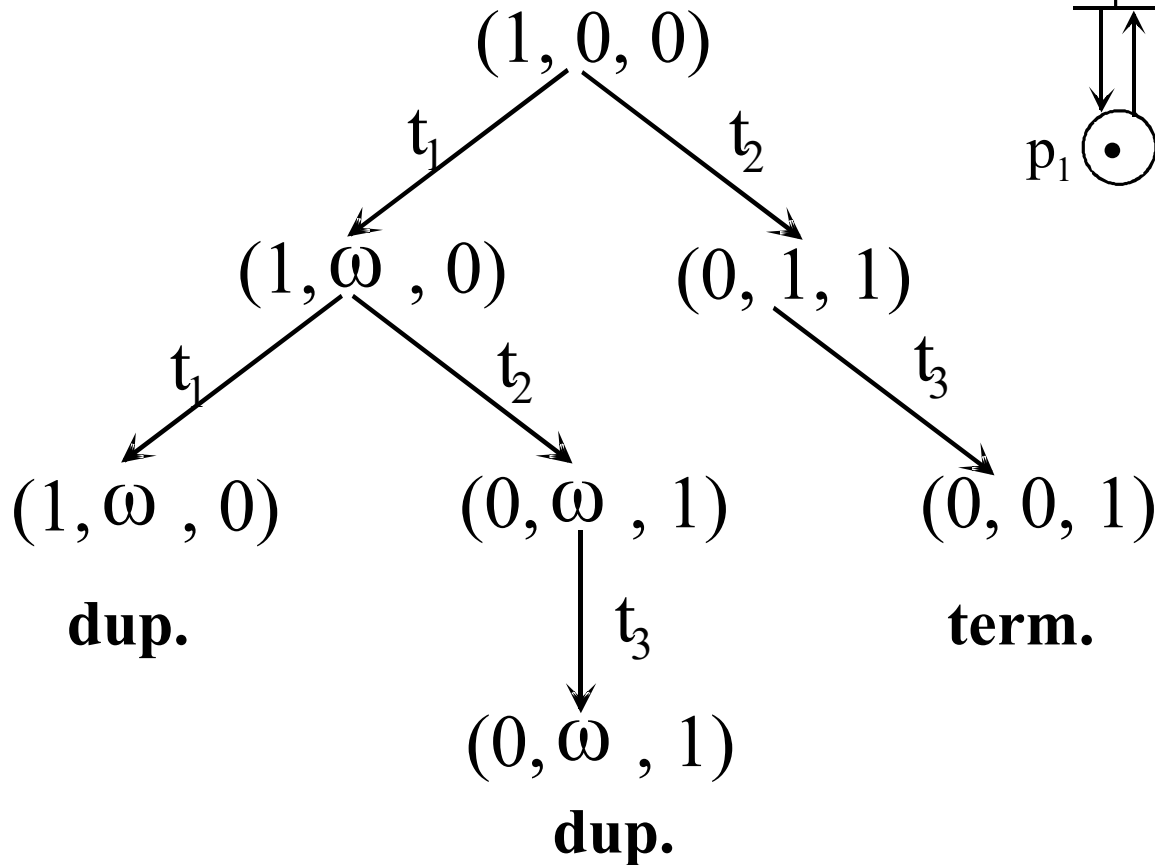

We can conclude immediately that there are DEADLOCKS!

Analysis Methods

Reachability Tree vs Coverability Tree

[Cassandras08, §4.4.2]

Considering a Petri net the **reachability tree** is "a tree whose root node is (...), then examine all transitions that can fire from this state, define new nodes in the tree, and repeat until all possible reachable states are identified."

"The reachability tree (...) may be infinite. A finite representation (...) is possible, but at the expense of losing some information. The finite version of an infinite reachability tree will be called a **coverability tree**."

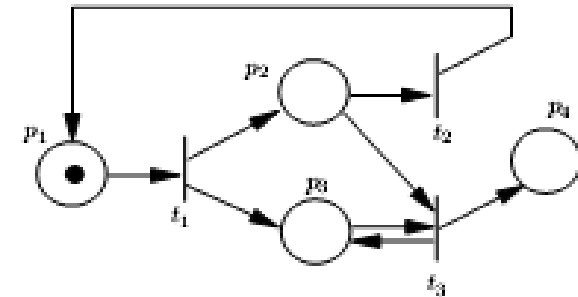

Reachability tree , Coverability tree

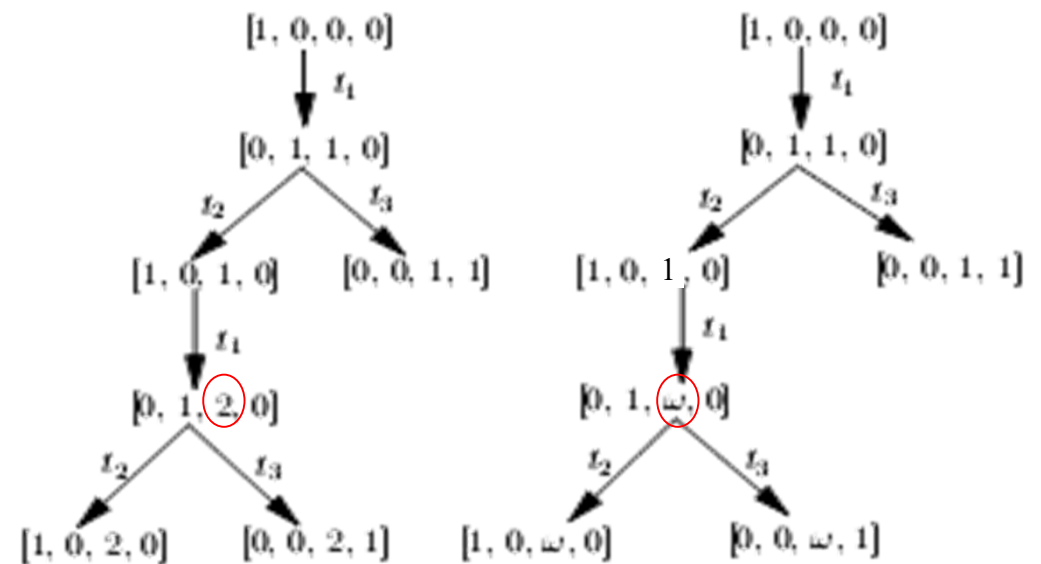

(In this course we use Peterson's terminology, i.e. "reachability tree" in both cases)

Example1: simple Petri net, properties?

$$(P, T, A, w, x_0)$$

$$P = \{p_1, p_2, p_3, p_4, p_5\}$$

$$T = \{t_1, t_2, t_3, t_4\}$$

$$A = \{(p_1, t_1), (t_1, p_2), (t_1, p_3), (p_2, t_2), (p_3, t_3), (t_2, p_4), (t_3, p_5), (p_4, t_4), (p_5, t_4), (t_4, p_1)\}$$

$$w(p_1, t_1) = 1, w(t_1, p_2) = 1, w(t_1, p_3) = 1, w(p_2, t_2) = 1$$

$$w(p_3, t_3) = 2, w(t_2, p_4) = 1, w(t_3, p_5) = 1, w(p_4, t_4) = 3$$

$$w(p_5, t_4) = 1, w(t_4, p_1) = 1$$

$$x_0 = \{1, 0, 0, 2, 0\}$$

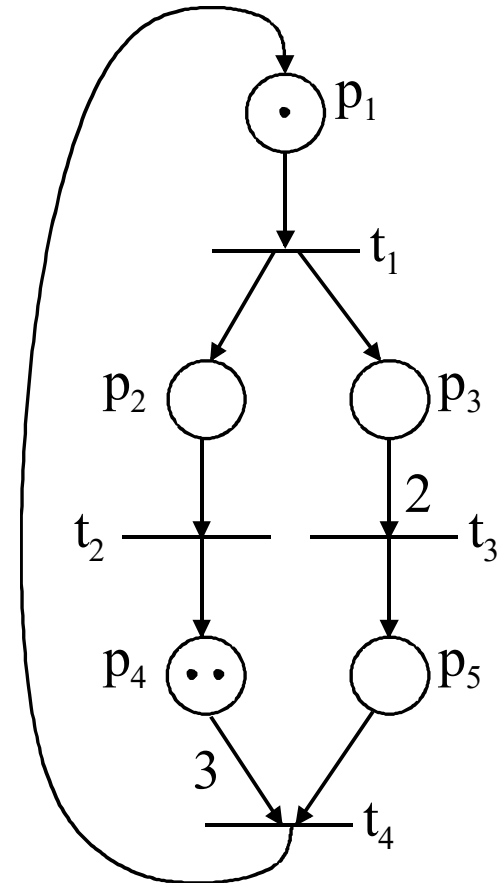

Example2: simple automation system modeled using PNs, properties?

An automatic soda selling machine accepts 50c and \$1 coins and sells 2 types of products: SODA A, that costs \$1.50 and SODA B, that costs \$2.00.

Assume that the money return operation is omitted.

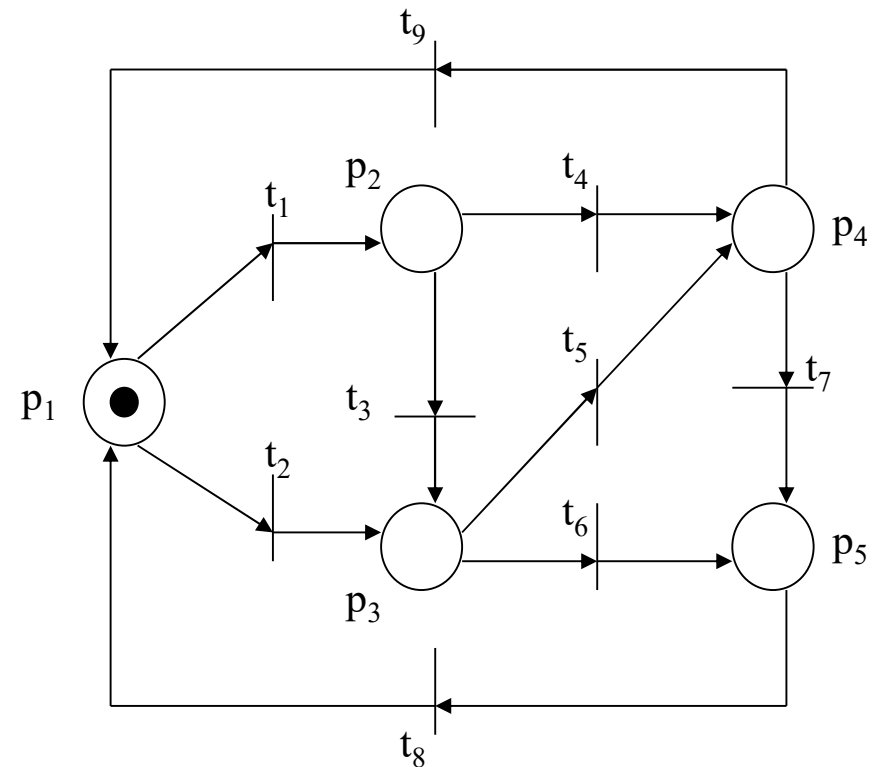

p_1 : machine with \$0.00;
 t_1 : coin of 50 c introduced;
 t_8 : SODA B sold.

Example3:
(counter-example)

Different reachable sets
but the
same reachability tree

Decidability Problem:

Can one reach (1,0,1)? **Yes** in one net,
No in the other one. Simple to answer in
this net, but undecidable in general due
to the symbol ω .

*The reachability tree does not ensure
decidability of state reachability.*

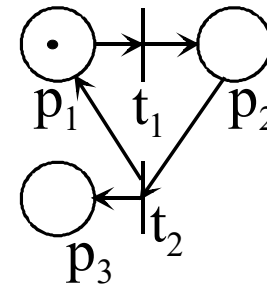

(1, 0, 0)



(0, 1, 0)



(1, 0, ω)



(0, 1, ω)



(1, 0, ω)

dup.

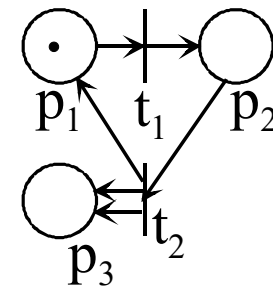

(1, 0, 0)



(0, 1, 0)



(1, 0, ω)



(0, 1, ω)



(1, 0, ω)

dup.

Alternative definition (#3) of a Petri net

A marked Petri net is a *5-tuple* [Iordache06]

$$(\mathbf{P}, \mathbf{T}, \mathbf{D}^-, \mathbf{D}^+, \mu_0) \quad \text{or} \quad (\mathbf{P}, \mathbf{T}, \mathbf{Pre}, \mathbf{Post}, \mu_0)$$

where:

P - set of places

T - set of transitions

Pre - pre conditions matrix

$$\mathbf{Pre} : \mathbf{P} \times \mathbf{T} \rightarrow \mathbf{N}$$

Post - post conditions matrix

$$\mathbf{Post} : \mathbf{P} \times \mathbf{T} \rightarrow \mathbf{N}$$

μ_0 - initial marking

$$\mu_0 : \mathbf{P} \rightarrow \mathbf{N}$$

Note: $\mathbf{D} = \mathbf{D}^+ - \mathbf{D}^- = \mathbf{Post} - \mathbf{Pre}$ is named the **incidence matrix**.

[Iordache06] "Supervisory control of concurrent systems: a Petri net structural approach", Marian Iordache and Panos J. Antsaklis, Birkhauser Boston, 2006

Alternative definition (#3), how to build the **Incidence Matrix, D** ?

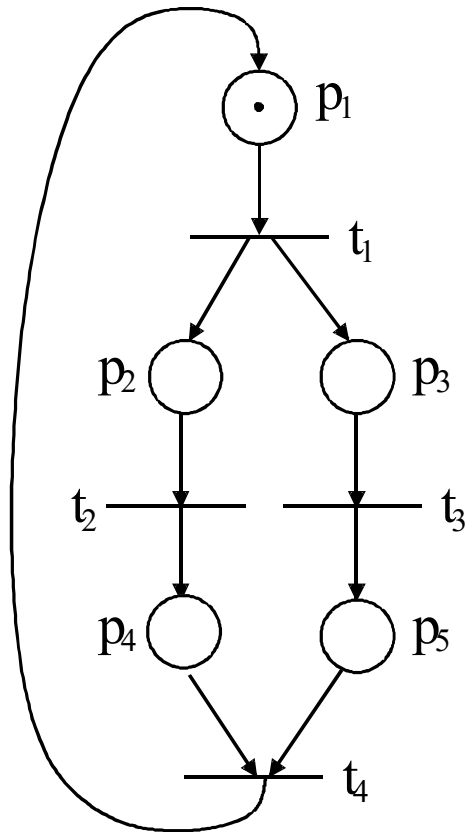

Petri net (P, T, D^-, D^+, μ_0) , $D = D^+ - D^-$

Set of places $P = \{p_1, p_2, p_3, p_4, p_5\}$

Set of transitions $T = \{t_1, t_2, t_3, t_4\}$

$$\begin{array}{l}
 p_1 \\
 p_2 \\
 p_3 \\
 p_4 \\
 p_5
 \end{array}
 \leftarrow
 \begin{array}{c}
 t_1 \quad t_2 \quad t_3 \quad t_4 \\
 D = \begin{bmatrix}
 -1 & 0 & 0 & 1 \\
 1 & -1 & 0 & 0 \\
 1 & 0 & -1 & 0 \\
 0 & 1 & 0 & -1 \\
 0 & 0 & 1 & -1
 \end{bmatrix}
 \end{array}$$

Read the example marked by the arrows as “firing t_1 takes a mark from p_1 and adds a mark to p_2 and adds another mark to p_3 ”.

Alternative definition (#3) of a Petri net, example **arc weights**

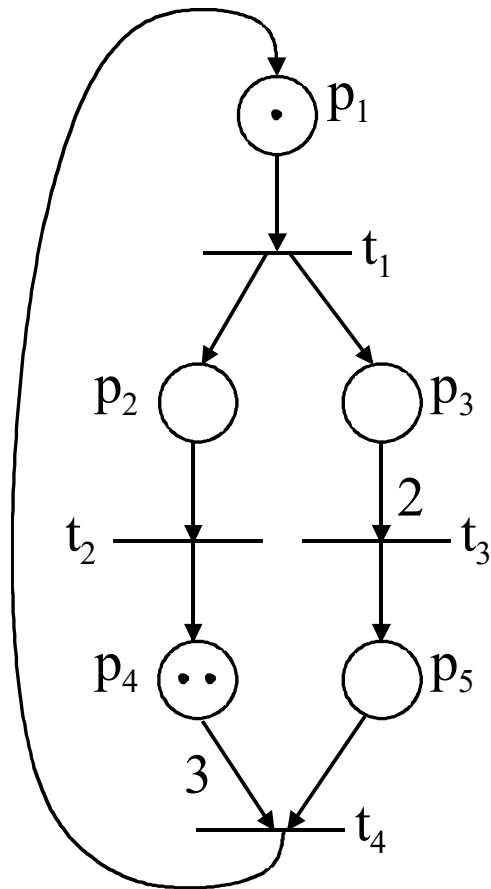

$$(P, T, D^-, D^+, \mu_0)$$

$$P = \{p_1, p_2, p_3, p_4, p_5\}$$

$$T = \{t_1, t_2, t_3, t_4\}$$

$$D = \begin{bmatrix} -1 & & & +1 \\ +1 & -1 & & \\ +1 & & -2 & \\ & +1 & & -3 \\ & & +1 & -1 \end{bmatrix}$$

$$\mu_0 = \{1, 0, 0, 2, 0\}$$

$$D^+ = \max(0, D)$$

$$= \begin{bmatrix} & & & 1 \\ 1 & & & \\ 1 & & & \\ & 1 & & \\ & & 1 & \end{bmatrix}$$

$$D^- = -\min(0, D)$$

$$= \begin{bmatrix} 1 & & & \\ & 1 & & \\ & & 2 & \\ & & & 3 \\ & & & 1 \end{bmatrix}$$

Analysis Methods, 2- MME

Method of the Matrix Equations (MME) of State Evolution

The dynamics of the Petri net state can be written in compact form as:

$$\mu(k+1) = \mu(k) + Dq(k)$$

This methodology can also be used to study the other properties previously introduced.

Requires some thought... ;)

where:

$\mu(k+1)$ - marking to be reached

$\mu(k)$ - initial marking

$q(k)$ - **firing vector** (transitions)

D - **incidence matrix**. Accounts the balance of tokens, giving the transitions fired.

Analysis Methods, 2- MME

Method of the Matrix Equations (MME) of State Evolution

For a Petri net with n places and m transitions

$$\mu \in N_0^n$$

$$q \in N_0^m$$

$$\boxed{D = D^+ - D^-}, \quad D \in Z^{n \times m}, \quad D^+ \in N_0^{n \times m}, \quad D^- \in N_0^{n \times m}$$

The **enabling firing rule** is $\boxed{\mu \geq D^- q}$

Can also be written in compact form as the inequality $\mu + Dq \geq 0$, interpreted element-by-element.

Note: unless otherwise stated in this course all vector and matrix inequalities are read element-by-element.

Analysis Methods

Properties that can be studied immediately with the Method of Matrix Equations:

- **Reachability**

Theorem, Sufficient Condition for *No Reachability* :

if the problem of finding the transition firing vector that drives the state of a Petri net from μ to state μ' **has no solution, resorting to the method of matrix equations**, then the problem of reachability of μ' **does not have solution.**

- **Conservation** – the weight vector is a by-product of the MME.
- **Temporal invariance** – cycles of operation can be found.

Analysis Methods

1. Reachability

Reachability problem: Given a Petri net C with initial marking μ_0 , does the marking μ' belong to the set of all markings that can be obtained, i.e. $\mu' \in R(C, \mu)$?

Example using the method of matrix equations $\mu(k+1) = \mu(k) + Dq(k)$

Given the net:

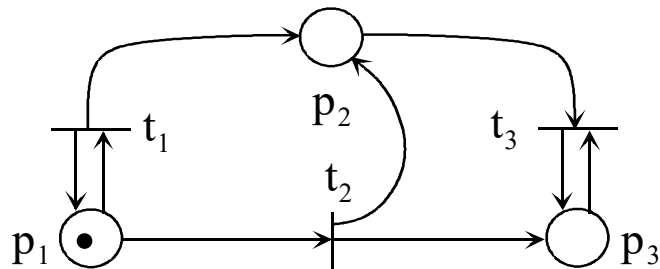

$$D = \begin{bmatrix} 0 & -1 & 0 \\ 1 & 1 & -1 \\ 0 & 1 & 0 \end{bmatrix} \quad \mu(k) = \begin{bmatrix} 1 \\ 0 \\ 0 \end{bmatrix}$$

Problem:

is $\mu(k+1)$ reachable?

e.g. $\mu(k+1) = \begin{bmatrix} 1 \\ 3 \\ 0 \end{bmatrix}$,

Solution, find $q(k)$:

(note using σ_{ii} to avoid using q_i and confusing with $q(i)$; this is to drop soon)

$$q(k) = \begin{bmatrix} \sigma_{t1} \\ \sigma_{t2} \\ \sigma_{t3} \end{bmatrix} \quad \begin{cases} 1 = 1 - \sigma_{t2} \\ 3 = \sigma_{t1} + \sigma_{t2} - \sigma_{t3} \\ 0 = \sigma_{t2} \end{cases} \quad \begin{cases} \sigma_{t2} = 0 \\ \sigma_{t1} - \sigma_{t3} = 3 \end{cases} \quad \text{Verify!}$$

$\exists q$ such that $Dq(k) = \mu(k+1) - \mu(k)$ is a **necessary but not sufficient** condition.

Example of a Petri net

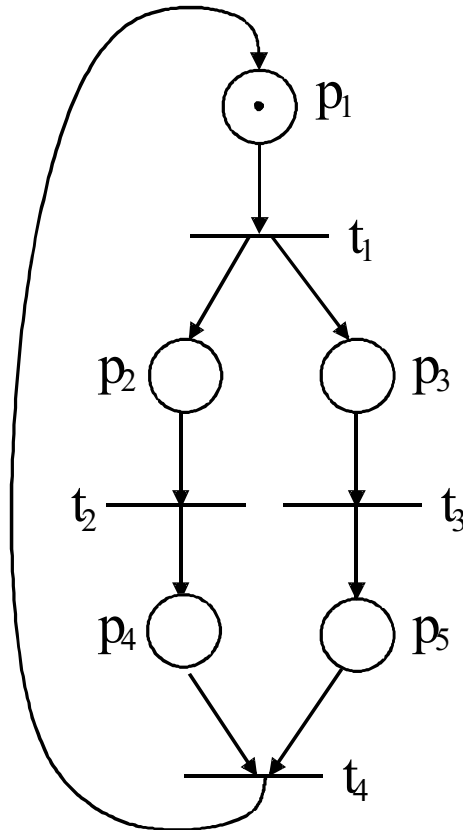

2. Conservation

To maintain the (weighted) number of tokens one writes:

$$w^T \mu' = w^T \mu + w^T Dq$$

and therefore:

$$w^T D = 0 \quad \exists x > 0 \text{ is a *necessary and sufficient* condition}$$

$$D = \begin{bmatrix} -1 & 0 & 0 & 1 \\ 1 & -1 & 0 & 0 \\ 1 & 0 & -1 & 0 \\ 0 & 1 & 0 & -1 \\ 0 & 0 & 1 & -1 \end{bmatrix} \quad \begin{cases} -w_1 + w_2 + w_3 = 0 \\ -w_2 + w_4 = 0 \\ -w_3 + w_5 = 0 \\ w_1 - w_4 - w_5 = 0 \end{cases} \quad \begin{cases} w_1 = w_2 + w_3 \\ w_2 = w_4 \\ w_3 = w_5 \\ - \end{cases}$$

This example has a solution in the form of an **undetermined system of equations**, where we can choose:

$$w^T = [2 \quad 1 \quad 1 \quad 1 \quad 1].$$

Example of a Petri net

3. Temporal invariance

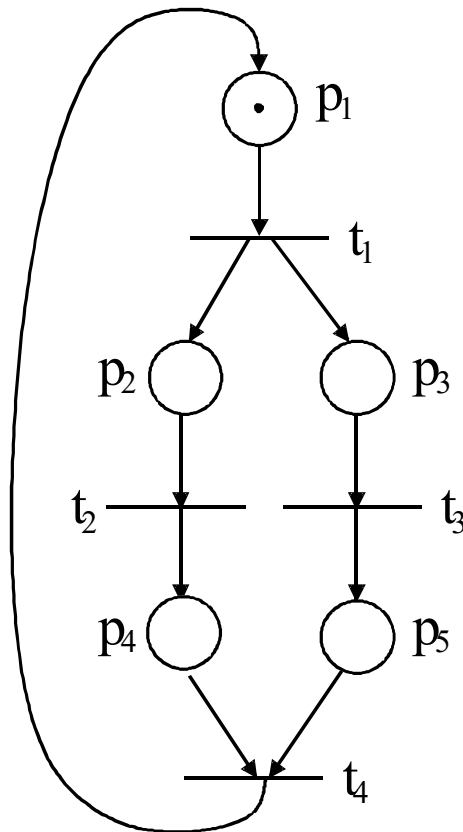

To determine the transition firing vectors that make the Petri net return to the same state(s):

$$Dq = 0$$

$\exists q$ is a *necessary (not sufficient) condition*

$$D = \begin{bmatrix} -1 & 0 & 0 & 1 \\ 1 & -1 & 0 & 0 \\ 1 & 0 & -1 & 0 \\ 0 & 1 & 0 & -1 \\ 0 & 0 & 1 & -1 \end{bmatrix}, \quad q = \begin{bmatrix} q_1 \\ q_2 \\ q_3 \\ q_4 \end{bmatrix} \quad \begin{cases} -q_1 + q_4 = 0 \\ q_1 - q_2 = 0 \\ q_1 - q_3 = 0 \\ q_2 - q_4 = 0 \\ q_3 - q_4 = 0 \end{cases}$$

This example has a solution in the form of an **undetermined system of equations** from which we can choose e.g.:

$$q = [1 \ 1 \ 1 \ 1]^T .$$

Example for the analysis of properties:

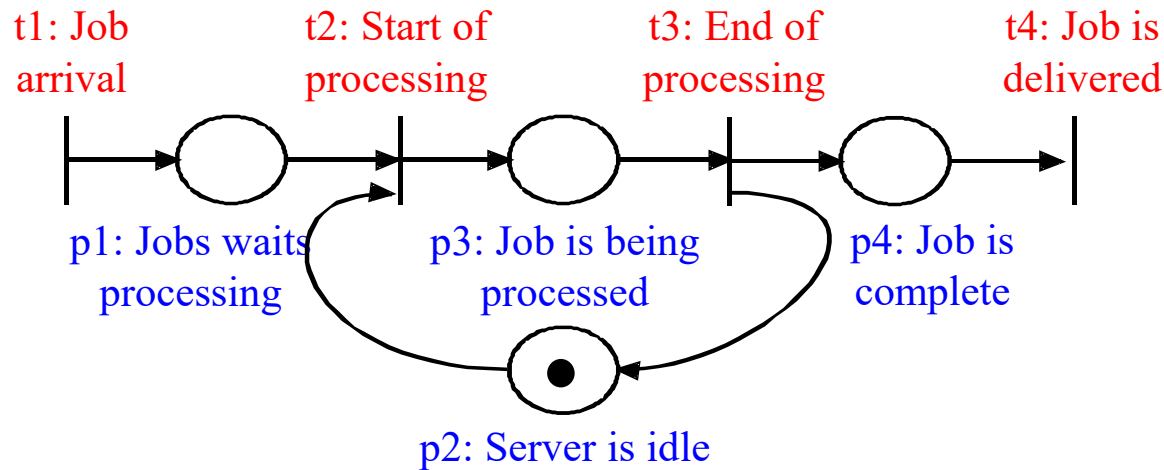

Event	Pre-conditions	Pos-conditions
t1	-	p1
t2	p1, p2	p3
t3	p3	p4, p2
t4	p4	-

Q: Exists **conservation** ?

A: Find w such that $w^T \cdot D = 0$
 if $\exists w > 0$ then net is conservative
 else it is not conservative

$$D = \begin{bmatrix} 1 & -1 & & \\ & -1 & 1 & \\ & 1 & -1 & \\ & & 1 & -1 \end{bmatrix}$$

$$w^T = [w_1 \ w_2 \ w_3 \ w_4] = ?$$

Q2: What changes if initial marking in p2 is zero?

Discrete Event Systems

Example of a simple automation system modeled using PNs

An automatic soda selling machine accepts
 50c and \$1 coins and
 sells 2 types of products:
 SODA A, that costs \$1.50 and
 SODA B, that costs \$2.00.

Assume that the money return operation is omitted.

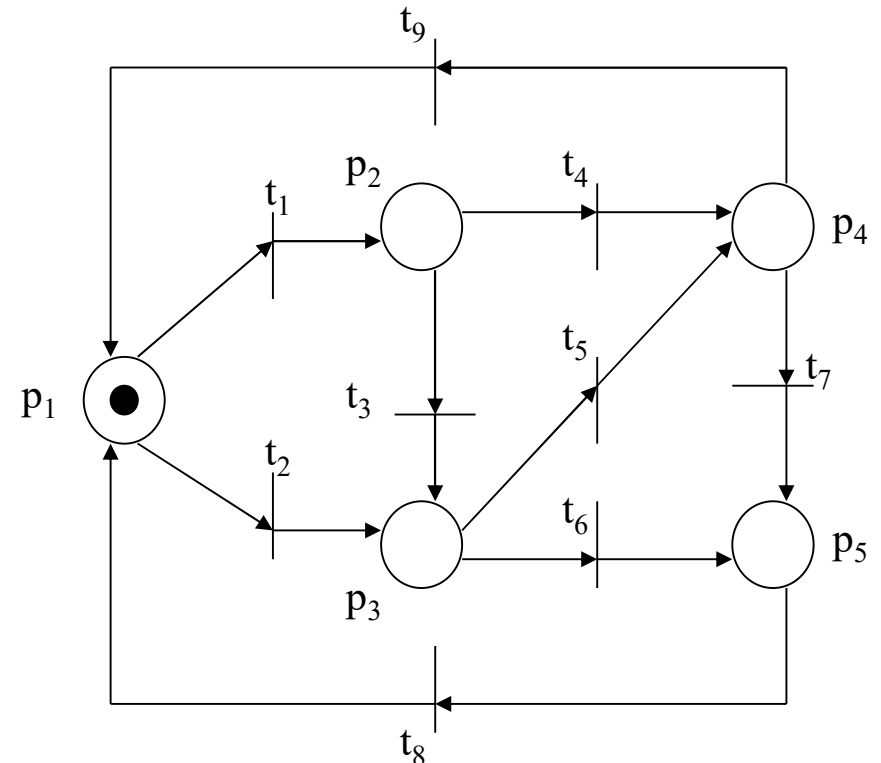

p_1 : machine with \$0.00;
 t_1 : coin of 50 c introduced;
 t_8 : SODA B sold.

Q: Are there transition firing vectors that make the Petri net return to the same state? In other words, does the Petri net have cycles of operation?

Discrete Event Systems

Example of a simple automation system modeled using PNs

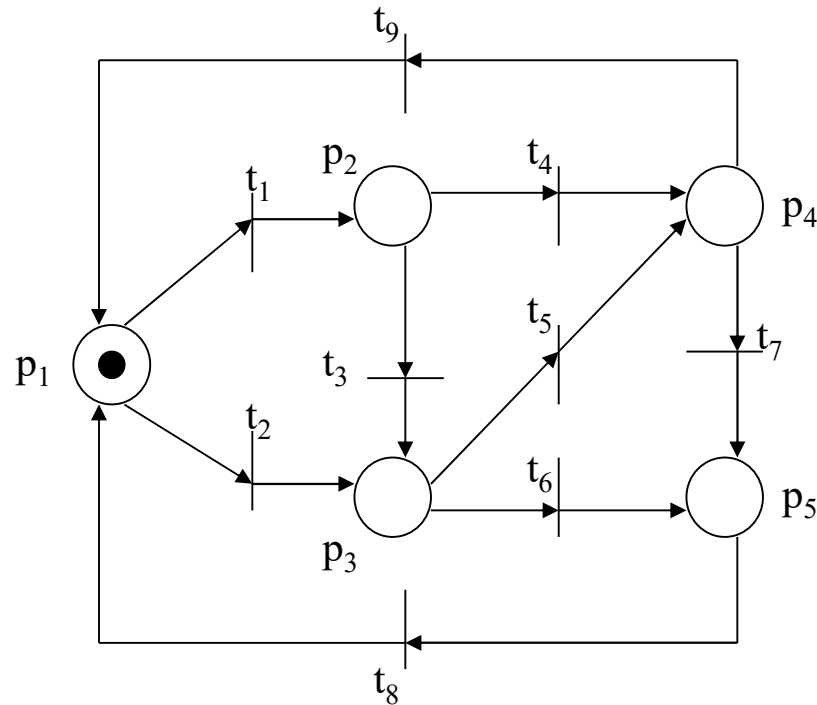

$$D = \begin{bmatrix} -1 & -1 & 0 & 0 & 0 & 0 & 0 & 1 & 1 \\ 1 & 0 & -1 & -1 & 0 & 0 & 0 & 0 & 0 \\ 0 & 1 & 1 & 0 & -1 & -1 & 0 & 0 & 0 \\ 0 & 0 & 0 & 1 & 1 & 0 & -1 & 0 & -1 \\ 0 & 0 & 0 & 0 & 0 & 1 & 1 & -1 & 0 \end{bmatrix}$$

Time invariance ? Find q such that $D \cdot q = 0$

```
>> q = null( D, 'r' )
q =
    1    -1    1    0    1
   -1    1   -1    1    0
    1    0    0    0    0
    0   -1    1    0    1
    0    1    0    0    0
    0    0   -1    1    0
    0    0    1    0    0
    0    0    0    1    0
    0    0    0    0    1

>> q(:,1) = q(:,1) + q(:,4) ;
>> q(:,2) = q(:,2) + q(:,5) ;
>> q(:,3) = q(:,3) + q(:,4) ;
q =
    1    0    1    0    1
    0    1    0    1    0
    1    0    0    0    0
    0    0    1    0    1
    0    1    0    0    0
    1    0    0    1    0
    0    0    1    0    0
    1    0    1    1    0
    0    1    0    0    1
```

Note: there are more solutions; see function `invar(D)` of the SPNBOX toolbox