

Industrial Automation

(Automação de Processos Industriais)

Introduction to PLCs

<http://users.isr.ist.utl.pt/~jag/courses/api1920/api1920.html>

Prof. Paulo Jorge Oliveira, original slides

Prof. José Gaspar, rev. 2019/2020

Syllabus:

Chap. 1 – Introduction to Automation [1 week]

...

Chap. 2 – Introduction to PLCs [2 weeks]

Internal architecture and functional structure.

Input / output interfaces. Interconnection of PLCs .

Components of Programmable Logic Controllers (PLCs).

...

Chap. 3 – PLCs Programming Languages [2 weeks]

Some resources available online on PLCs

History : <http://www.plcs.net/chapters/history2.htm>

Tutorial: <http://www.koldwater.com>
<http://www.htservices.com/Tutorials/plctutorial1.htm>
<http://www.sea.siemens.com/step/templates/lesson.mason?plcs:1:1:1>

Simulators: <http://thelearningpit.com/plc/psim/psim.html>
<http://www.keyence.com/plc/kvl.htm>
<http://www.autoware.com/english/demo.htm>
SW used in lab, Schneider/SoCollaborative Unity Pro, has simulator

Bibliography : Automatic Manufacturing Systems with PLCs, Hugh Jack
(online version available)
Programming Logic Controllers, Frank D. Petruzella
...

Standards: <http://www.plcopen.org/>

Types of PLCs

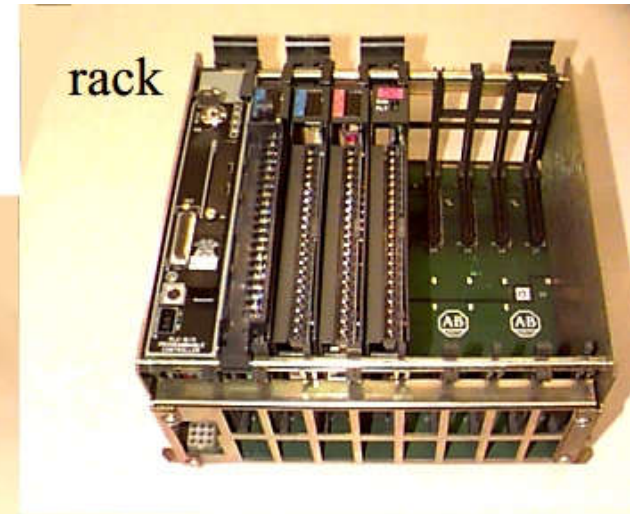

↑ may use **DIN rail 35mm** →
(the most common rail of
main electrical panels)

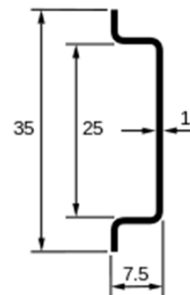

Phases of a Project in EE&CS:
(Automation included)

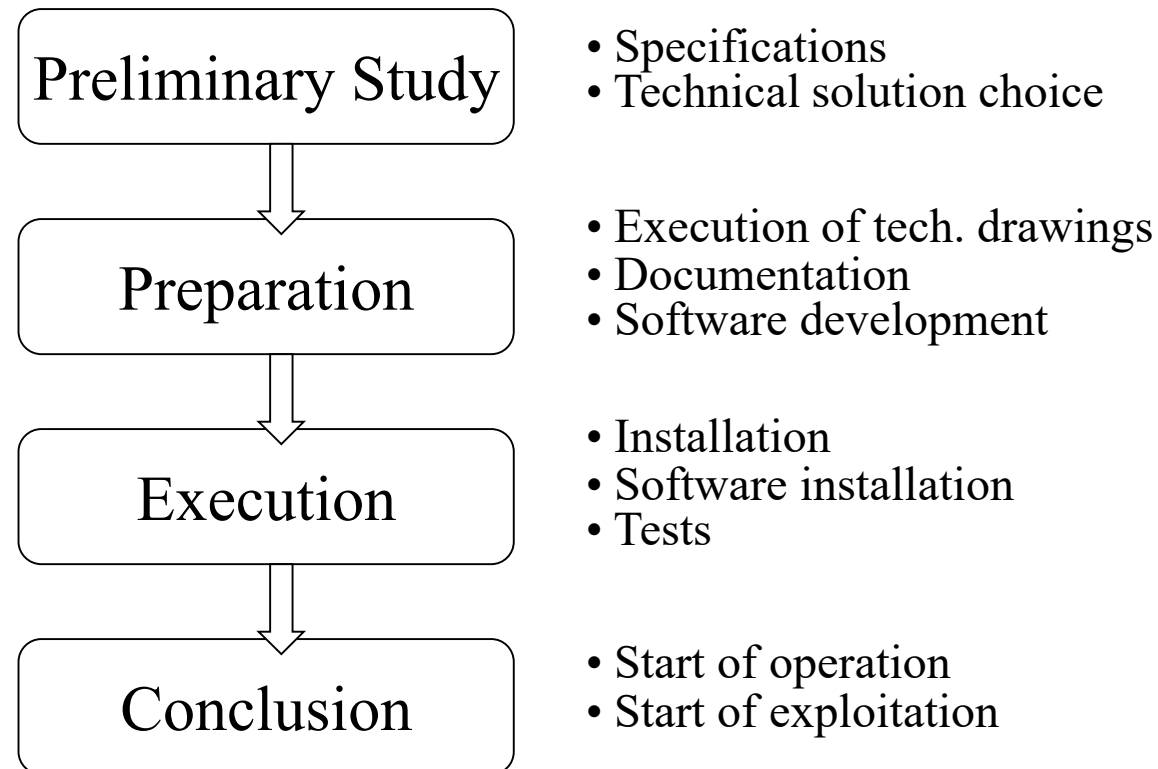

An Automation Example Solution based on PLCs

Example:

Automation of the Main Entrance Door, in “*PLCs Theory*,” [Omron]

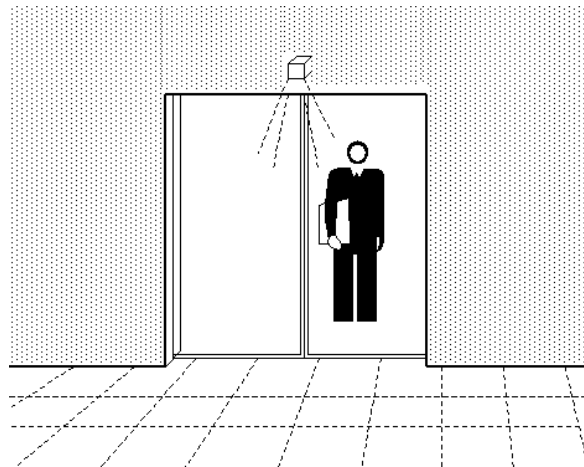

Example:

Automation of the Main Entrance Door, in “*PLCs Theory,*” [Omron]

Functional Specifications

An automatic system that could command the opening and close of a door is the main purpose of these specifications.

*The command operation will be **automatic** and **manual**. There must be a selector with two positions in a front panel of command to select the mode of operation.*

*The **manual** mode resorts to the use of two push buttons to open and close the door. Once the OPEN push button is pressed, **the door will be opened until the operation is completed, as detected by a limit switch**. Upon pushing the CLOSE button **the door will be commanded to close, until the end of the operation is detected by another limit switch**.*

*The **automatic** mode of operation resorts to the use of two sensors, that detect the proximity of the users. When a **person is detected** the automatic **opening of the door starts**. The door remains open for a period from 5 to 20 seconds, following the **null detection of the user**. After that period the door starts to close. If during this last phase the presence of **another user is detected** the **close operation is aborted** and a new cycle of opening starts.*

Example:

Automation of the Main Entrance Door, in “*PLCs Theory,*” [Omron]

Technological Specifications

*The **proximity sensor** that detects the users must be of a model that can be installed over the door (one in the interior and other in the exterior), and must be based on the reflection of infrared radiations, with output by transistor. The sensor sensitivity must be tuned such that its output becomes active if an user is at 2 meters of distance or less.*

*The **motor** that activates the open and close of the door must be electrical , three-phase, ..., etc.*

Operating Specifications

*A key must be required to be used in the model of the **automatic-manual selector**. A counter of the **number of operations** should be incorporated in the solution, to identify when maintenance is required. The maintenance must be at each 10000 operations, ... etc*

Example:

Automation of the Main Entrance Door, in “*PLCs Theory,*” [Omron]

Hardware list

Input (sensors):

- *Selector manual / automatic*
- *Push button open door*
- *Push button close door*
- *Proximity sensors*
- *Limit switch fully open*
- *Limit switch fully closed*

Output (actuators):

- *Motor actuation to open door*
- *Motor actuation to close door*

Combining all

- *Connect input and output hardware*
- *Implement functional and operational specifications, according to the technological specifications*

Automation Problems - PLC based solutions

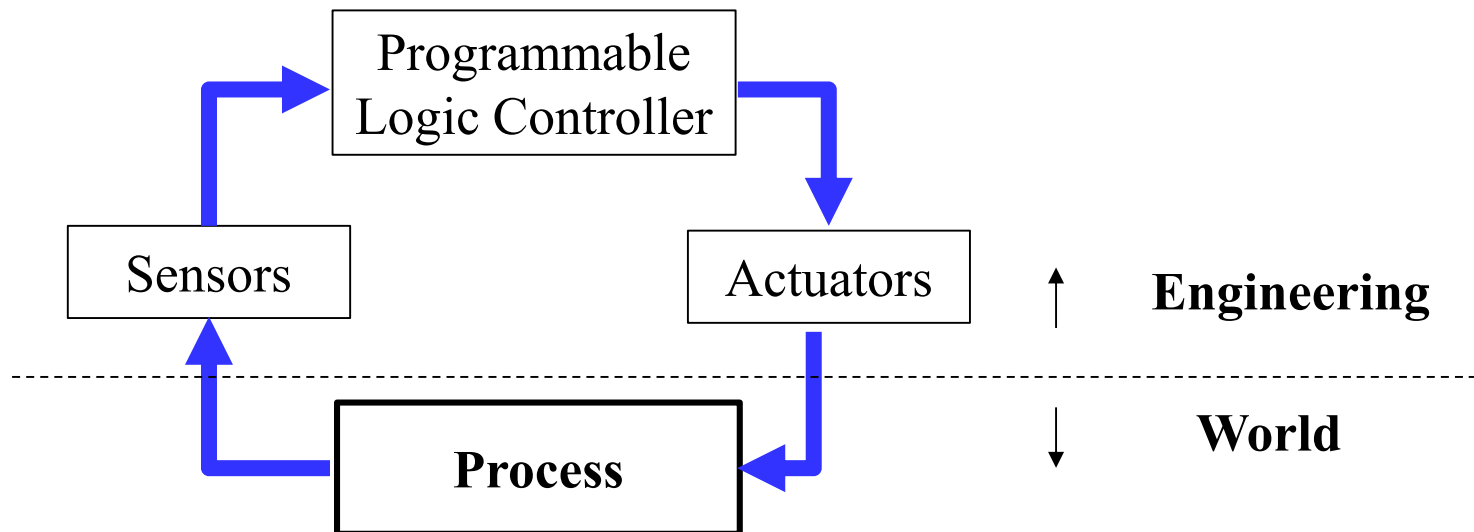

Using PLCs implies **connecting input** devices (for detection and sensing) and **output** devices (for command and control).

Using PLCs implies **developing software programs** for the PLCs to implement the proposed solution. Graphical user interfaces make trivial making simple (typical) PLC programs.

Architecture of PLCs

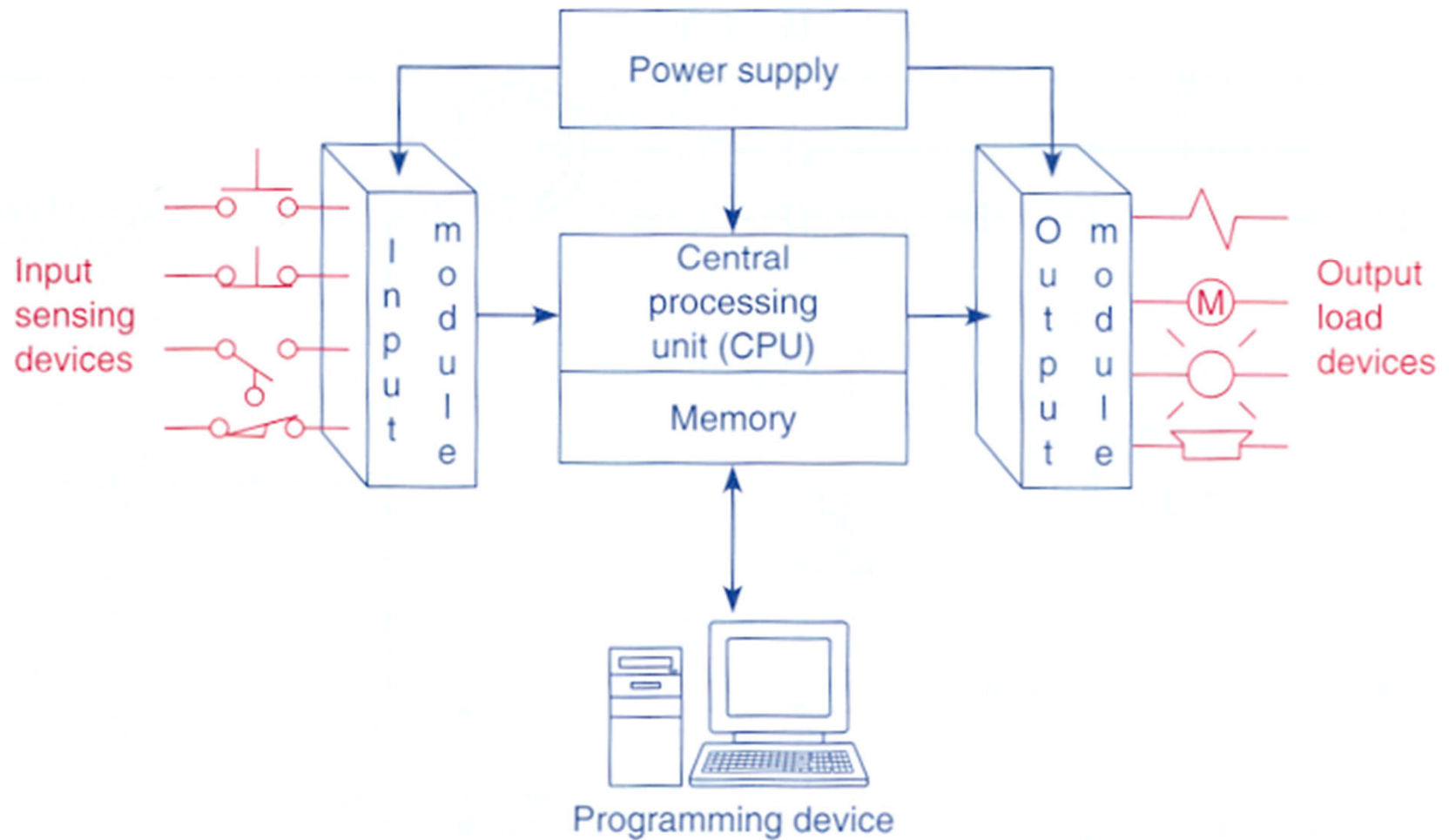

Architecture of PLCs

... and internally, how is it implemented?

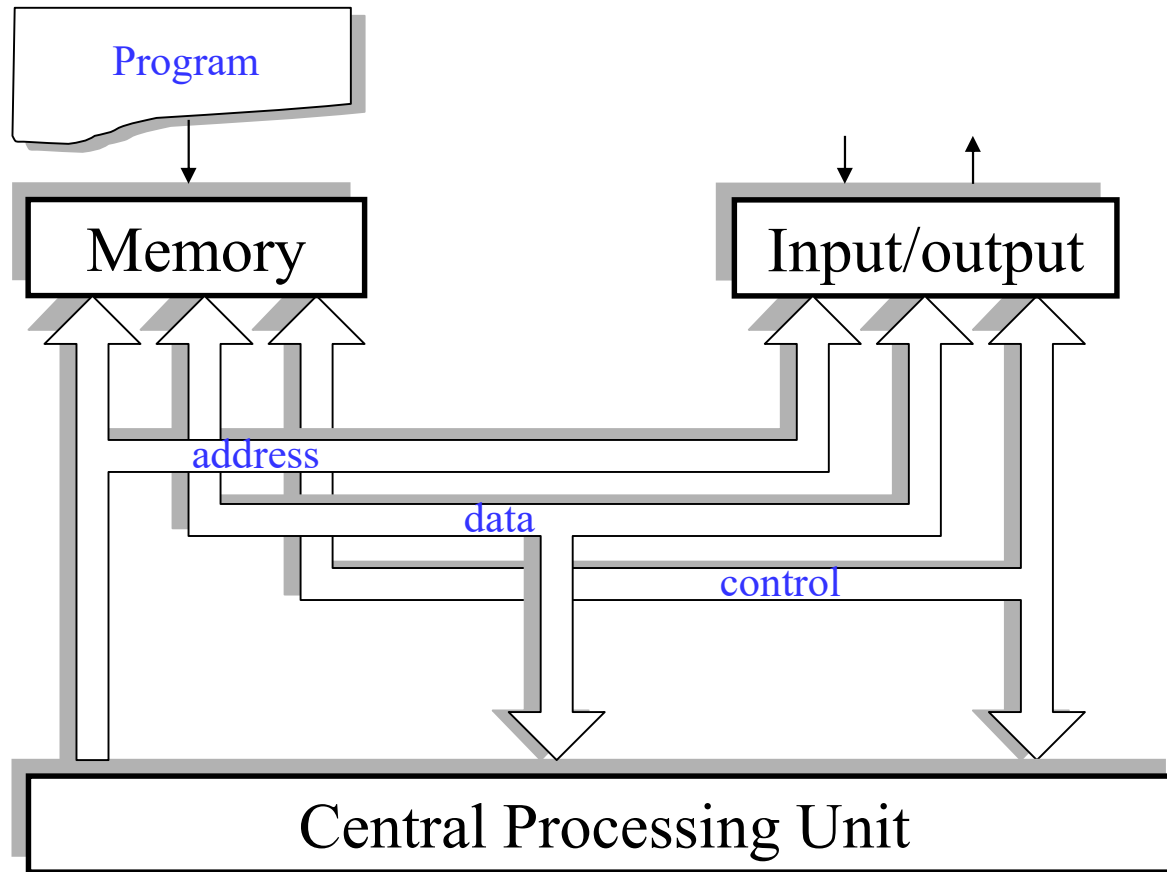

Architecture of PLCs vs PCs

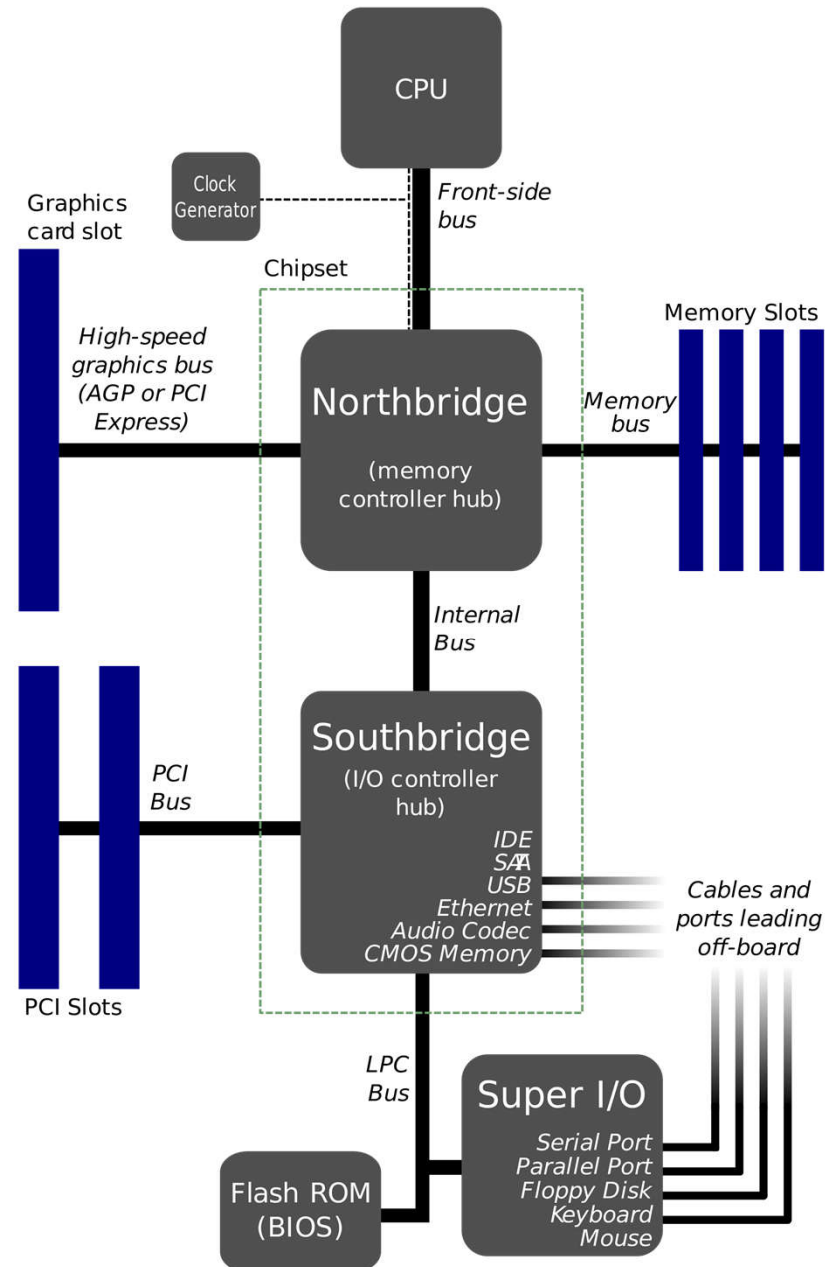
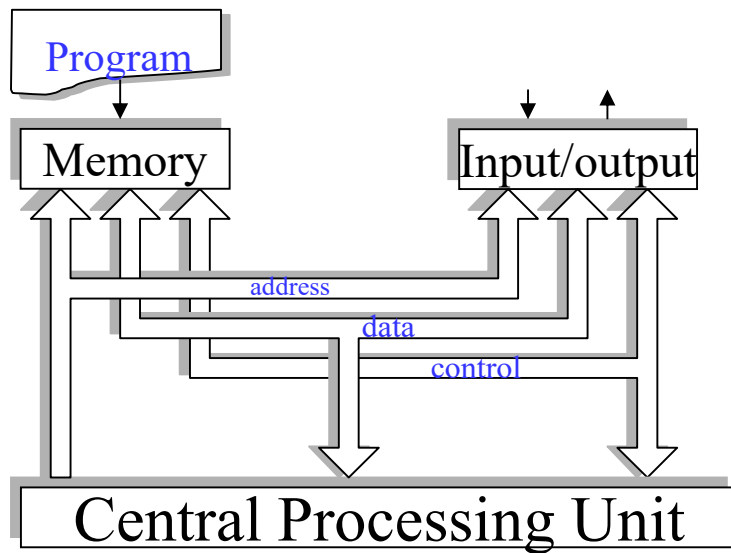

Architecture of PLCs

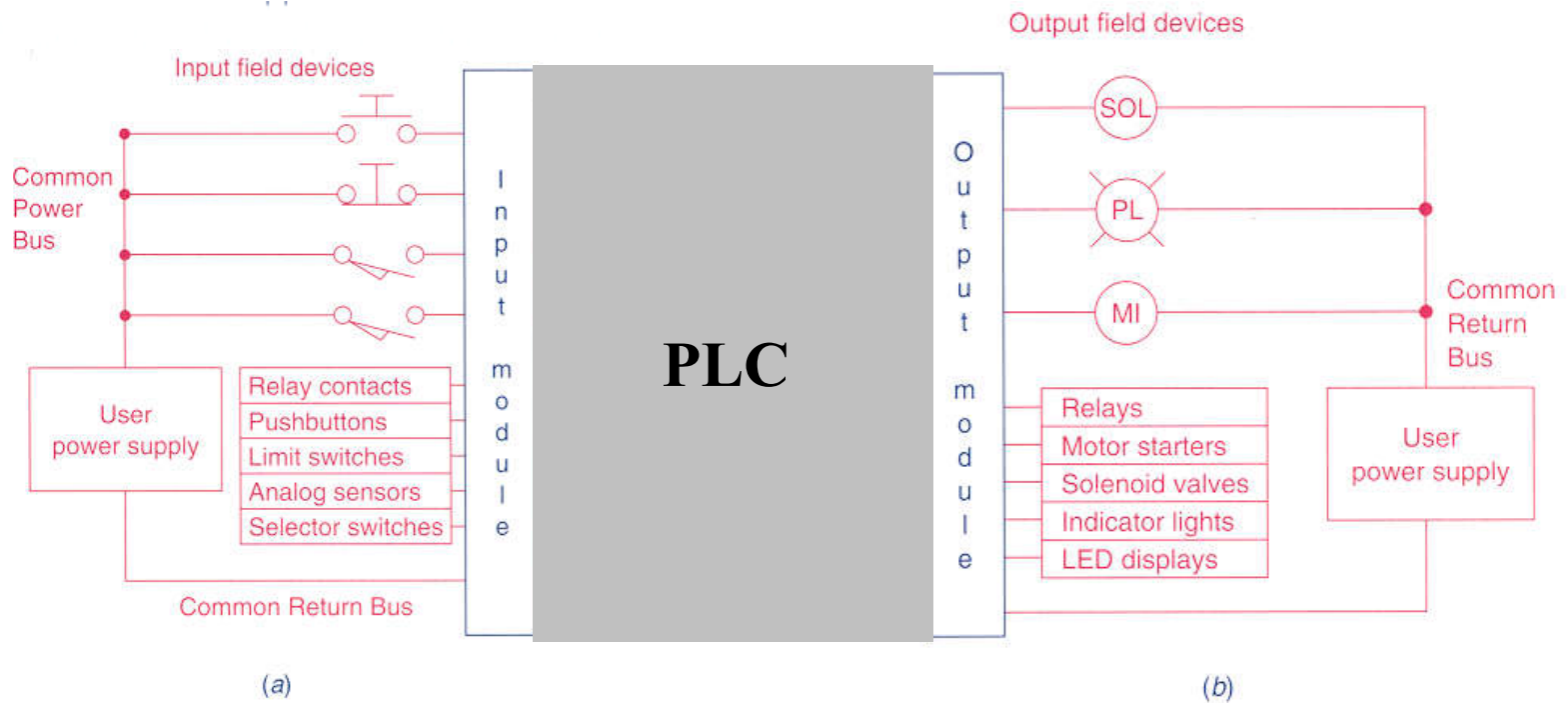
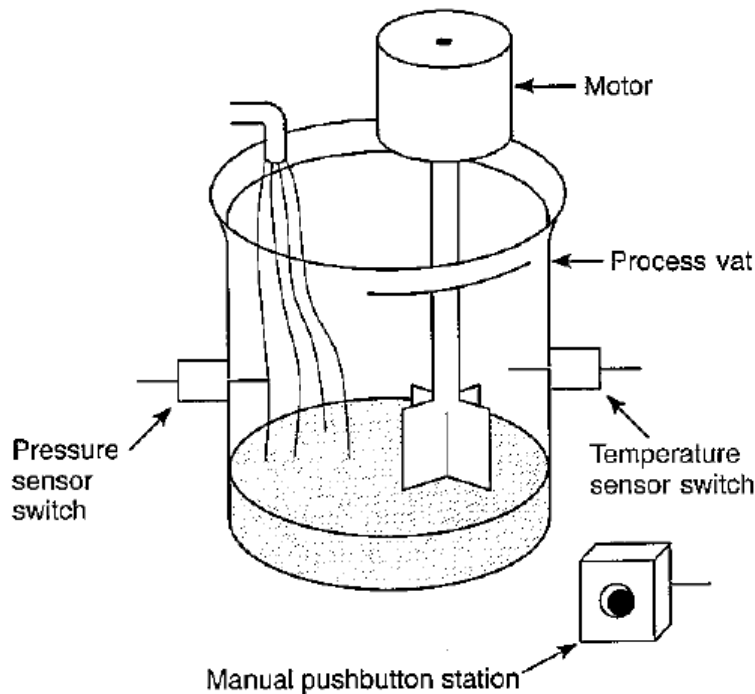

Fig. 1-6

(a) Typical input module. (b) Typical output module.

Example: Mixer Motor

Problem [Petruzella96]: A **mixer motor** is to be used to automatically stir the liquid in a vat when the **temperature and pressure** reach preset values. In addition, direct **manual** operation of the motor is provided by means of a separate pushbutton station.



Solution using the relay diagram:

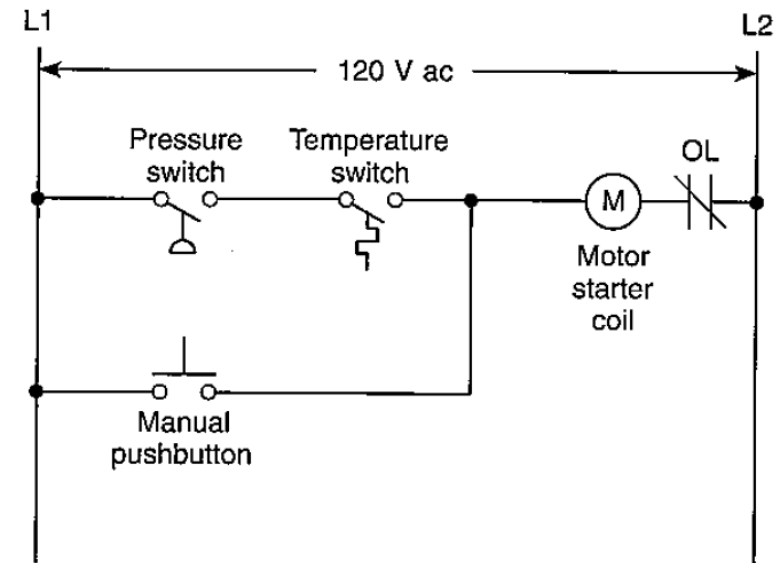

Example: Mixer Motor, input

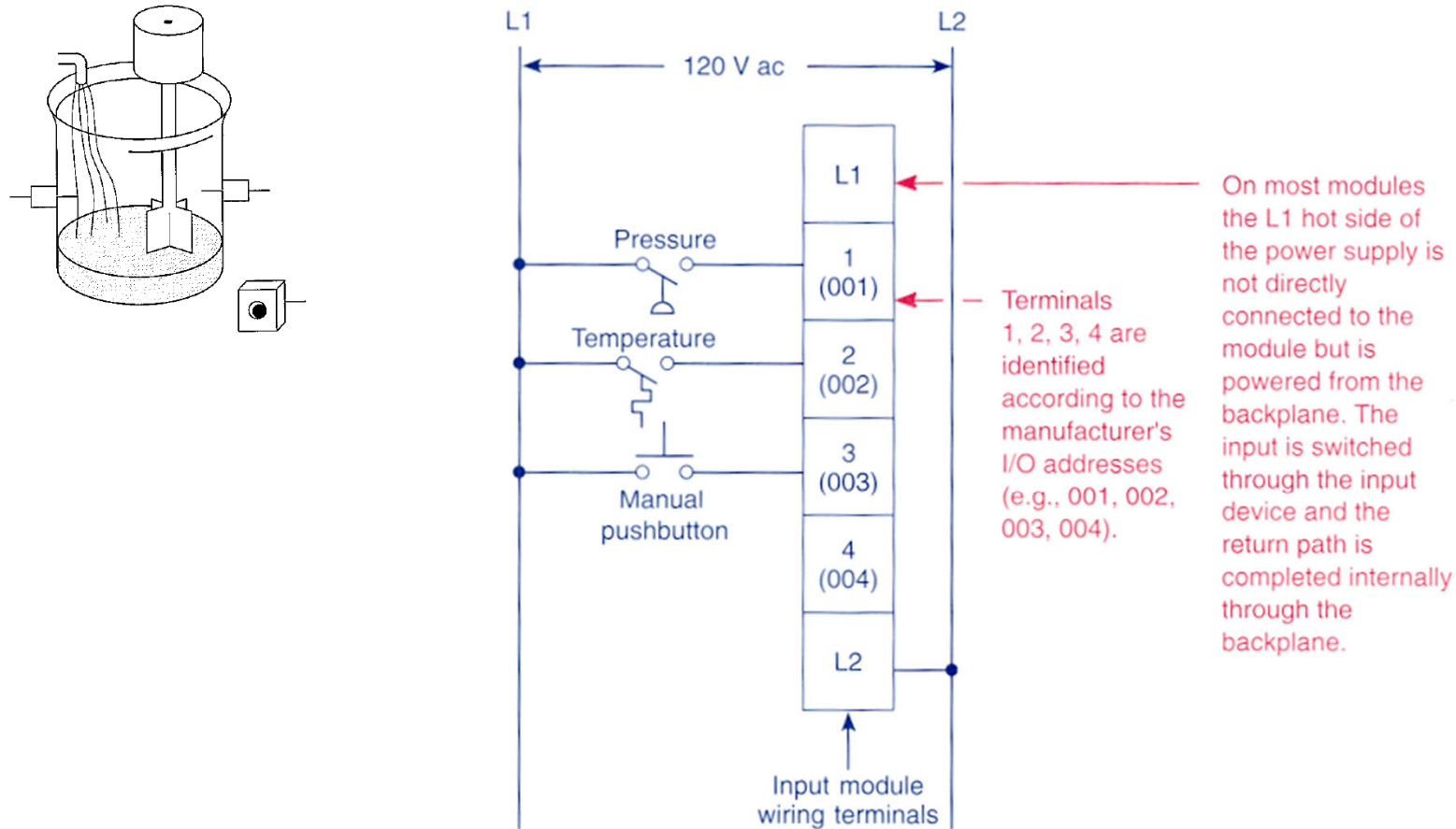

Fig. 1-10

Typical input module wiring connections.

Example: Mixer Motor, output

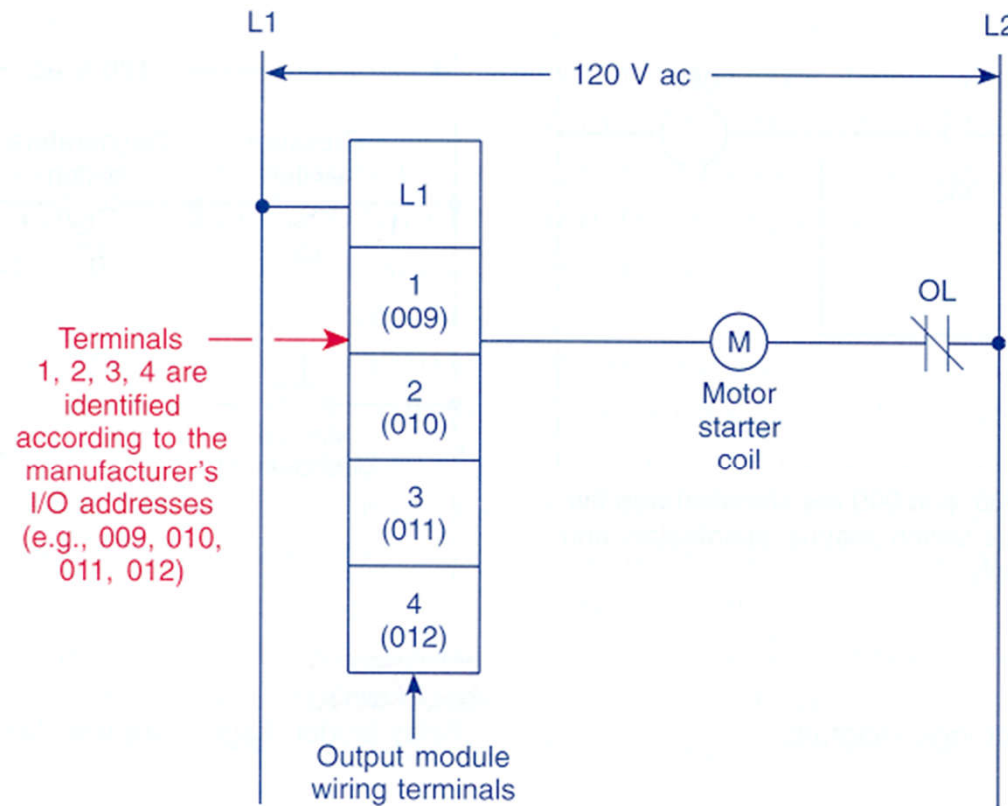
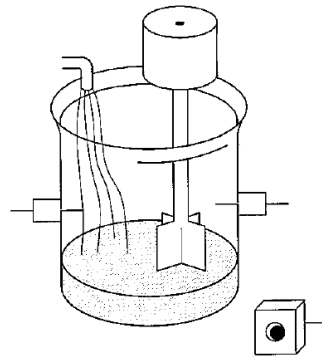
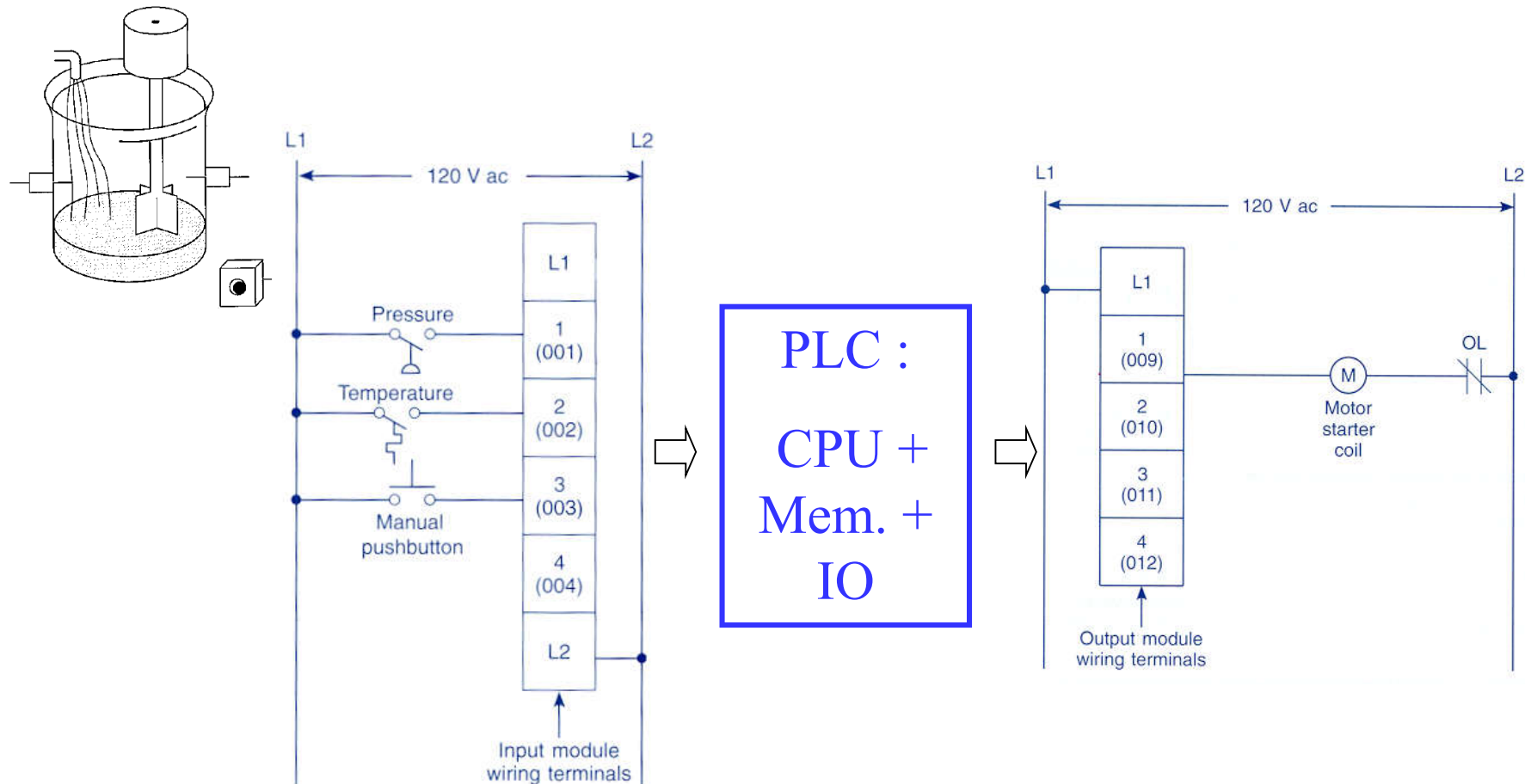

Fig. 1-11

Typical output module wiring connections.

Example: Mixer Motor, input + CPU/Memory + output



Internal structure and Work principles

Example: Motor Start / Stop

Command of a motor from a console with start and stop buttons.

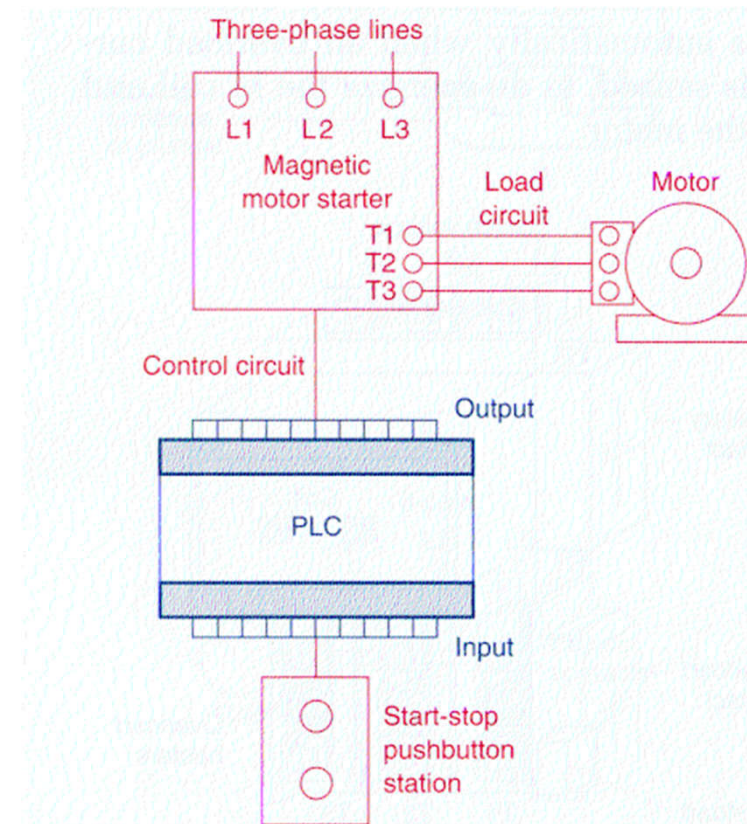

Fig. 6-9

When a PLC needs to control a large motor, it must work in conjunction with a starter.

Internal structure and Work principles

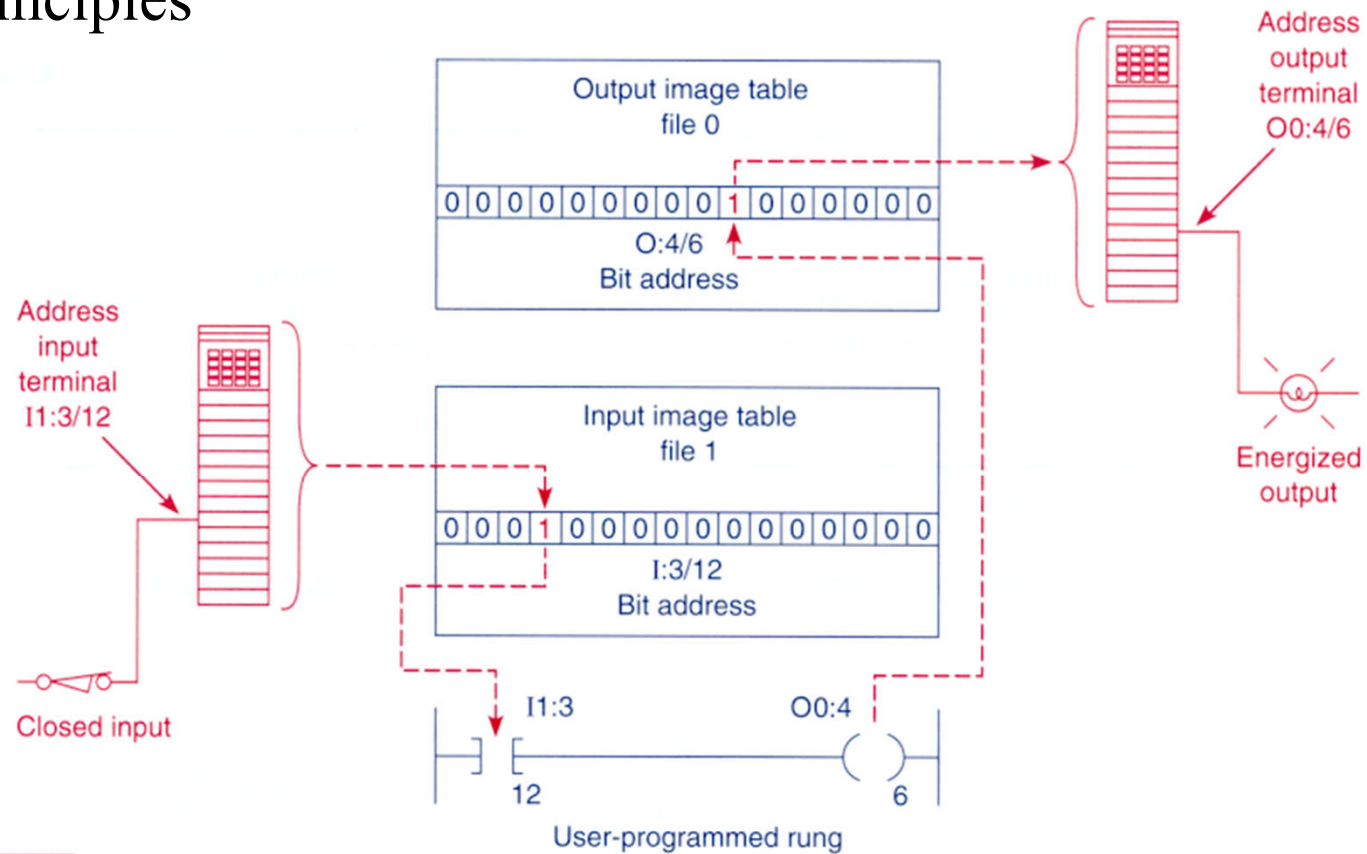
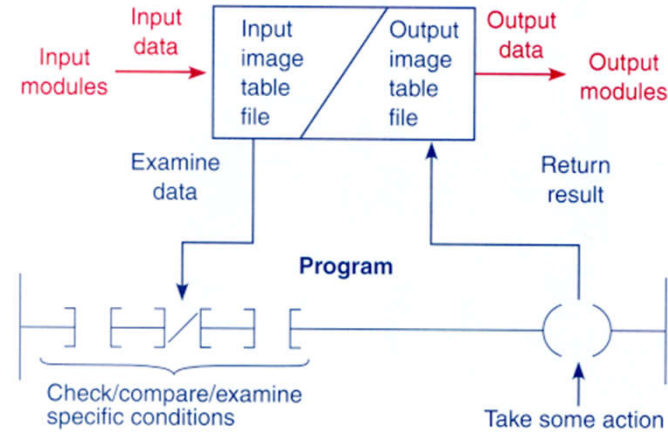

Fig. 5-17

The address identifies a location in the processor's data files, where the on/off state of the bit is stored.

Internal structure and Work principles



(a) Data flow overview

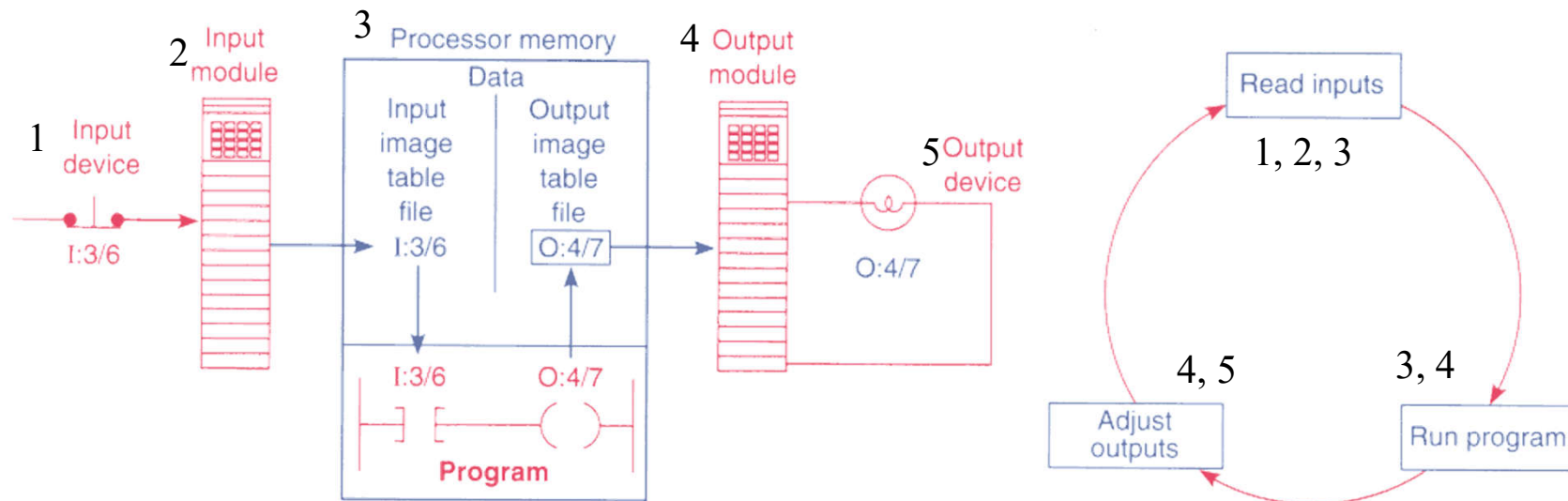

(b) Scan cycle

Fig. 5-7

Scan process.

Internal structure and work principles



8.2.1 The Input and Output Scans

When the inputs to the PLC are scanned the **physical input values are copied into memory**. When the outputs to a PLC are scanned they are copied **from memory to the physical outputs**. When the ladder logic is scanned it uses the values in memory, not the actual input or output values. The primary reason for doing this is so that if a program uses an input value in multiple places, a change in the input value **will not invalidate the logic**. Also, if output bits were changed as each bit was changed, instead of all at once at the end of the scan the PLC would operate much slower.

[From Hugh Jack (PLCs book)]

Internal structure and work principles

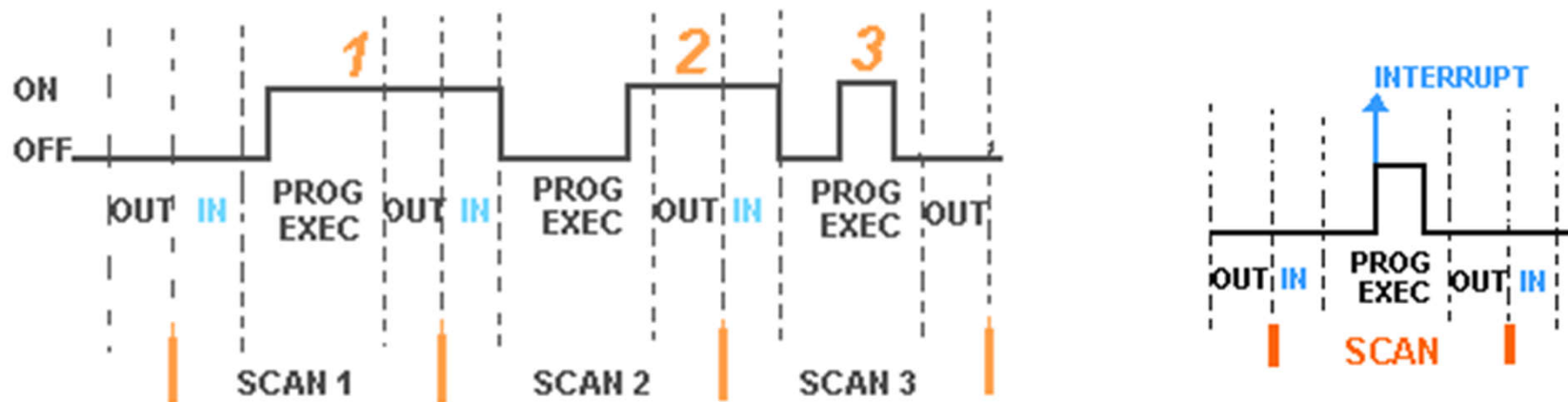

Scan / Scan Cycle (input / prog exec / output), **Scan Period** (time T)

The **inputs** must be active for at least one scan cycle to have impact (no uncertainty) in the **internal PLC** state and indirectly in the outputs.

Exception: interrupts...

Internal structure and work principles

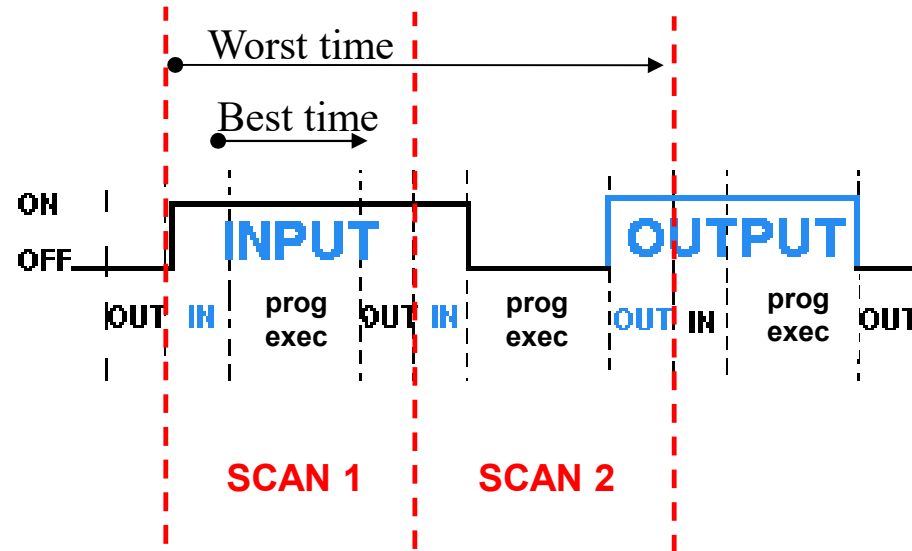

Q: Worst time interval for an input to have impact on an output (with probability one)?

A: 2x Scan Period

Q: Smallest time interval (with probability greater than zero) that the change in one input can impact in one output?

A: Scan Period – Read Time – Write Time = Execution Time

Internal structure and work principles

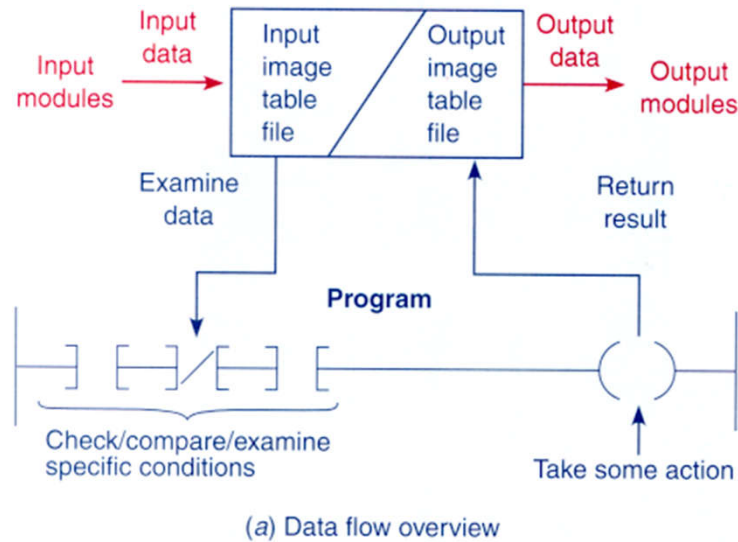

Interface for inputs and outputs

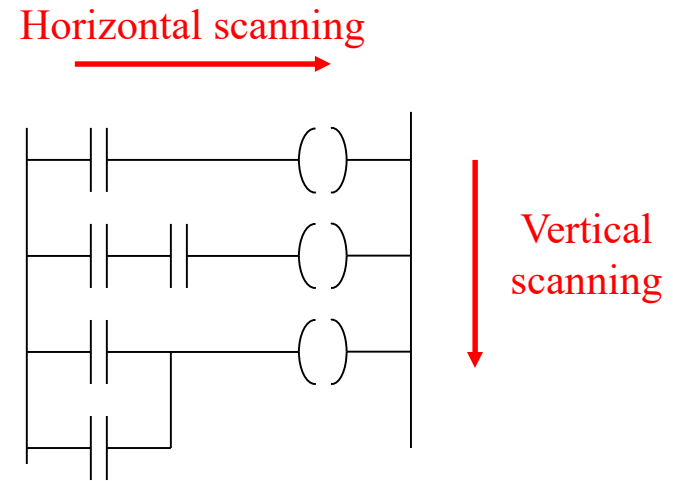

Scanning rungs...

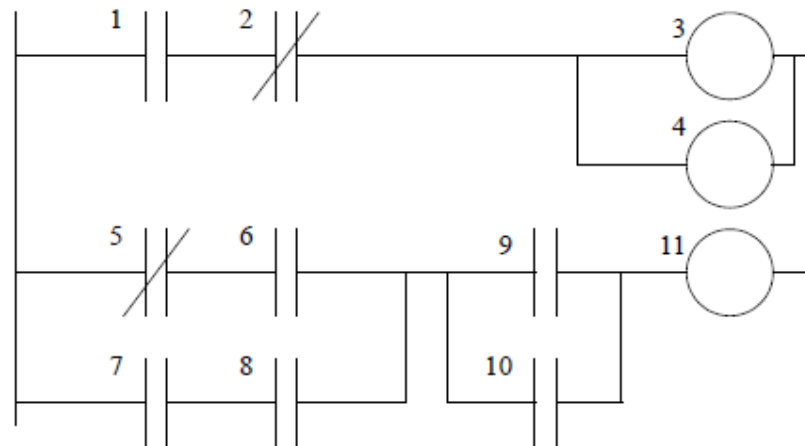

Figure 8.4
Ladder Logic Execution Sequence

8.2.2 The Logic Scan

Ladder logic programs are modeled after relay logic. In relay logic each element in the ladder will switch as quickly as possible. But in a program **elements can only be examined one at a time in a fixed sequence**. Consider the ladder logic in Figure 8.4, the ladder logic will be **interpreted left-to-right, top-to-bottom**. In the figure the ladder logic scan begins at the top rung. At the end of the rung it interprets the top output first, then the output branched below it. On the **second rung it solves branches**, before moving along the ladder logic rung.

[From Hugh Jack (PLCs book)]

Components of Programmable Logic Controllers

1. Programming (using specific devices or PCs)

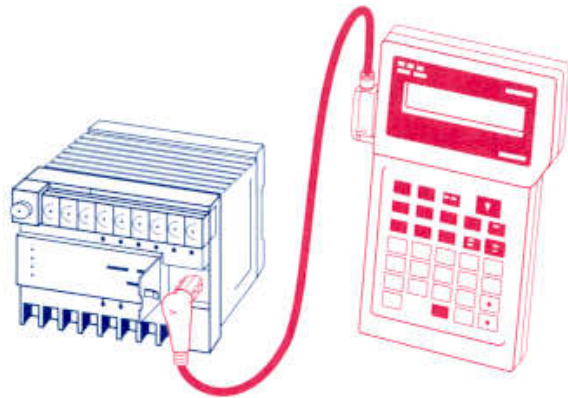

Honeywell console



Omron console

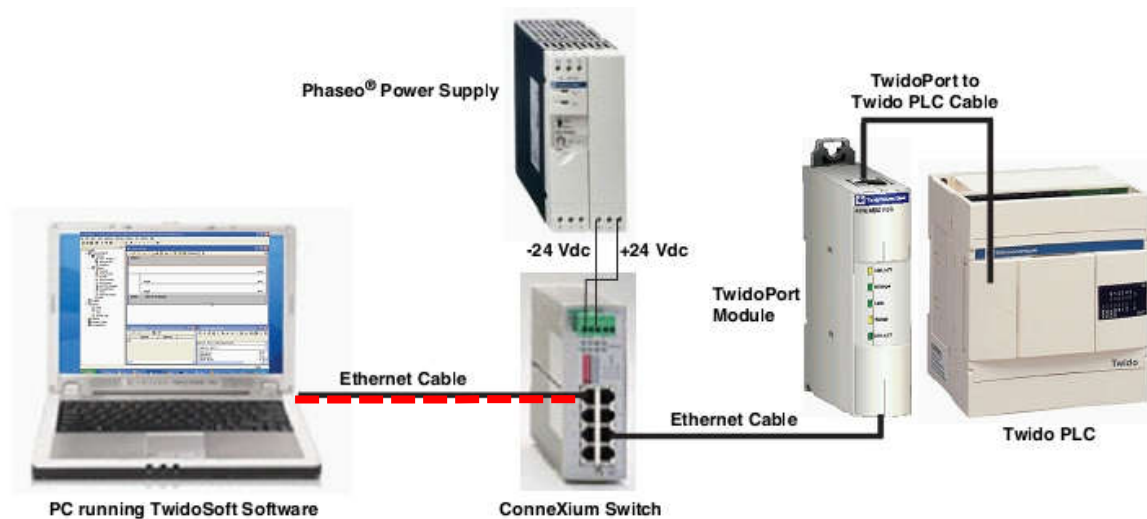
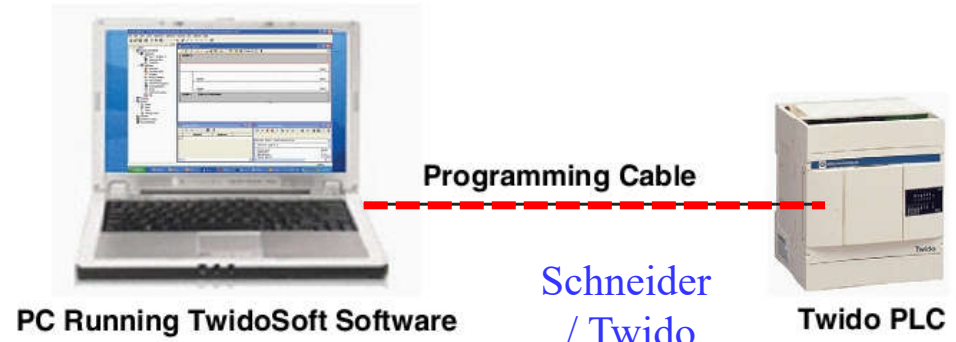

Ethernet is now common

Components of PLCs: Input and output interfaces

2.1 AC input module (discrete)

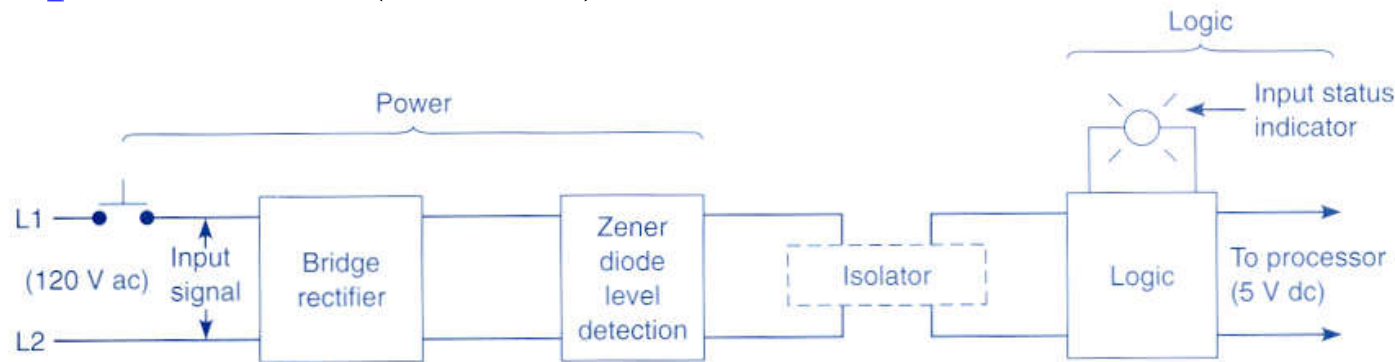

Block diagrams of a discrete input module.

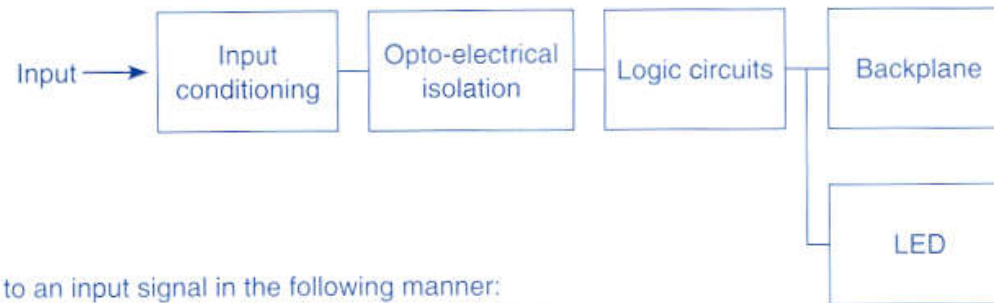

- The input circuit responds to an input signal in the following manner:
- An input filter removes false signals due to contact bounce or electrical interference
 - Opto-electrical isolation protects the input circuit and backplane circuits by isolating logic circuits from input signals
 - Logic circuits process the signal
 - An input LED turns ON or OFF, indicating the status of the corresponding input device

Fig. 2-6

AC discrete input module.

Components of PLCs: Input and output interfaces

2.1 AC input module: simplified implementation

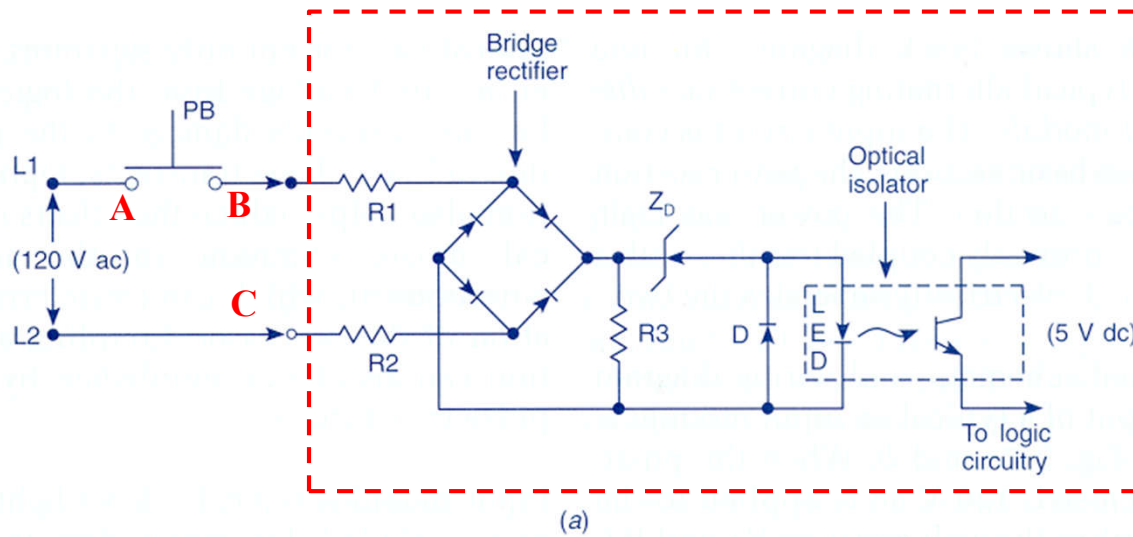

Electronic circuit

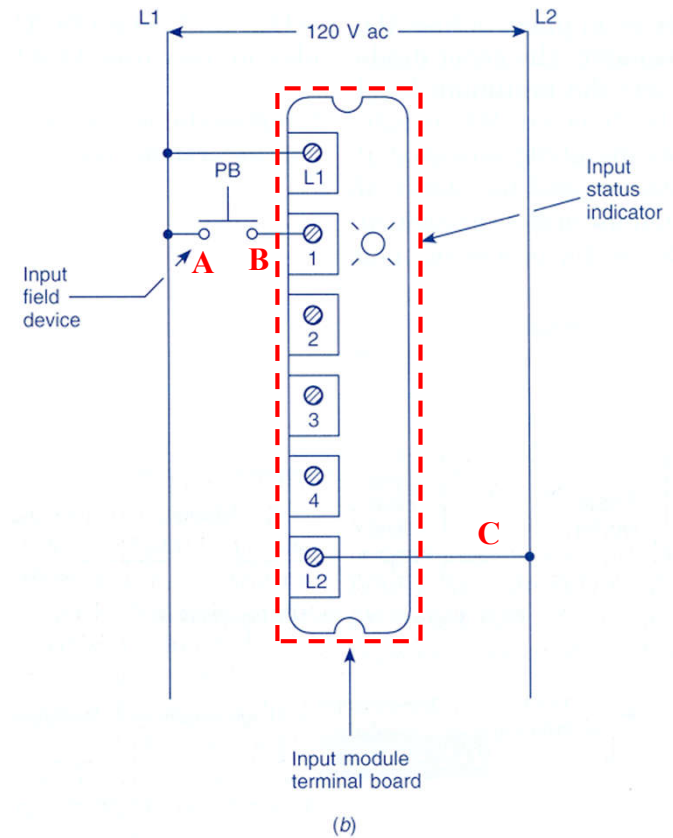

Connections to the PLC terminals

Components of PLCs: Input and output interfaces

2.2 AC output module (discrete)

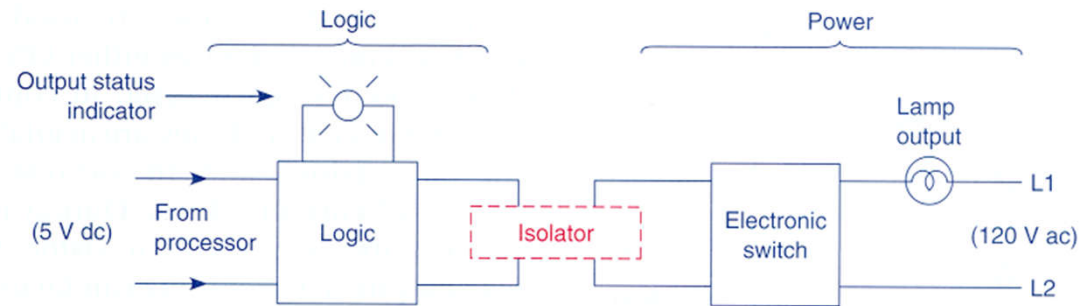

(a) Block diagram of a discrete output module.

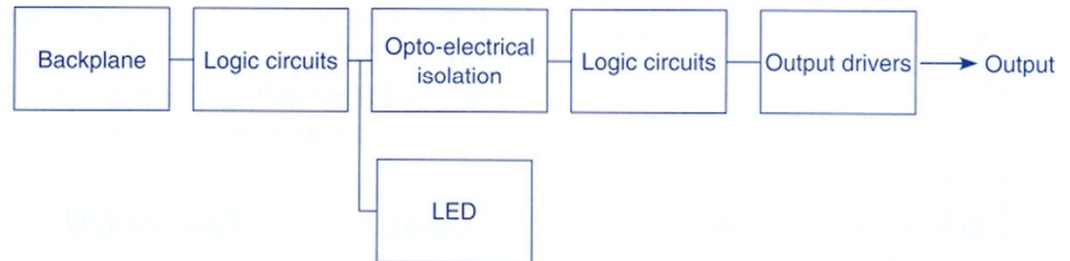

(b) The output circuit controls the output signal in the following manner:

- Logic circuits determine the output status
- An output LED indicates the status of the output signal
- Opto-electrical isolation separates output circuit logic and backplane circuits from field signals
- The output driver turns the corresponding output ON or OFF.

Fig. 2-8

AC discrete output module.

Components of PLCs: Input and output interfaces

2.2 AC output module (discrete)

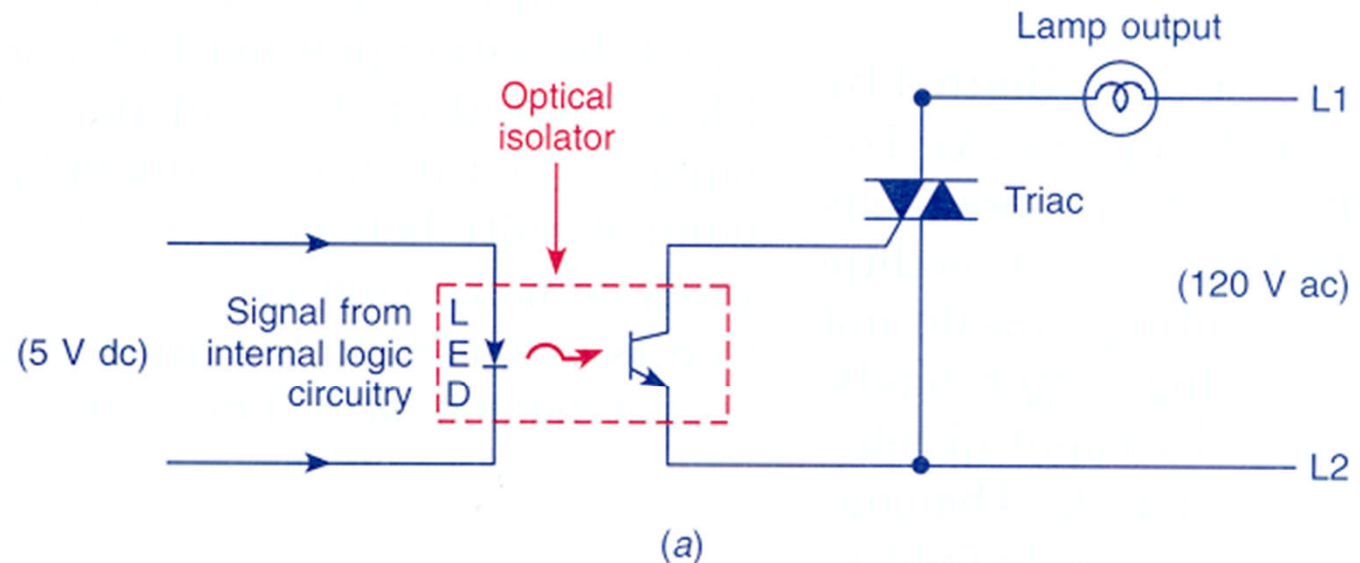

Fig. 2-9

(a) Simplified schematic for an ac output module.

Components of PLCs: Input and output interfaces

2.3 DC input module (discrete)

Attention to:

- Galvanic isolation
- Economy
- Consumption
- Switching speed
- Noise immunity

Relay

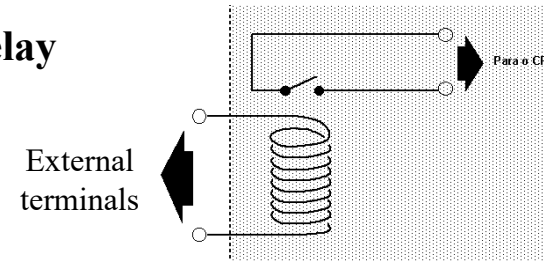

Transistor

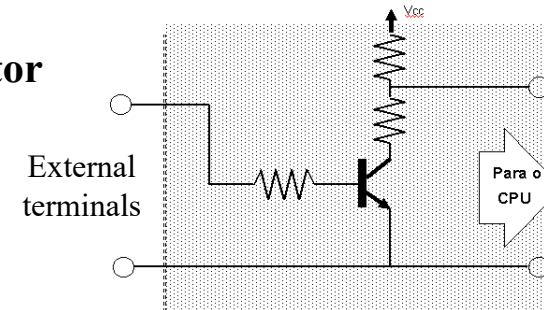

Opto-coupler

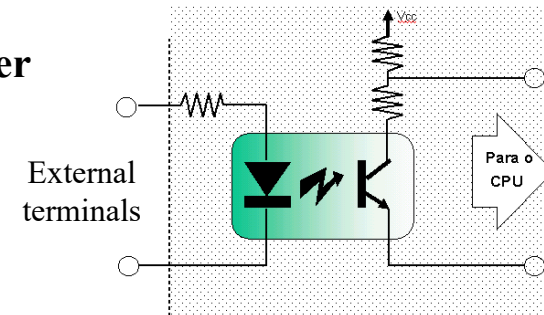

CPU

Components of PLCs: Input and output interfaces

2.4 DC output module (discrete)

CPU

Relay

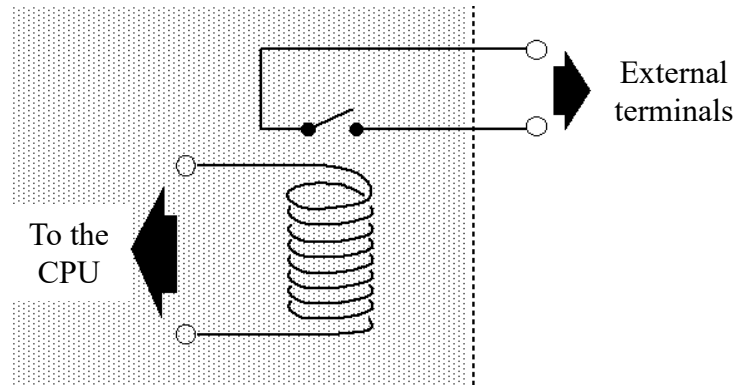

Transistor

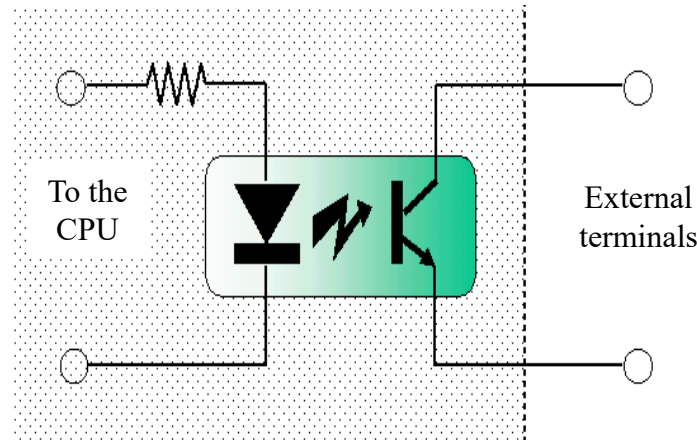

Connections to terminals ...

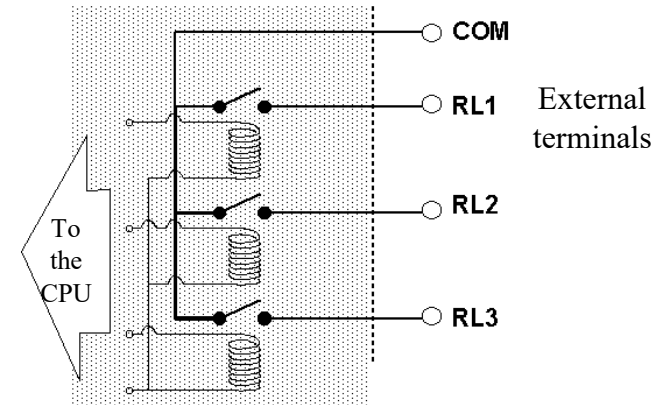

... and protections.

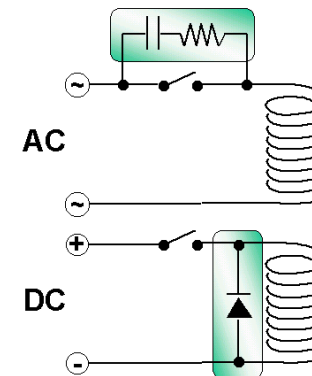

Components of Programmable Logic Controllers

3. Power sources

Attention to:

- Isolation to the noise
- Isolation relative to disturbances on the network
- Efficiency
- Consumption
- Size (volume and weight)
- Robustness relative to load variations

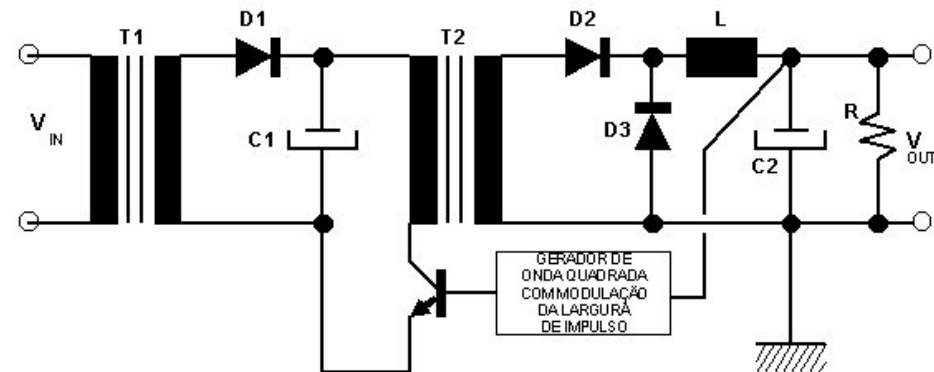

Switching power sources

Types of PLCs

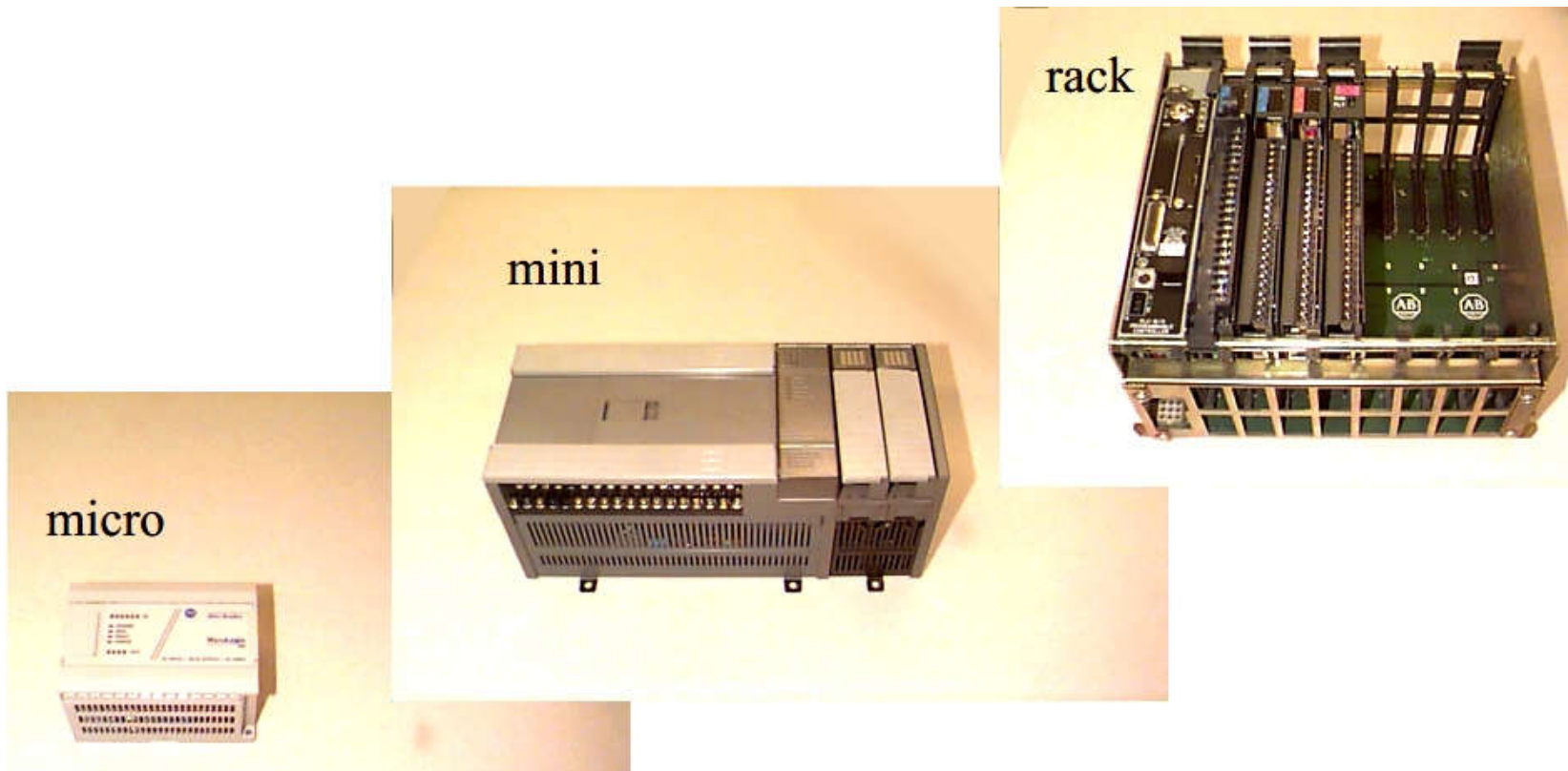

Rockwell Automation / Allen-Bradley

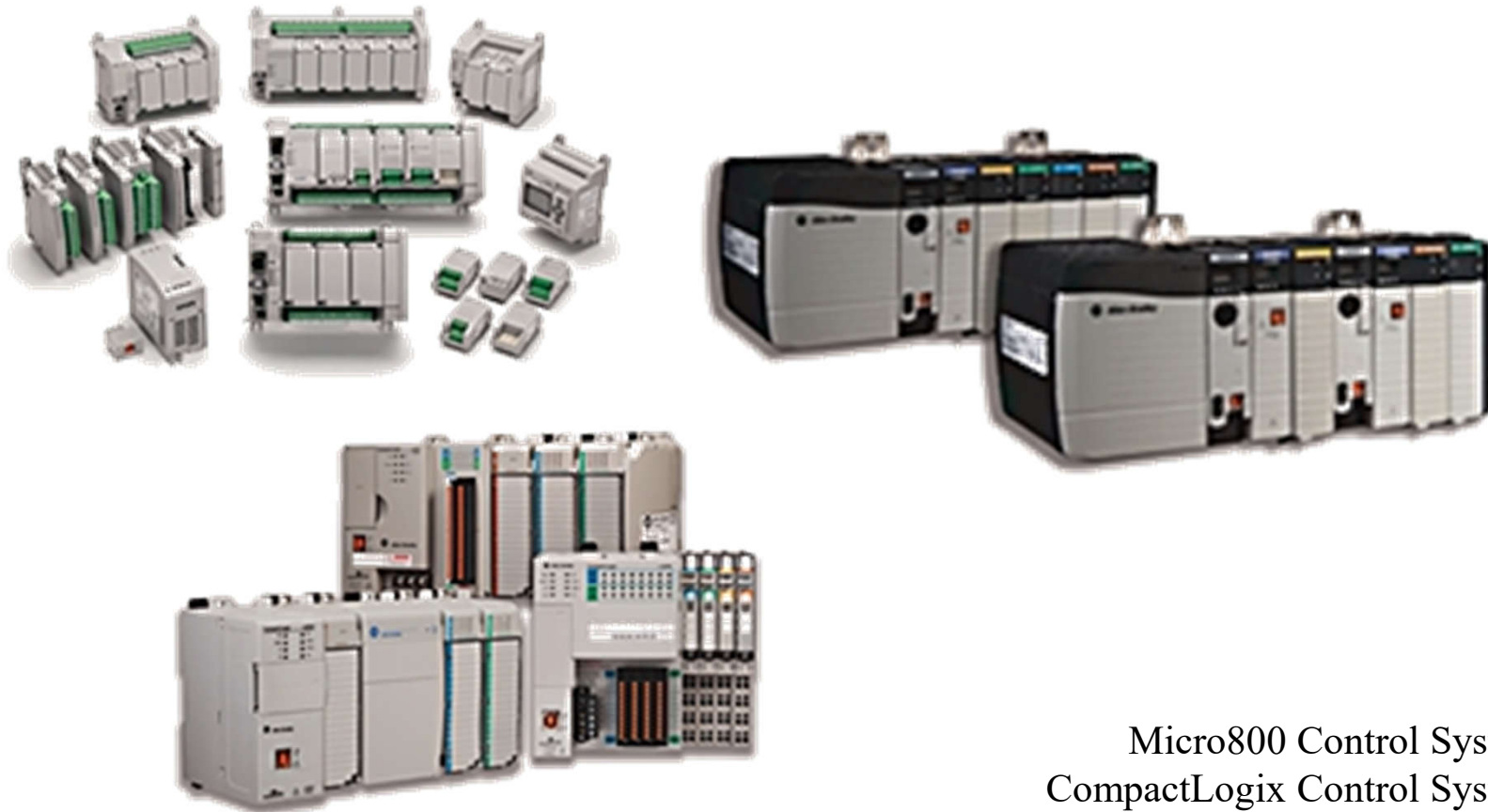

Micro800 Control Systems
CompactLogix Control Systems

<http://ab.rockwellautomation.com/Programmable-Controllers>

Siemens SIMATIC S7



Modular controllers:
SIMATIC S7-1200
SIMATIC S7-1500
SIMATIC S7-200
SIMATIC S7-300
SIMATIC S7-400

<http://www.automation.siemens.com>

Schneider / Modicon

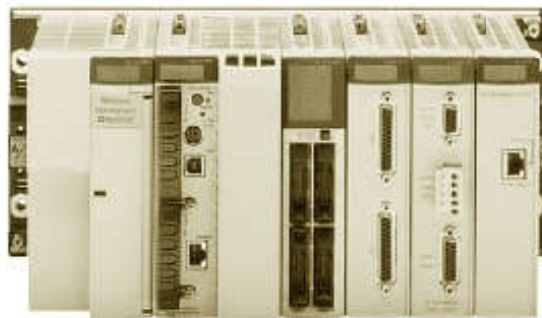

Twido
Modicon Premium
Modicon Quantum
<http://www.schneider-electric.com>

The top most used PLC systems around the world

From <http://www.control.com/thread/948918117>

Vijay Bharadva, 16Sept2009

Depends on the application:

1. Process industry : Rockwell
2. Machine application : Rockwell/Siemens
3. CNC application : Siemens/Allen-Bradley
4. Power industry : GE Fanuc
5. Tyre Industry : Rockwell/Modicon
6. Building automation : Telemecanique/Siemens LOGO/Rockwell PICO.

Johan Bengtsson 7March2000

most popular PLC:s: A-B, Siemens and Schneider Electric. Modicon, Mitsubishi and Omron being a little bit smaller but quite significant.

North America: mostly Allen-Bradley

Europe: mostly Siemens

Asia: mostly Mitsubishi

Michael Sullivan 2February2000

PLCs market share:

-- Europe

1. Siemens
2. Schneider Electric
3. Rockwell

-- North America

1. Rockwell
2. Schneider Electric
3. Siemens

-- Worldwide

1. Siemens
2. Rockwell
3. Schneider Electric

Mitsubishi has the leading market share in Japan and many other Asian countries.

Schneider Electric, Rockwell, and Siemens also have a strong presence in Asia.