

Industrial Automation

(Automação de Processos Industriais)

DES and Industrial Automation

<http://users.isr.ist.utl.pt/~jag/courses/api1213/api1213.html>

Slides 2010/2011 Prof. Paulo Jorge Oliveira
Rev. 2011-2013 Prof. José Gaspar

Syllabus:

Chap. 7 – Analysis of Discrete Event Systems [2 weeks]

...

Chap. 8 - DESs and Industrial Automation [1 week]

GRAFCET / Petri Nets Relation

Model modification

Tools adaptation

Analysis of industrial automation solutions by analogy with
Discrete Event Systems

...

Chap. 9 – Supervision of DESs [1 week]

Some pointers to Discrete Event Systems

- History: <http://prosys.changwon.ac.kr/docs/petrinet/1.htm>
- Tutorial: <http://www.eit.uni-kl.de/litz/ENGLISH/members/frey/VnVSurvey.htm>
<http://vita.bu.edu/cgc/MIDEDS/>
<http://www.daimi.au.dk/PetriNets/>
- Analysers,
and
Simulators: <http://www.ppgia.pucpr.br/~maziero/petri/arp.html> (in Portuguese)
<http://wiki.daimi.au.dk:8000/cpntools/cpntools.wiki>
<http://www.informatik.hu-berlin.de/top/pnk/download.html>
- Bibliography: * **Petri Nets and GRAFCET: Tools for Modelling Discrete Event Systems**
R. DAVID, H. ALLA, New York : PRENTICE HALL Editions, 1992

DES Implementation: **Models**

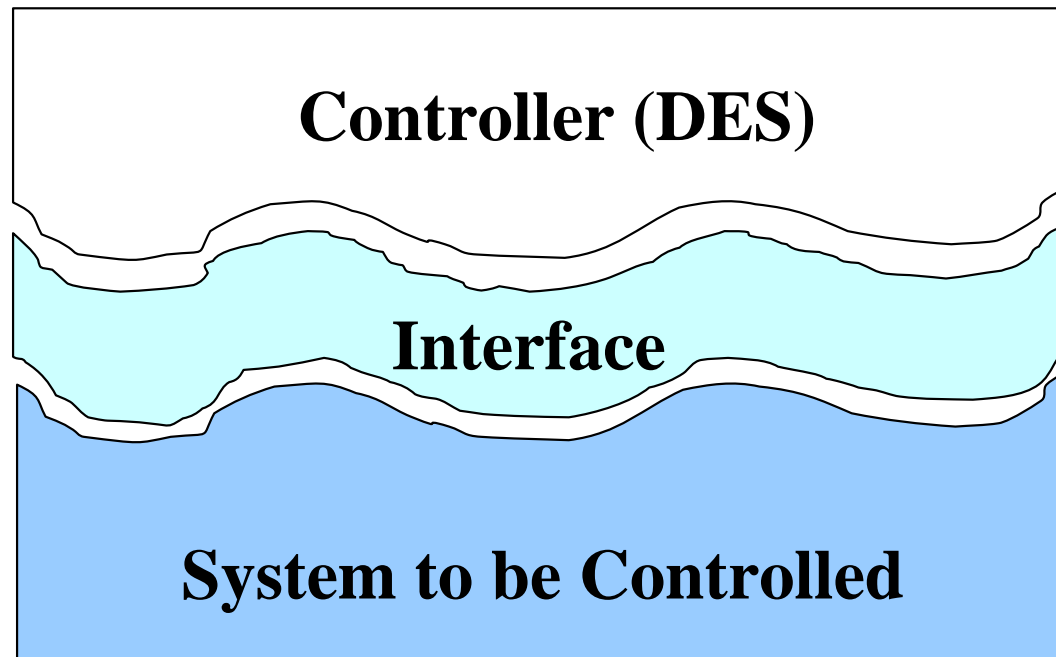

Besides modelling the **DES** it is required to design **models** of the **System to be controlled** and of the **Interface** to be used

Given a Discrete Event System how to implement it?

1. Use a GRAFCET

- a) Less modeling ability
- b) Implementation in PLCs is straightforward
- c) **No analysis (or very scarce) methods available**

2. Use a Petri Net

- a) More modeling capacity
- b) **No direct implementation in PLCs** (therefore indirect or special software solutions required)
- c) Classical analysis methods available

(3. Use an Automaton)

DES Implementation: Petri Net and HW

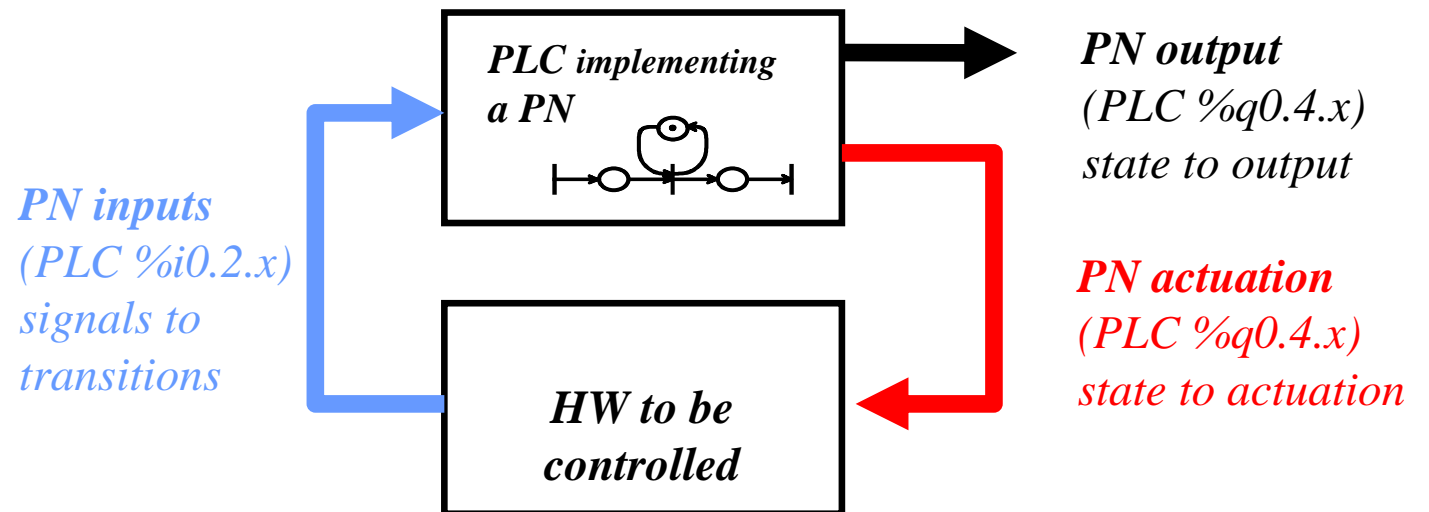
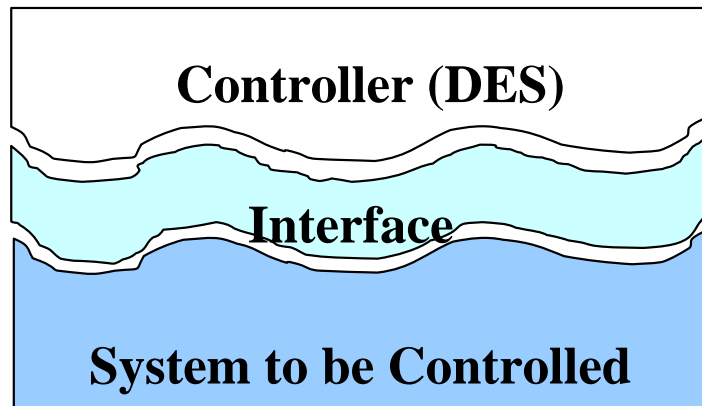

Analysis of solutions

GRAFCET and Petri Nets

Similarities to exploit:

- a) Steps and Places are similar
- b) Transitions compose both tools
- c) Places can be used to implement **counters** (on marking changes) and **binary variables** (marked vs unmarked place)
- d) **Logic** functions can be rewritten resorting to the firing of transitions

Differences to be taken into account:

- a) Firing rules (mutual exclusion)
- b) Conflicts
- c) **Binary** activation of stages
- d) Interface with the system to be controlled
- e) Activation functions

Implementation of DES using GRAFCET

Analysis

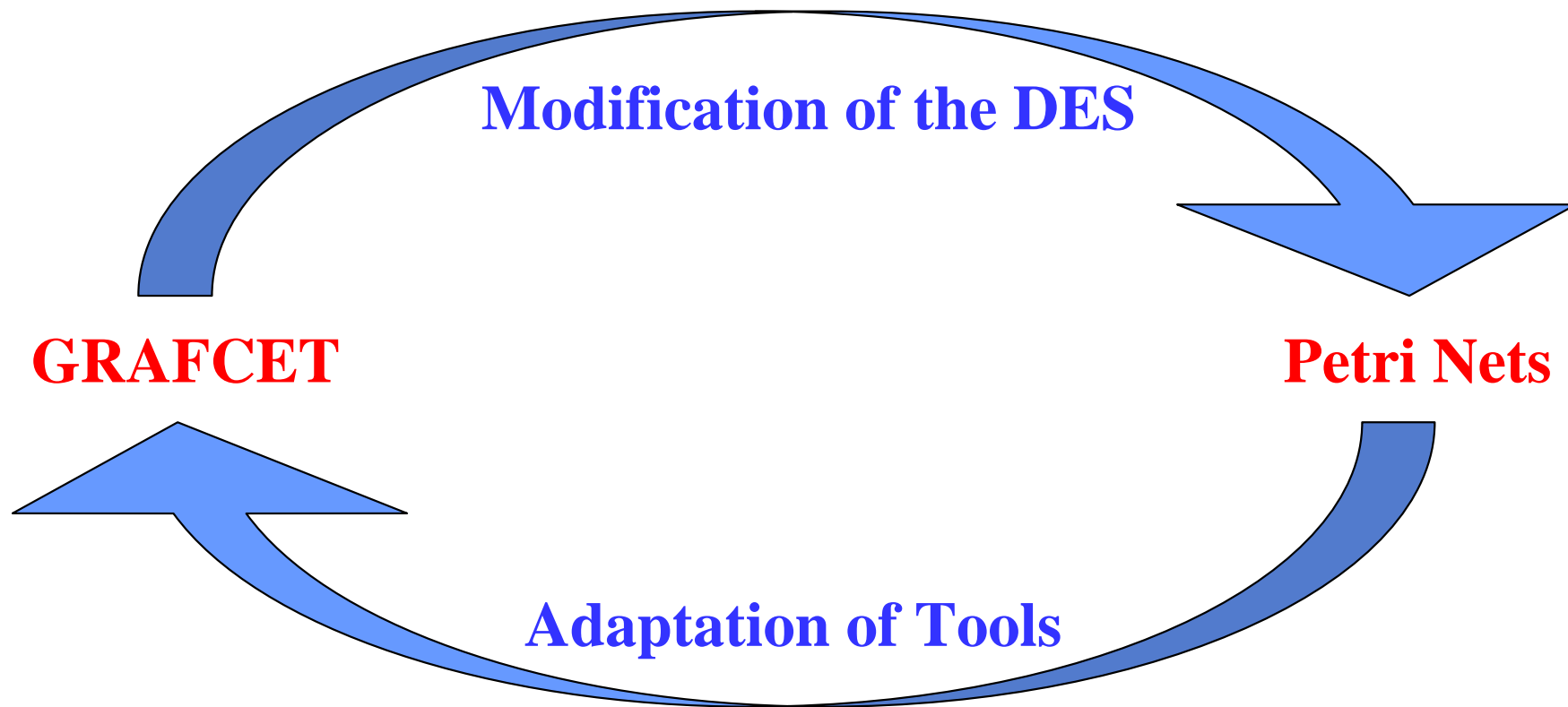

Implementation of DES using Petri Nets

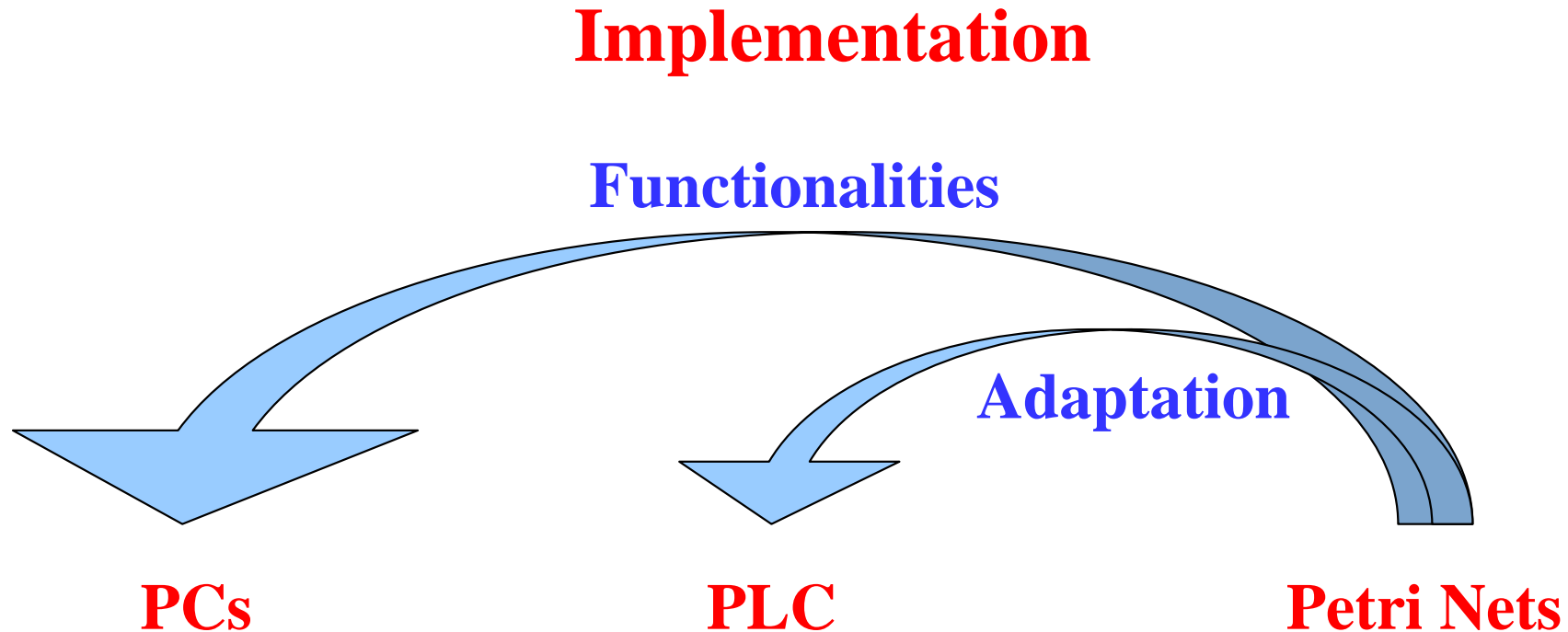

Both solutions are valid.
Out of the scope of this course.

Analysis of solutions

GRAFCET → Petri Nets

Representation of variables active on level

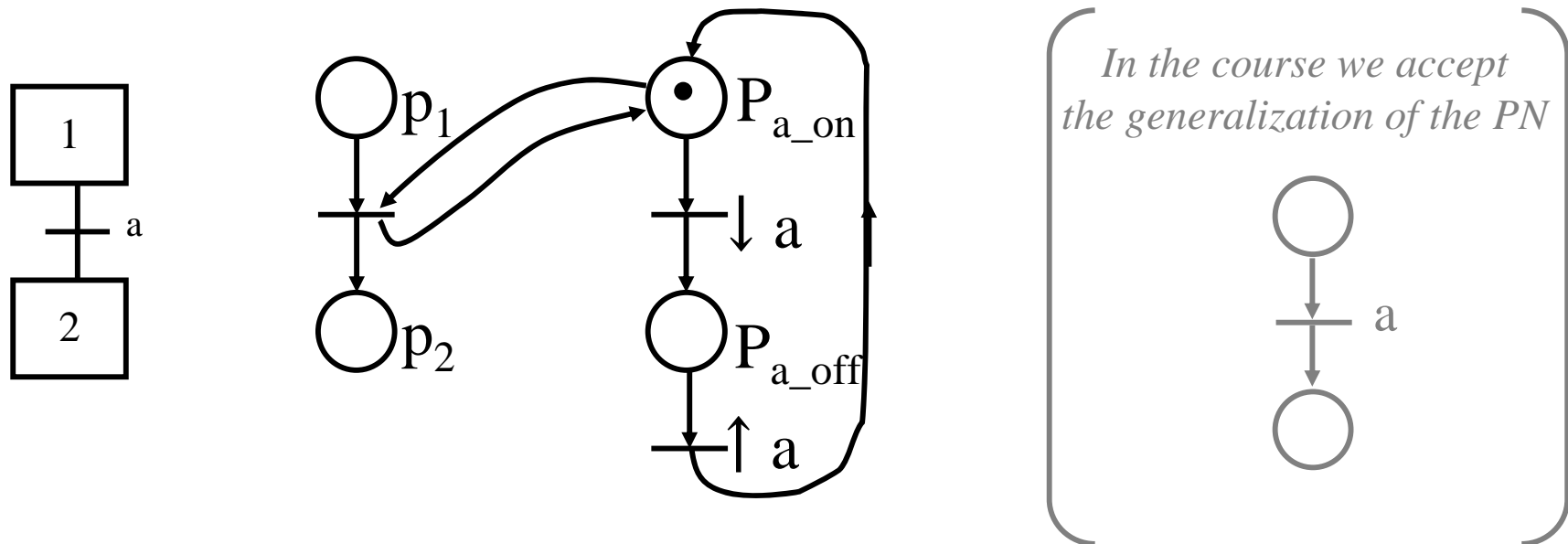

Analysis of solutions

GRAFCET → Petri Nets

Representation of variables active at edge

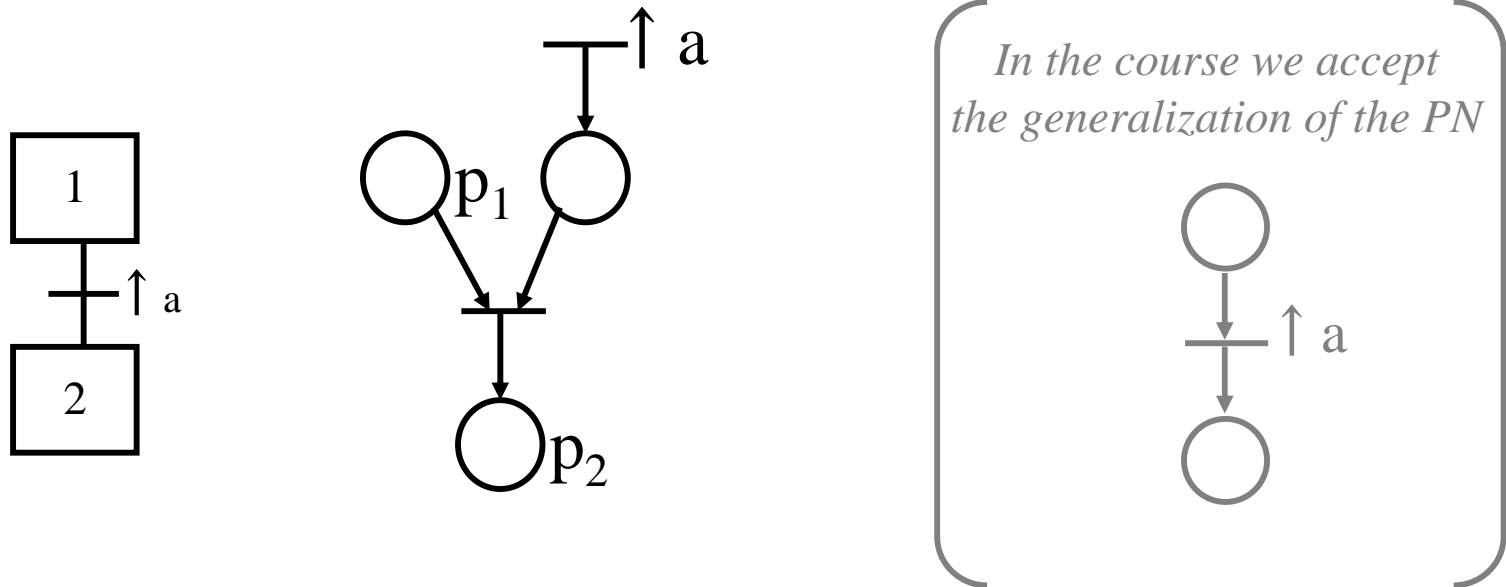

Analysis of solutions

Petri Nets → GRAFCET

Adaptation of Tools:

- 1) Reachability Tree → Reachability Graph
- 2) Method of the Matrix Equations
to describe the state evolution

Petri Nets → GRAFCET

Reachability Graph

Is a graph containing the **reachable makings**.

Is composed by two types of nodes:

- **terminal**
- **interior**

The **duplicated** nodes are not represented.

They become connected to the respective copies.

~~The symbol infinity (ω) is introduced,
to obtain finite trees, when a marking covers other(s).~~

Petri Nets → GRAFCET

Reachability Graph

Theorem - If a reachability graph has **terminal nodes** then the corresponding GRAFCET has **deadlocks**.

This method will be used to study the properties introduced in Chapter 6.

Petri Nets → GRAFCET

Reachable Set

Given the GRAFCET $G=(S, T, I, O, \mu_0)$ with initial marking μ_0 , the set of all markings that are reachable is the **reachable set** $\mu' \in R(C, \mu)$.

Remark: the Reachable Set **is not infinite!**

Given a GRAFCET with m steps it has at most 2^m nodes.

Petri Nets → GRAFCET

Safeness, Boundness and Limitation

The GRAFCET $G=(S, T, I, O, \mu_0)$ is always secure!

The same does not occur with some auxiliary elements of the GRAFCET, e.g., counters and buffers.

For those elements the analysis methods studied for Petri Nets can be used directly.

Petri Nets → GRAFCET

Conservation

A GRAFCET $G=(S, T, I, O, \mu_0)$ is **strictly conservative** if for all $\mu' \in R(C, \mu)$

$$\sum_{p_i \in P} \mu'(p_i) = \sum_{p_i \in P} \mu(p_i).$$

A GRAFCET $G=(S, T, I, O, \mu_0)$ is **conservative** if there exist a weight vector ω , without null elements, for all $\mu' \in R(C, \mu)$ such that it is constant the quantity

$$\sum_{p_i \in P} \omega(p_i) \mu(p_i).$$

Petri Nets → GRAFCET

Liveness of transitions: The transition t_j is live of

Level 0 - it can never be fired (dead transition).

Level 1 - if it is potentially firable, e.g. if there exist $\mu' \in R(C, \mu)$ such that t_j is enabled in μ' .

Level 2 - if, for each positive n , there exist a sequence of firings where occurs n firings of t_j .

Level 3 - if there exist a sequence of firings where an infinite number of firings of t_j occurs.

Level 4 - if for each $\mu' \in R(C, \mu)$ there exist a sequence σ that enables the firing of t_j (live transition).

Petri Nets → GRAFCET

Example of GRAFCET

- t_4 is level 0.
- t_1 is level 3.
- t_2 is level 3.
- t_3 is level 1.

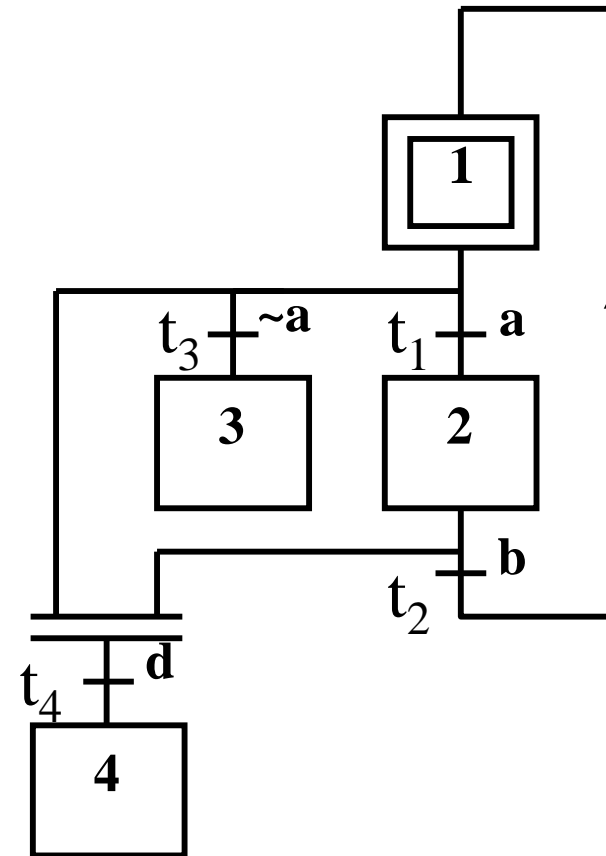

Petri Nets \rightarrow GRAFCET

Example of GRAFCET

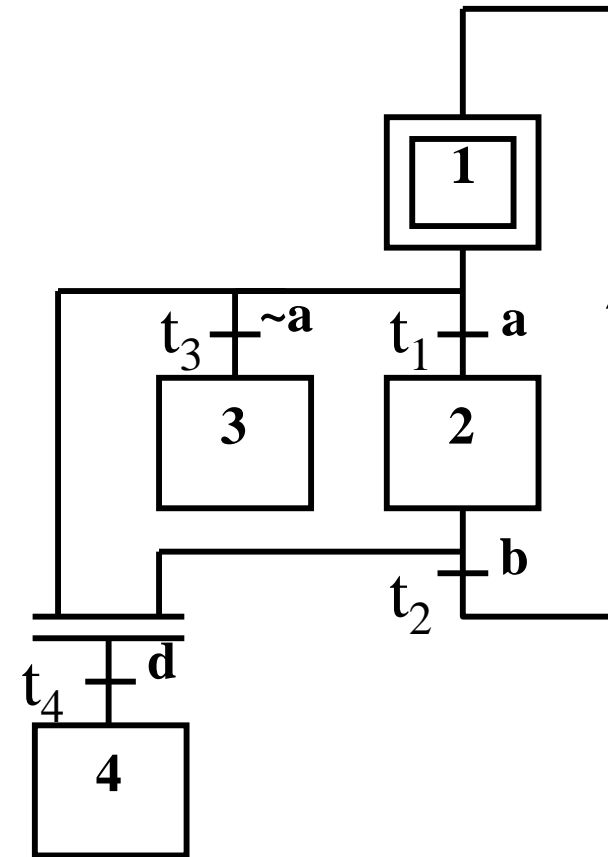
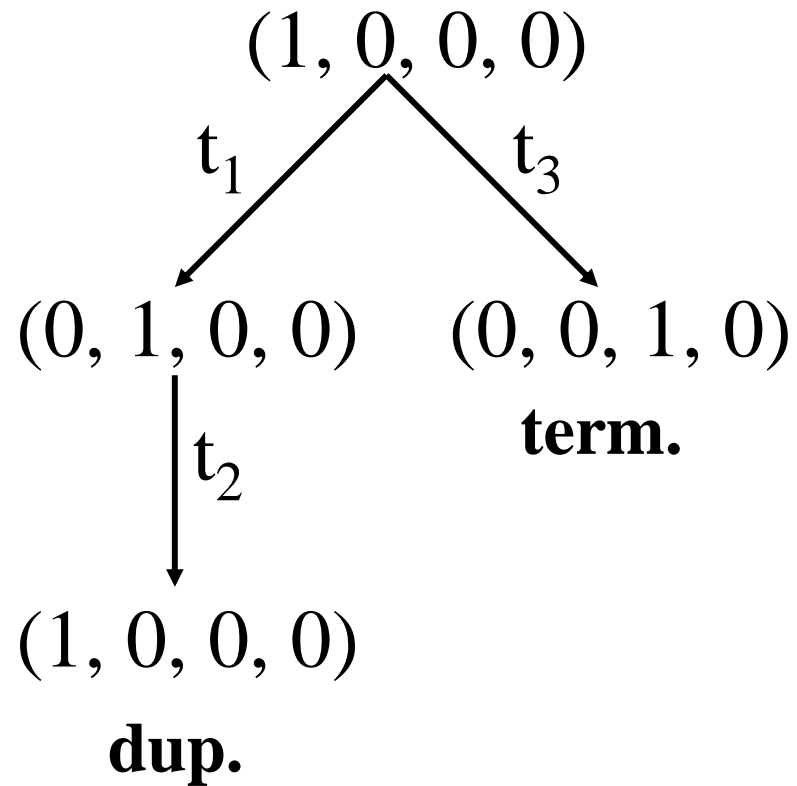

Petri Nets → GRAFCET

Example of GRAFCET

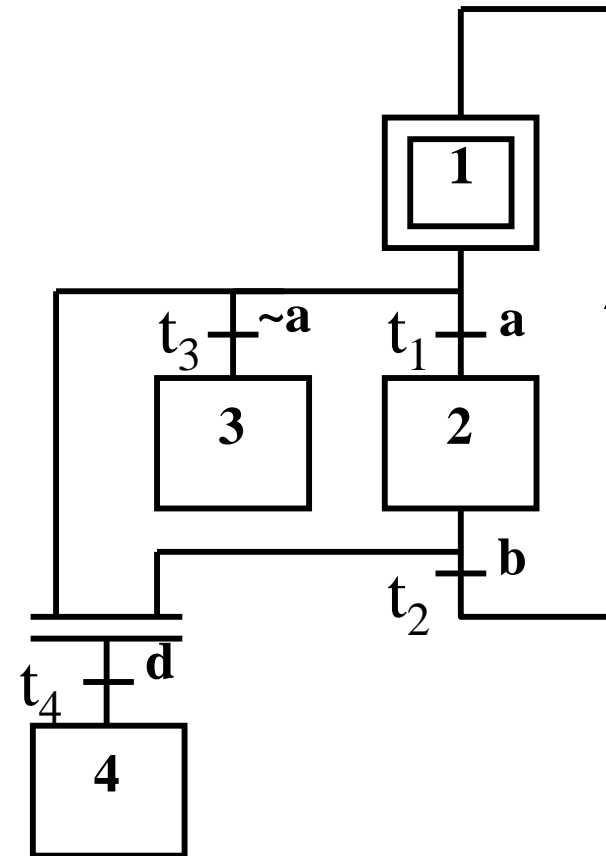
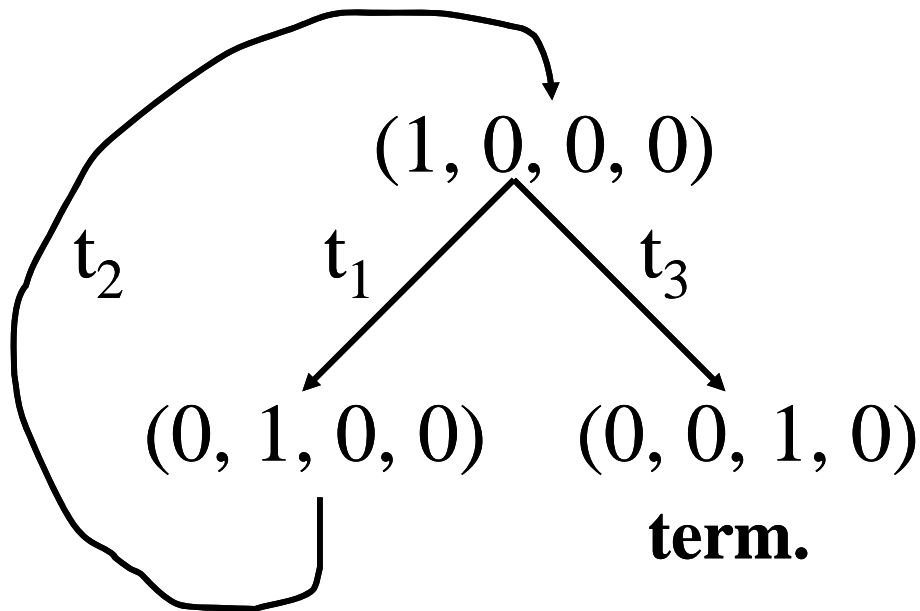

Strictly conservative.

Petri Nets → GRAFCET

Method of Matrix Equation (for the state evolution)

The evolution of a GRAFCET can be written in compact form as:

$$\mu' = \mu + Dq$$

where:

- μ' - desired marking (vector column vector)
- μ - initial marking
- q - column vector of the transition firings
- D - incidence matrix. Accounts for the token evolution as a consequence of transitions firing.

Petri Nets → GRAFCET

Problems that can be addressed resorting to the Method of Matrix Equations

- **Reachability** (sufficient condition)

Theorem – if the problem of finding the vector of firings, for a GRAFCET without conflicts, from the state μ to the state μ' has no solution using the Method of Matrix Equations, then the problem of reachability of μ' is impossible.

- **Conservation** – the conservation vector can be computed automatically.
- **Temporal invariance** – cycles of operation can be found.

Example of GRAFCET

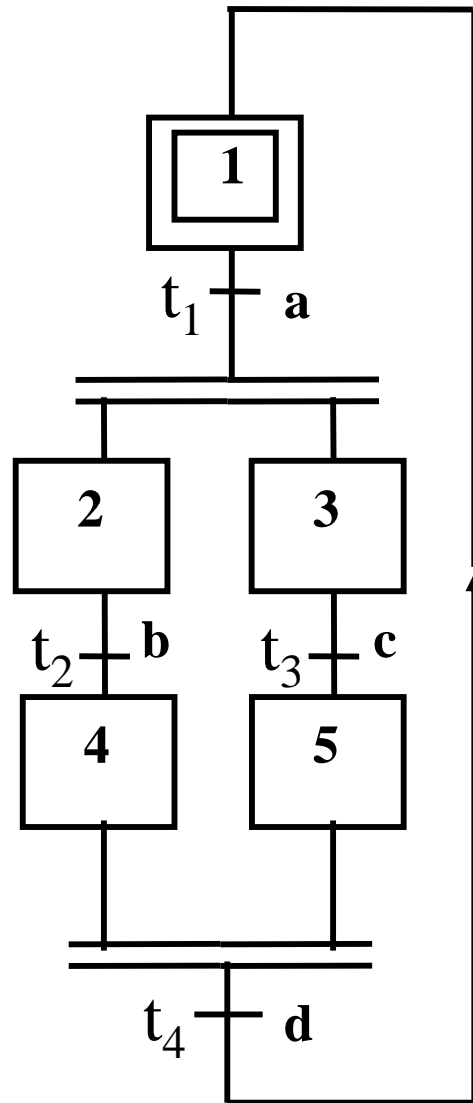

$$\mu' = \mu + Dq$$

$$D = \begin{bmatrix} -1 & 0 & 0 & 1 \\ 1 & -1 & 0 & 0 \\ 1 & 0 & -1 & 0 \\ 0 & 1 & 0 & -1 \\ 0 & 0 & 1 & -1 \end{bmatrix}$$

Conservation $x^T D = 0$

$$\begin{cases} -x_1 + x_2 + x_3 = 0 \\ -x_2 + x_4 = 0 \\ -x_3 + x_5 = 0 \\ x_1 - x_4 - x_5 = 0 \end{cases}$$

$$\begin{aligned} x_1 &= x_3 + x_4 \\ x_1 &= x_2 + x_5 \\ x_2 + x_3 &= x_4 + x_5 \end{aligned}$$

Solution:
Undetermined
set of equations

$$x = \begin{bmatrix} 2 \\ 1 \\ 1 \\ 1 \\ 1 \end{bmatrix}$$

Example of GRAFCET

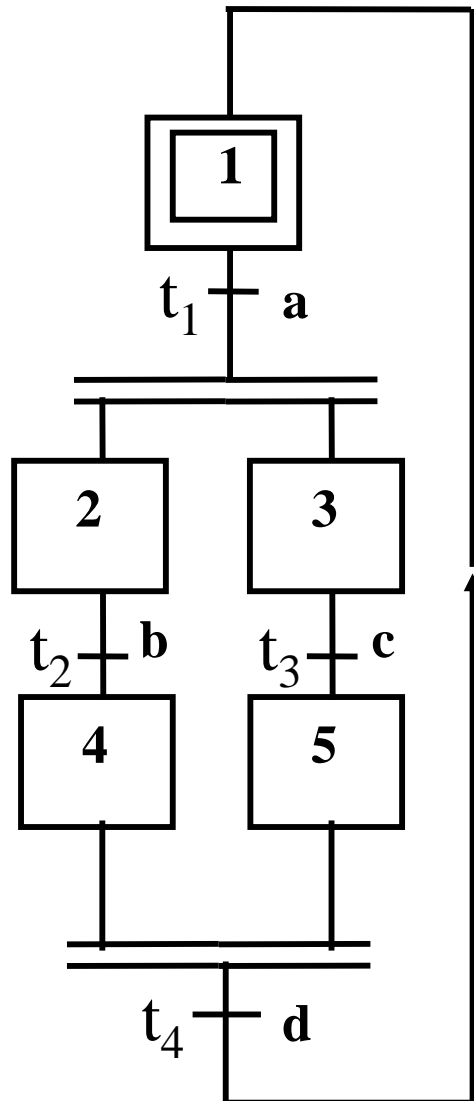

$$\mu' = \mu + Dq$$

$$Dq = 0$$

$$D = \begin{bmatrix} -1 & 0 & 0 & 1 \\ 1 & -1 & 0 & 0 \\ 1 & 0 & -1 & 0 \\ 0 & 1 & 0 & -1 \\ 0 & 0 & 1 & -1 \end{bmatrix} \quad q = \begin{bmatrix} \sigma_1 \\ \sigma_2 \\ \sigma_3 \\ \sigma_4 \end{bmatrix}$$

Temporal invariance

Solution:
Set of equations
with solution

$$\begin{cases} -\sigma_1 + \sigma_4 = 0 \\ \sigma_1 - \sigma_2 = 0 \\ \sigma_1 - \sigma_3 = 0 \\ \sigma_2 - \sigma_4 = 0 \\ \sigma_3 - \sigma_4 = 0 \end{cases}$$

$$\sigma_1 = \sigma_2 = \sigma_3 = \sigma_4 = 1.$$

Example of GRAFCET

$$\mu' = \mu + Dq$$

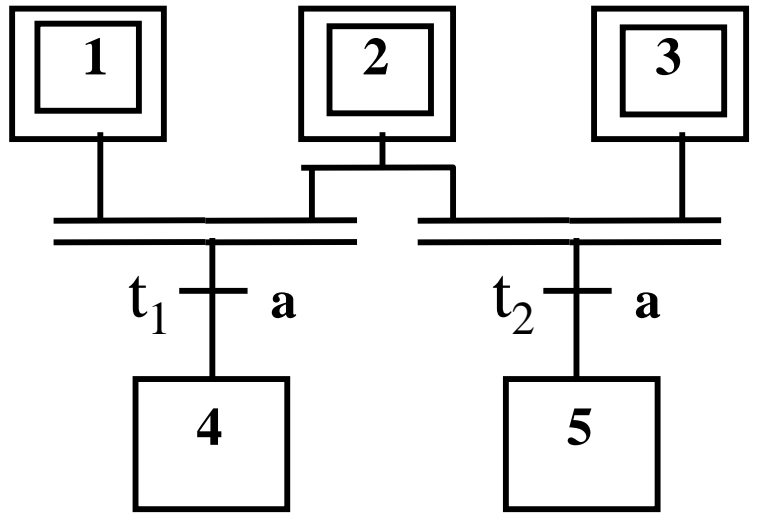

$$\mu' = \begin{bmatrix} 0 \\ 0 \\ 0 \\ 1 \\ 1 \end{bmatrix} \quad \mu = \begin{bmatrix} 1 \\ 1 \\ 1 \\ 0 \\ 0 \end{bmatrix} \quad D = \begin{bmatrix} -1 & 0 \\ -1 & -1 \\ 0 & -1 \\ 1 & 0 \\ 0 & 1 \end{bmatrix} \quad q = \begin{bmatrix} \sigma_1 \\ \sigma_2 \end{bmatrix}$$

Set of Equations is **impossible**
therefore the marking is **not reachable...**

WRONG !

The method fails if there are conflicts!

$$\left\{ \begin{array}{l} 0 = 1 - \sigma_1 \\ 0 = 1 - \sigma_1 - \sigma_2 \\ 0 = 1 - \sigma_2 \\ 1 = \sigma_1 \\ 1 = \sigma_2 \end{array} \right.$$