

# **Industrial Automation**

## **(Automação de Processos Industriais)**

### **PLC Programming languages**

### **Ladder Diagram**

<http://users.isr.ist.utl.pt/~jag/courses/api1314/api1314.html>

Slides 2010/2011 Prof. Paulo Jorge Oliveira

Rev. 2011-2014 Prof. José Gaspar

# Syllabus:

**Chap. 2 – Introduction to PLCs [2 weeks]**

...

**Chap. 3 – PLC Programming languages [2 weeks]**

Standard languages (IEC-61131-3):

*Ladder Diagram; Instruction List, and Structured Text.*

Software development resources.

...

**Chap. 4 - GRAFCET (*Sequential Function Chart*) [1 week]**

# PLC Programming languages (IEC 1131-3 changed to IEC 61131-3)

## *Ladder Diagram*

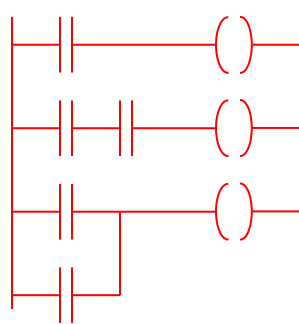

## *Structured Text*

```

If %I1.0 THEN
    %Q2.1 := TRUE
ELSE
    %Q2.2 := FALSE
END_IF
    
```

## *Instruction List*

LD	%M12
AND	%I1.0
ANDN	%I1.1
OR	%M10
ST	%Q2.0

## *Sequential Function Chart (GRAFCET)*

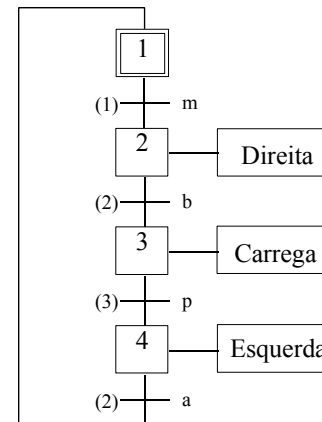

# Ladder diagram

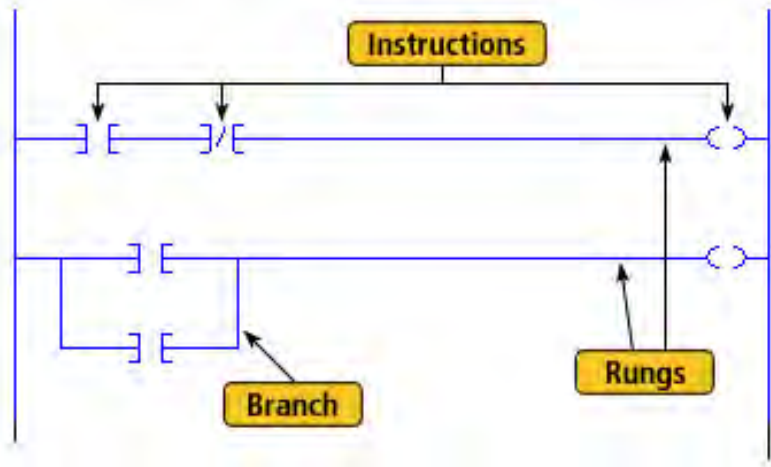

A **program** is a series of instructions that directs the PLC to execute actions.

**Relay ladder logic**, the standard programming language, is based on electromagnetic relay control.

Input Instructions

Output Instructions

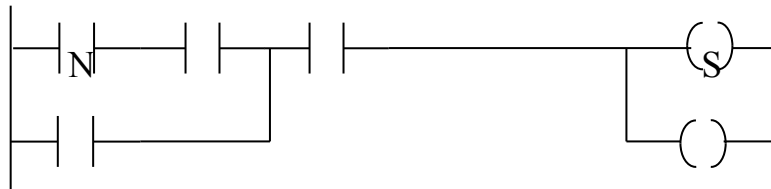

# Ladder diagram      Types of operands in Schneider DMY 28FK:

**CPU objects**

System:  %S  %SW

Memory:  %M  %MW  %MD  %MF  %KW  %KD  %KF

---

**I/O Objects**

Channel:  %CH

Configuration:  %KW  %KD  %KF

System:  %MW

Status:  %MW

Parameter:  %MW  %MD  %MF

Command:  %MW  %MD  %MF

Implicits:  %I  %IW  %ID  %IF  %IERR

%Q  %QW  %QD  %QF

---

**Update**

addresses

names, types and comments

usages

	Address	Name	Type	Comment
1	%I0.3.0		EBOOL	
2	%I0.3.1		EBOOL	
3	%I0.3.2		EBOOL	
4	%I0.3.3		EBOOL	
5	%I0.3.4		EBOOL	
6	%I0.3.5		EBOOL	
7	%I0.3.6		EBOOL	
8	%I0.3.7		EBOOL	
9	%I0.3.8		EBOOL	
10	%I0.3.9		EBOOL	
11	%I0.3.10		EBOOL	
12	%I0.3.11		EBOOL	
13	%I0.3.12		EBOOL	
14	%I0.3.13		EBOOL	
15	%I0.3.14		EBOOL	
16	%I0.3.15		EBOOL	
17	%Q0.3.16		EBOOL	
18	%Q0.3.17		EBOOL	
19	%Q0.3.18		EBOOL	
20	%Q0.3.19		EBOOL	
21	%Q0.3.20		EBOOL	
22	%Q0.3.21		EBOOL	
23	%Q0.3.22		EBOOL	
24	%Q0.3.23		EBOOL	
25	%Q0.3.24		EBOOL	
26	%Q0.3.25		EBOOL	

## Ladder diagram    Types of operands:

Bits	Description	Examples	Write access
Immediate values	0 or 1 (False or True)	0	–
Inputs/outputs	<p>These bits are the "logic images" of the electrical states of the inputs/ outputs. They are stored in the data memory and updated each time the task in which they are configured is polled.</p> <p><b>Note:</b> The unused input/output bits may not be used as internal bits.</p>	%I23.5 %Q51,2	No Yes
Internal	The internal bits are used to store the intermediary states during execution of the program.	%M200	Yes
System	The system bits %S0 to %S127 monitor the correct operation of the PLC and the running of the application program.	%S10	According to i
Function blocks	The function block bits correspond to the outputs of the function blocks or DFB instance. These outputs may be either directly connected or used as an object.	%TM8.Q	No
Word extracts	With the PL7 software it is possible to extract one of the 16 bits of a word object.	%MW10:X5	According to the type of words
Grafcet steps and macro-steps	The Grafcet status bits of the steps, macro-steps and macro-step steps are used to recognize the Grafcet status of step i, of macro-step j or of step i of the macro-step j.	%X21 %X5.9	Yes Yes

# Ladder diagram

## Basic Instructions

*Load*  **Normally open** contact: contact is active (result is 1) when the control bit is 1.

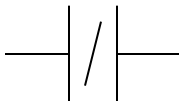
 **Normally closed** contact: contact is active (result is 1) when the control bit is 0.

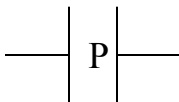
 **Contact in the rising edge**: contact is active during a scan cycle where the control bit has a rising edge.

 **Contact in the falling edge**: contact is active during a scan cycle where the control bit has a falling edge.

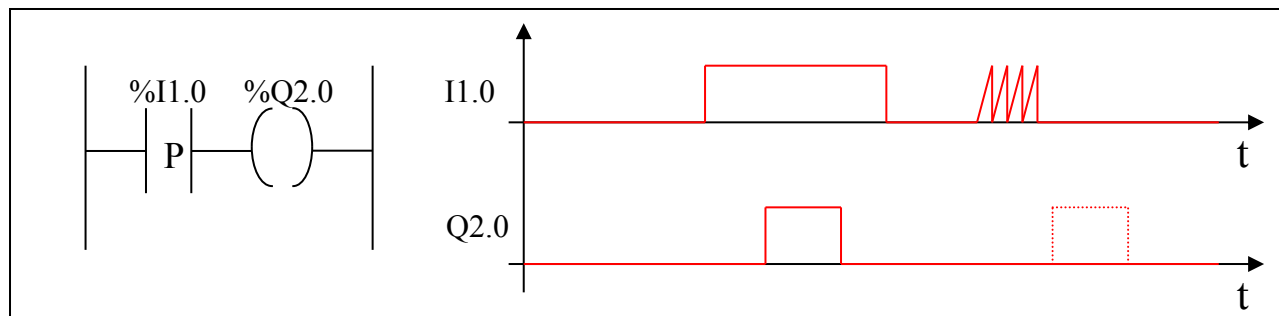

## Ladder diagram

### Basic Instructions

#### *Load operands*

##### Permitted operands

The following table gives a list of the operands used for these instructions.

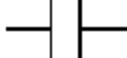
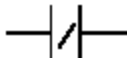
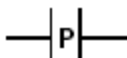
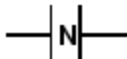
Ladder	Instruction list	Structured text	Operands
	LD	:=	%I,%Q,%M,%S,%BLK,%•:Xk, %Xi, (True and False in instruction list or structured text)
	LDN	:=NOT	%I,%Q,%M,%S,%BLK,%•:Xk, %Xi, (True and False in instruction list or structured text)
	LDR	:=RE	%I,%Q,%M
	LDF	:=FE	%I,%Q,%M



## Ladder diagram

### Basic Instructions

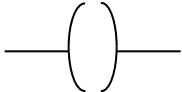
*Store*  The result of the logic function activates the coil.

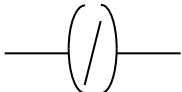
 The inverse result of the logic function activates the coil.

 The result of the logic function energizes the relay (sets the latch).

 The result of the logic function de-energizes the relay (resets the latch)..

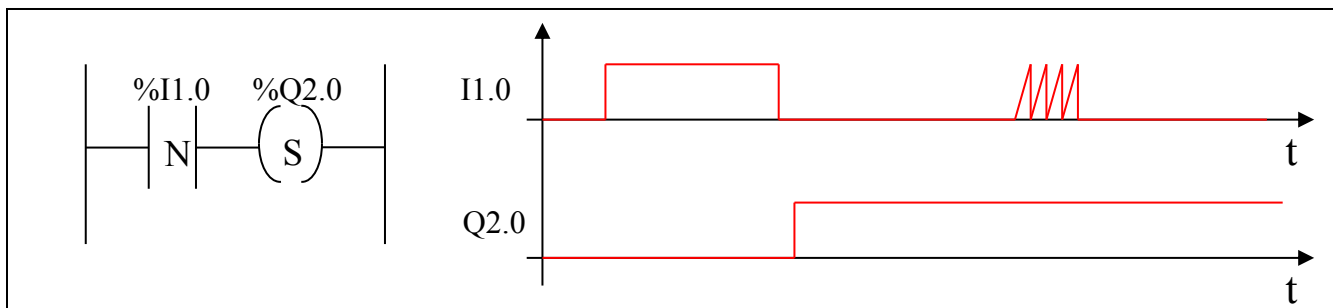



# Ladder diagram

## Basic Instructions

### *Store operands*

**Permitted operands**

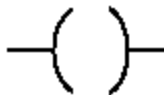
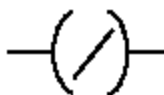
The following table gives a list of the operands used for these instructions

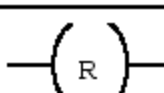
Language data	Instruction list	Structured text	Operands
	ST	:=	%I,%Q,%M,%S,%•:Xk
	STN	:=NOT	%I,%Q,%M,%S,%•:Xk
	S	SET	%I,%Q,%M,%S,%•:Xk,%Xi Only in the preliminary processing.
	R	RESET	%I,%Q,%M,%S,%•:Xk,%Xi Only in the preliminary processing.

# Ladder diagram

## Allen Bradley notation

### Relays with *latch* and *unlatch*

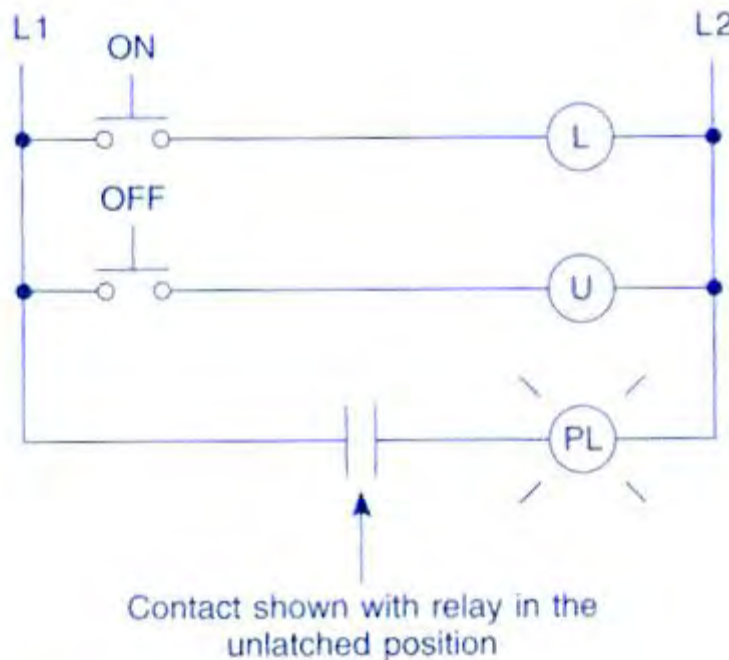

**Fig. 6-50**

Schematic of electromagnetic latching relay.

Instruction	Symbol	Mnemonic
Output latch	-(L)-	OTL
Output unlatch	-(U)-	OTU

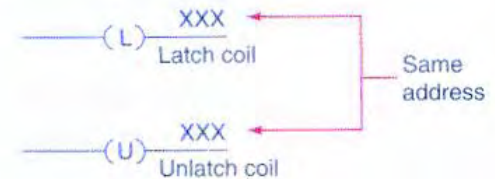

(a) Latch and unlatch coils have the same address

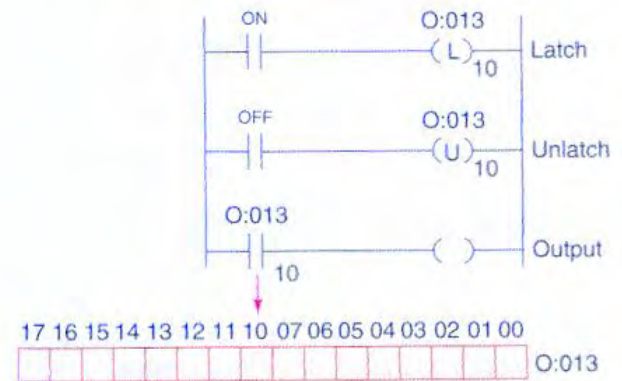

(b) Control logic

**Fig. 6-51**

OUTPUT LATCH and OUTPUT UNLATCH instructions.

# Ladder diagram

## Relay-type instructions

*Example:*

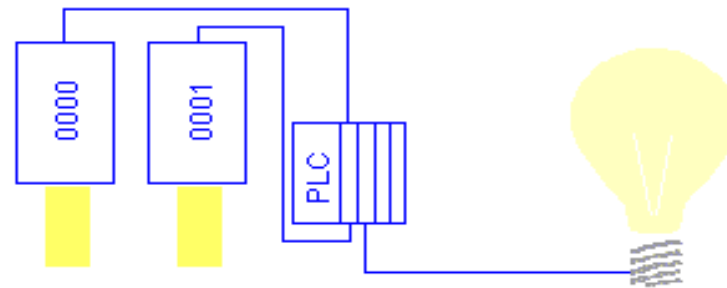
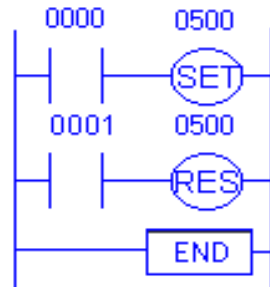
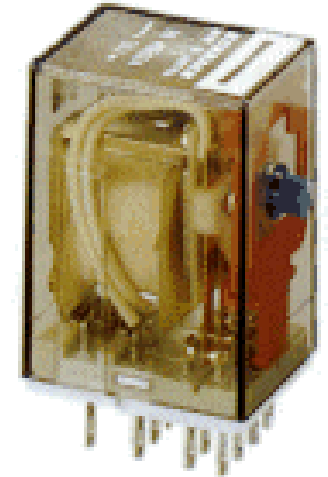
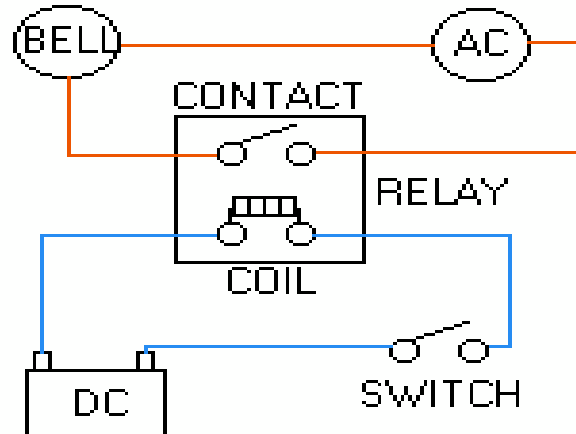

# Ladder diagram

## Basic Instructions

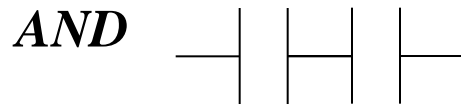

AND of the operand with the result of the previous logical operation.

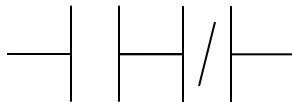

AND of the operand with the inverted result of the previous logical operation.

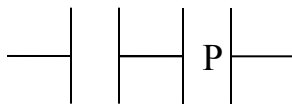

AND of the rising edge with the result of the previous logical operation.

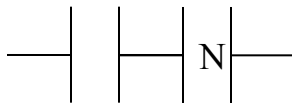

AND of the falling edge with the result of the previous logical operation.

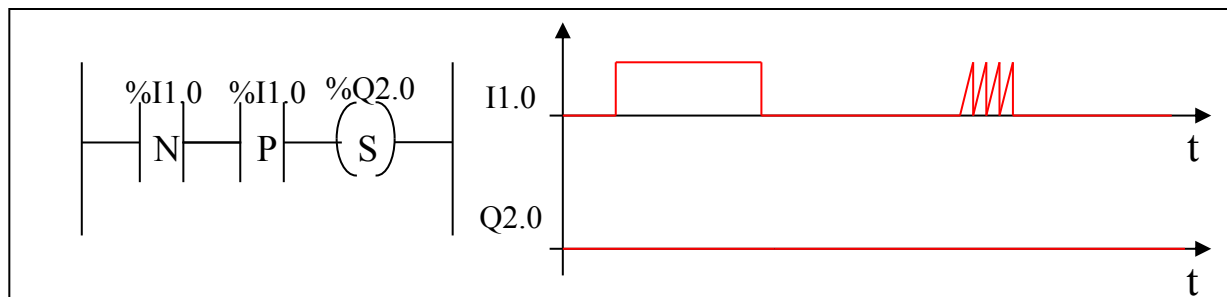

## Ladder diagram

### Basic Instructions

*OR*

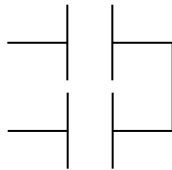

OR of the operand with the result of the previous logical operation.

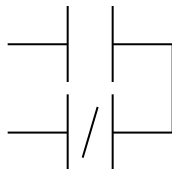

OR of the operand with the inverted result of the previous logical operation.

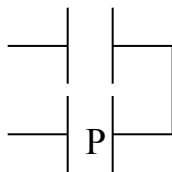

OR of the rising edge with the result of the previous logical operation.

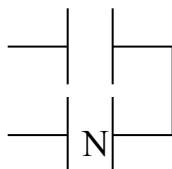

OR of the falling edge with the result of the previous logical operation.

# Ladder diagram

## Basic Instructions

### XOR

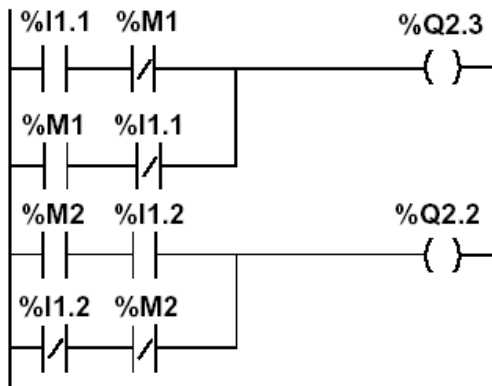

```

%Q2.3 := %I1.1 XOR %M1;
%Q2.2 := NOT(%M2 XOR %I1.2);
%Q2.2 := %M2 XOR NOT(%I1.2);
    
```

Instruction list	Structured text	Description	Timing diagram
XOR	XOR	OR Exclusive between the operand and the previous instruction's Boolean result	
XORN	XOR (NOT...)	OR Exclusive between the operand inverse and the previous instruction's Boolean result	
XORR	XOR (RE...)	OR Exclusive between the operand's rising edge and the previous instruction's Boolean result	
XORF	XOR (FE...)	OR Exclusive between the operand's falling edge and the previous instruction's Boolean result	

## Ladder diagram

### Ladder assembling

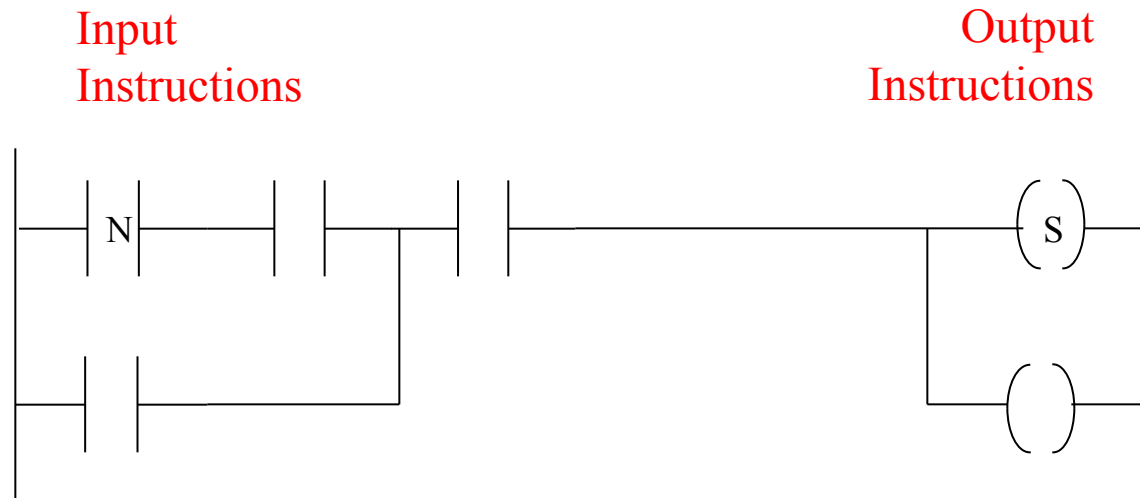

The outputs that have a TRUE logical function, evaluated from the left to right and from the top to the bottom, are energized (Schneider, Micro PLCs).



# Ladder diagram

Example:

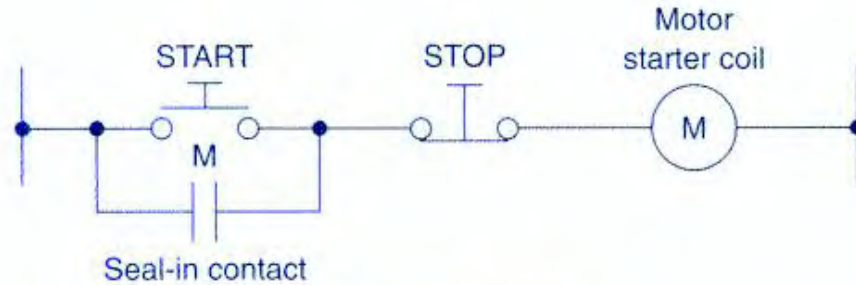

(a) Hard-wired circuit

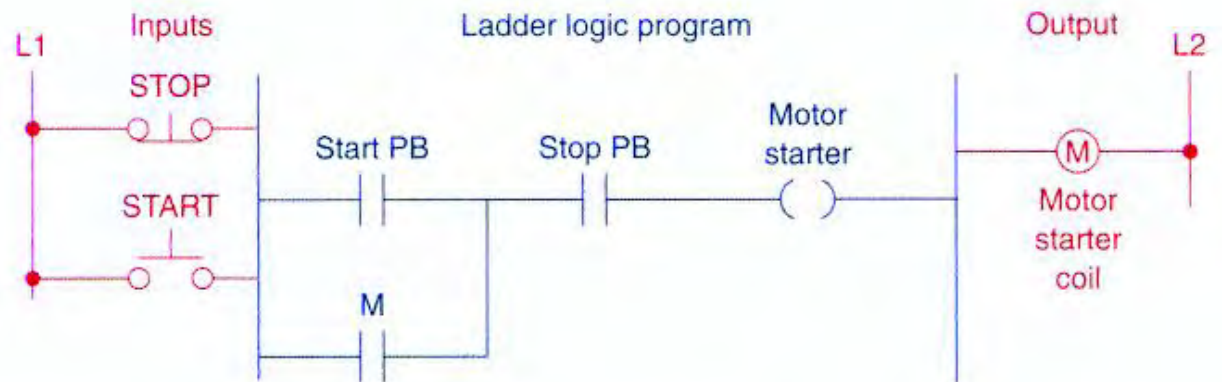

(b) Programmed circuit

**Fig. 6-48**

Seal-in circuit.

# Ladder diagram

## Example:

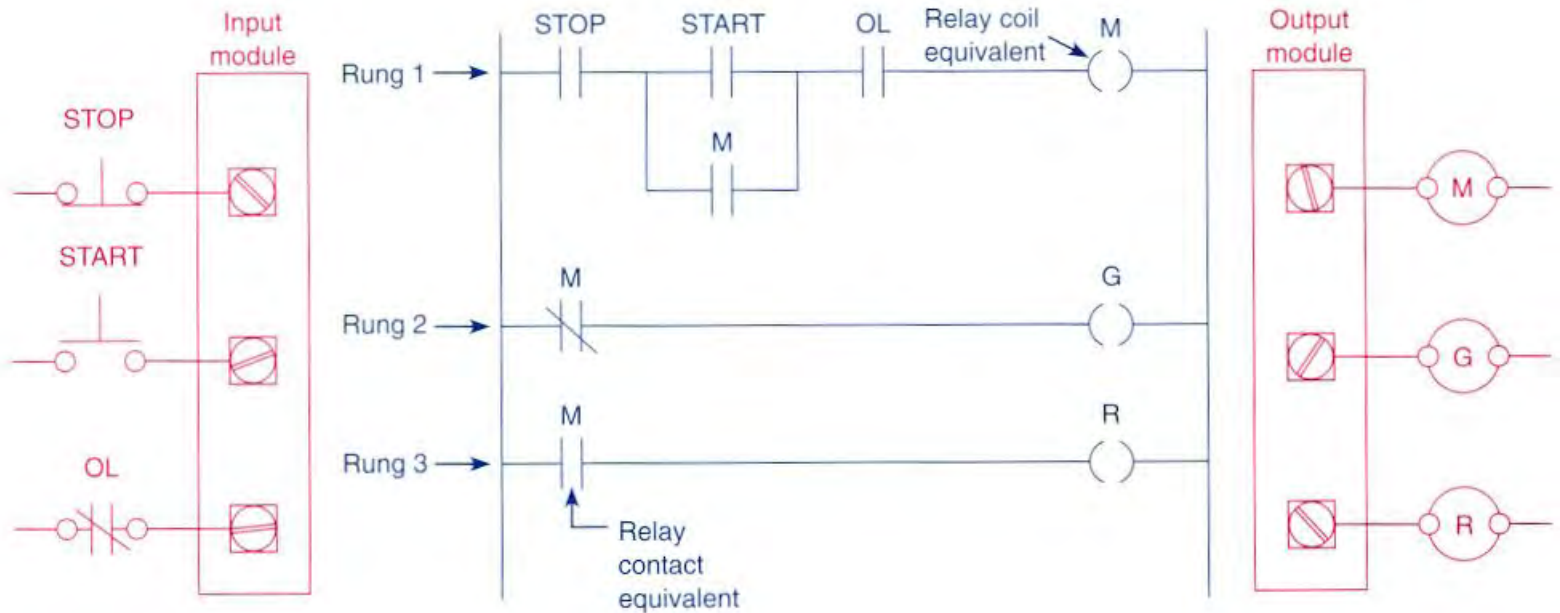
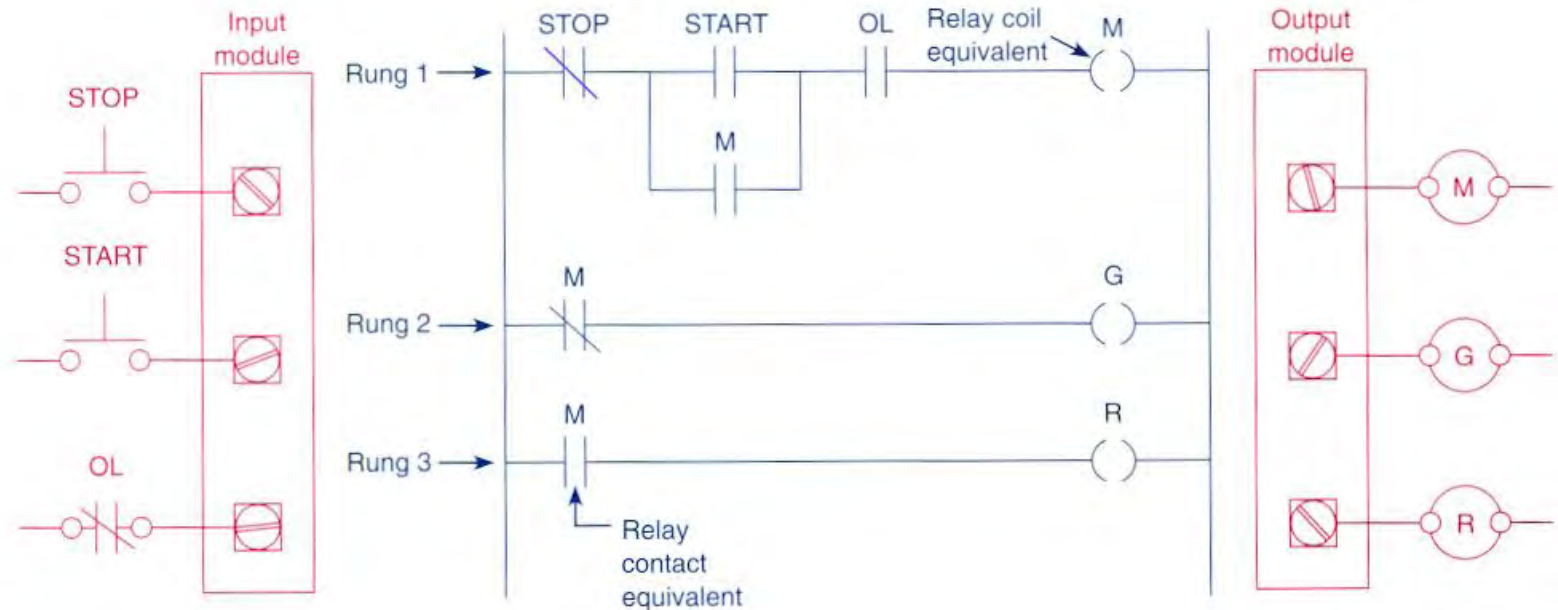

**Fig. 4-24**

Ladder logic program.

## Ladder diagram

### Example:



If the Stop PB is normally open, then invert its logic in the ladder diagram.

# Ladder diagram

## Example:

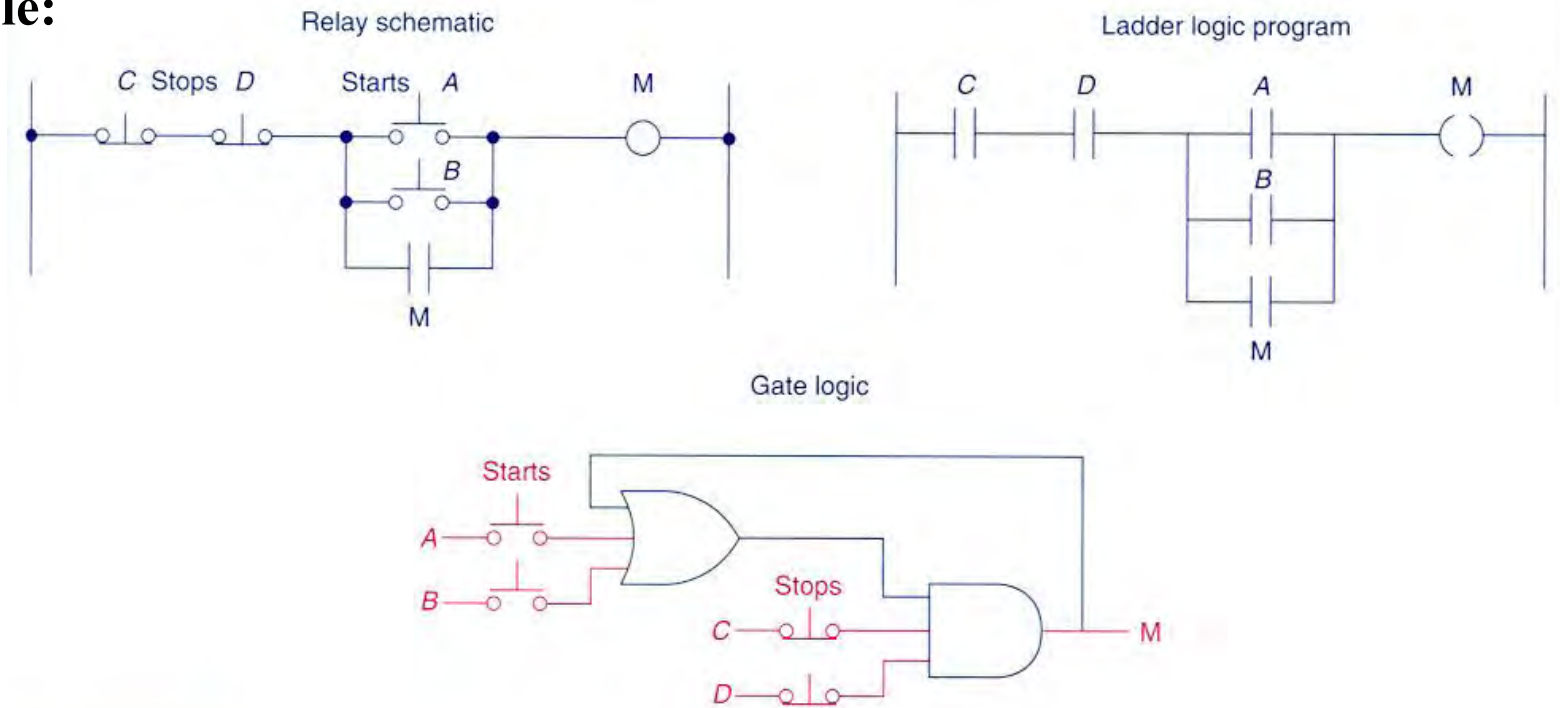

### Example 4-9

A motor control circuit with two stop buttons. When the start button is depressed, the motor runs. By sealing, it continues to run when the start button is released. The stop buttons stop the motor when they are depressed.

# Ladder diagram

General case of Inputs and Outputs in **parallel**, with **derivations**

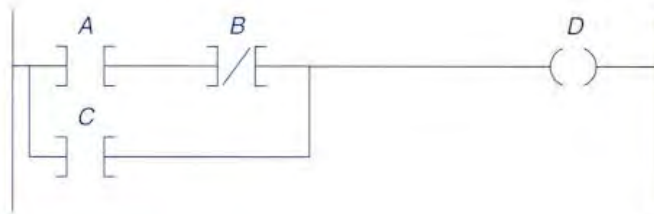

**Fig. 5-21**  
Parallel input branching.

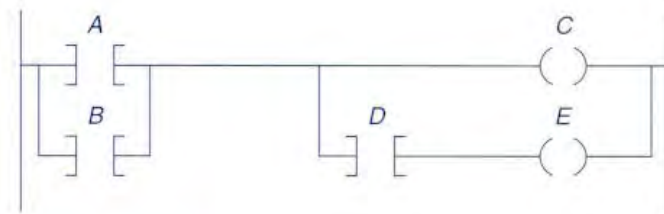

**Fig. 5-23**  
Parallel output branching with conditions.



**Fig. 5-22**  
Parallel output branching.

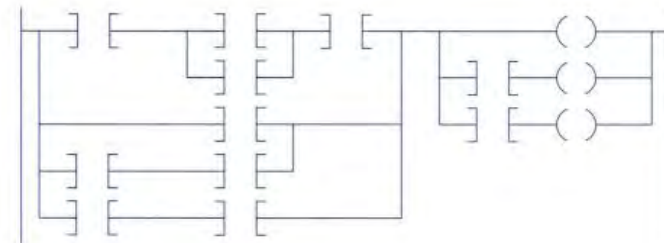
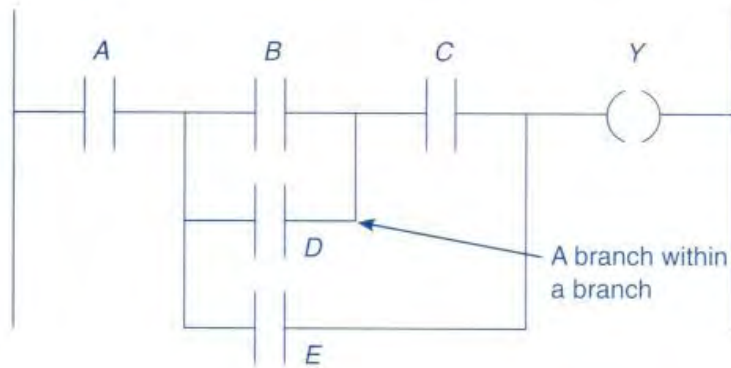

**Fig. 5-24**  
Nested input and output branches.

Note: it is important to study the **constraints** and **potentialities** of the development tools.

# Ladder diagram

**Imbricated** (nested) contacts and **alternative** solution



**Fig. 5-25**  
Nested contact program.

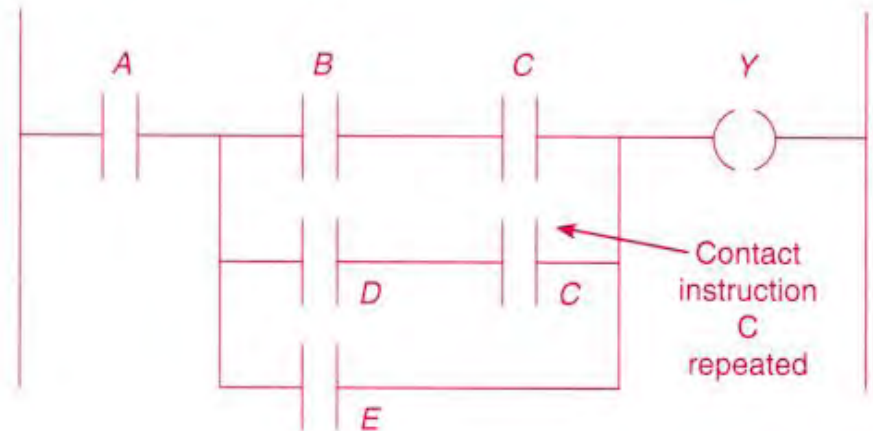

**Fig. 5-26**  
Program required to eliminate nested contact.

# Ladder diagram

Contacts in the **vertical** and **alternative** solution

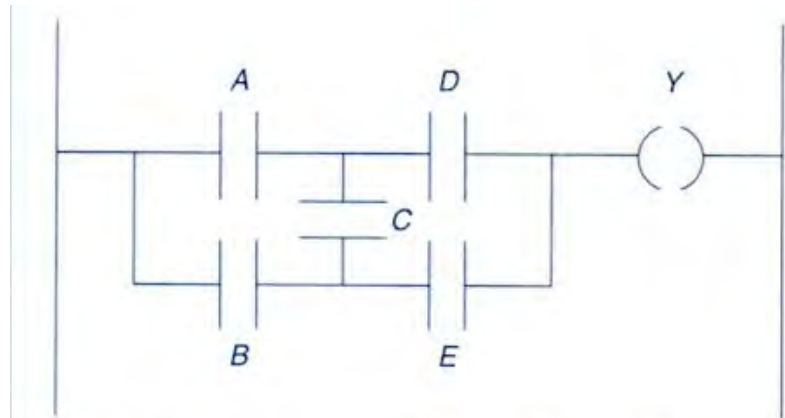

Boolean equation:  $Y = (AD) + (BCD) + (BE) + (ACE)$

**Fig. 5-28**

Program with vertical contact

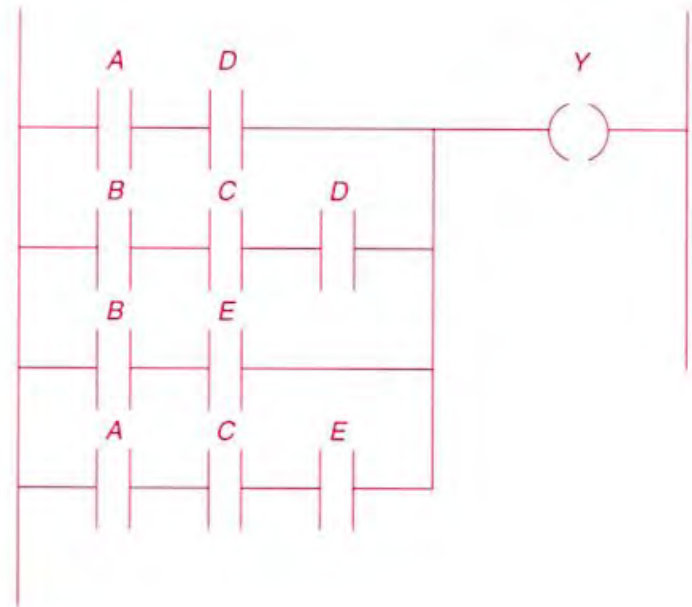

**Fig. 5-29**

Reprogrammed to eliminate vertical contact.

## Ladder diagram

Contacts in the **vertical** and **alternative** solution

Another example:

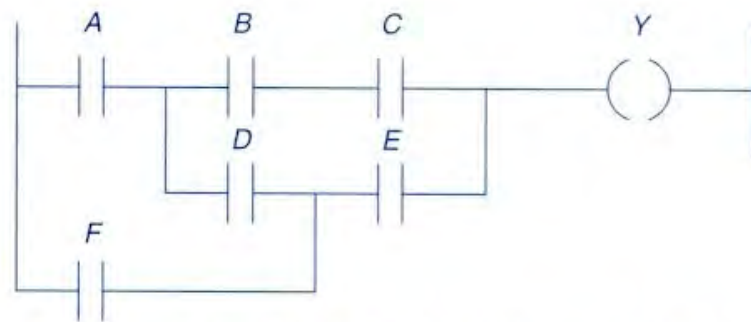

Boolean equation:  $Y = (ABC) + (ADE) + (FE) + (FDBC)$

**Fig. 5-30**

Original circuit.

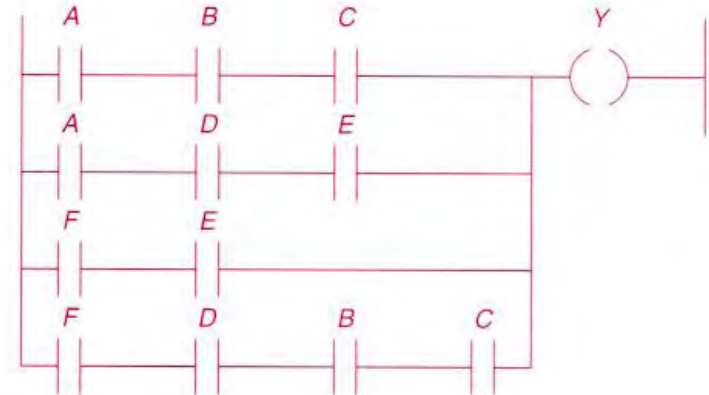

**Fig. 5-31**

Reprogrammed circuit.

*Solves the problem of disallowed right to left scanning (FDBC in fig5.30).*



**Ladder diagram**     *Temporized Relays or Timers*



**Solid-state timing relay**



**Pneumatic timing relay**



**Plug-in timing relay**

# Ladder diagram *Temporized Relays or Timers (pneumatic)*

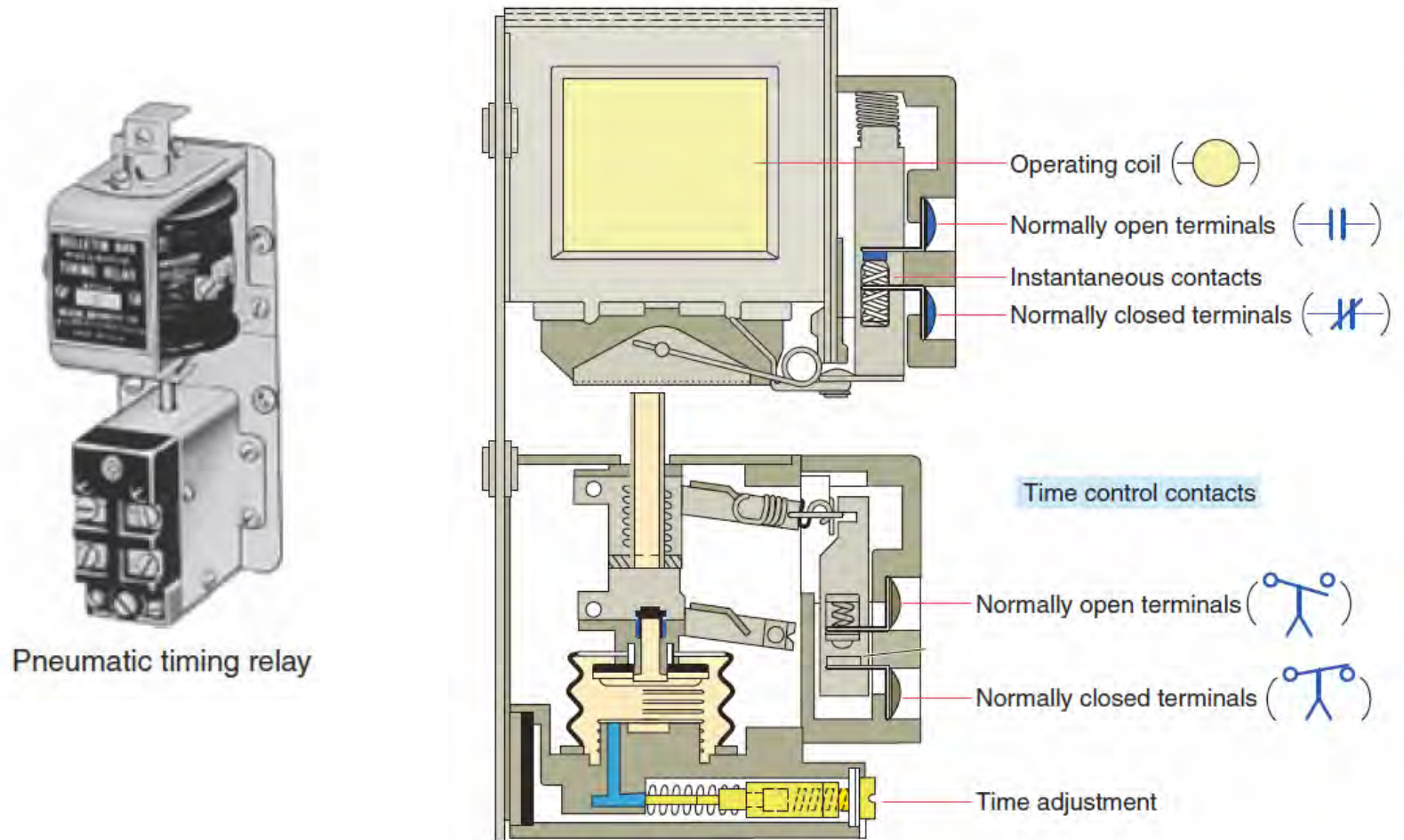

The **instantaneous** contacts change state as soon as the timer coil is powered.  
 The **delayed** contacts change state at the end of the time delay.

# Ladder diagram *Temporized Relays or Timers*

**On-delay**, provides time delay when the relay coil is energized.

**Off-delay**, provides time delay when the relay coil is de-energized.

On-delay symbols	
<p>Normally open, timed closed contact (NOTC). Contact is open when relay coil is de-energized. When relay is energized, there is a time delay in closing.</p>	<p>Normally closed, timed open contact (NCTO). Contact is closed when relay coil is de-energized. When relay is energized, there is a time delay in opening.</p>

Off-delay symbols	
<p>Normally open, timed open contact (NOTO). Contact is normally open when relay coil is de-energized. When relay coil is energized, contact closes instantly. When relay coil is de-energized, there is a time delay before the contact opens.</p>	<p>Normally closed, timed closed contact (NCTC). Contact is normally closed when relay coil is de-energized. When relay coil is energized, contact opens instantly. When relay coil is de-energized, there is a time delay before the contact closes.</p>

**Tables: Relay symbols used for timed contacts.**

# Ladder diagram *Temporized Relays or Timers*

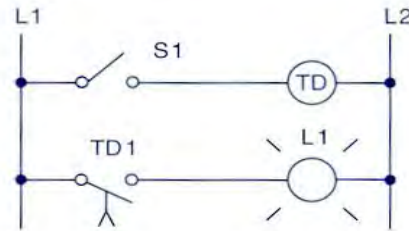

Sequence of operation:  
 S1 open, TD de-energized, TD1 open, L1 off.  
 S1 closes, TD energizes, timing period starts, TD1 is still open, L1 is still off.  
 After 10 s, TD1 closes, L1 is switched on.  
 S1 is opened, TD de-energizes, TD1 opens instantly, L1 is switched off.

(a)

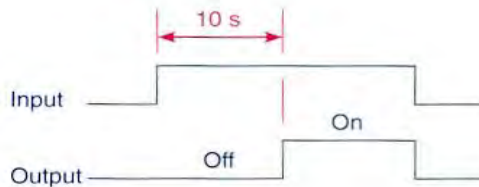

(b)

**Fig. 7-3**

On-delay timer circuit (NOTC contact). (a) Operation. (b) Timing diagram.

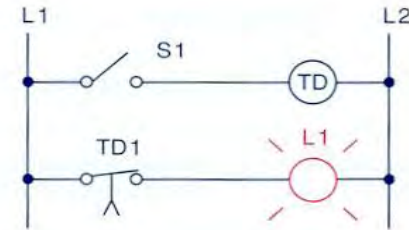

Sequence of operation:  
 S1 open, TD de-energized, TD1 closed, L1 on.  
 S1 closes, TD energizes, timing period starts, TD1 is still closed, L1 is still on.  
 After 10 s, TD1 opens, L1 is switched off.  
 S1 is opened, TD de-energizes, TD1 closes instantly, L1 is switched on.

(a)

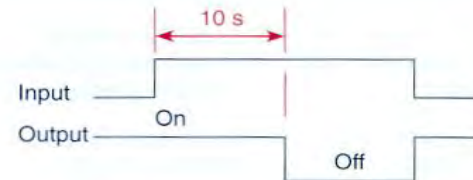

(b)

**Fig. 7-4**

On-delay timer circuit (NCTO contact). (a) Operation. (b) Timing diagram.

# Ladder diagram *Temporized Relays or Timers*

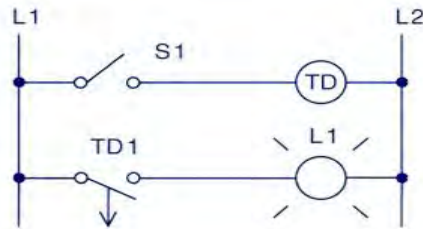

Sequence of operation:  
 S1 open, TD de-energized, TD1 open, L1 off.  
 S1 closes, TD energizes, TD1 closes instantly, L1 is switched on.  
 S1 is opened, TD de-energizes, timing period starts, TD1 is still closed, L1 is still on.  
 After 10 s, TD1 opens, L1 is switched off.

(a)

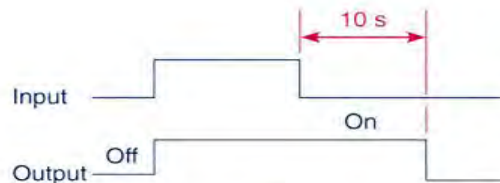

(b)

**Fig. 7-5**

Off-delay timer circuit (NOTO contact). (a) Operation. (b) Timing diagram.

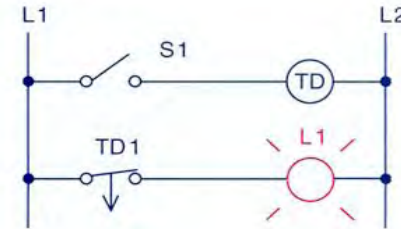

Sequence of operation:  
 S1 open, TD de-energized, TD1 closed, L1 on.  
 S1 closes, TD energizes, TD1 opens instantly, L1 is switched off.  
 S1 is opened, TD de-energizes, timing period starts, TD1 is still open, L1 is still off.  
 After 10 s, TD1 closes, L1 is switched on.

(a)

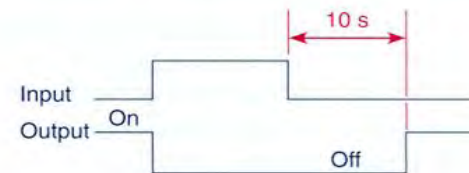

(b)

**Fig. 7-6**

Off-delay timer circuit (NCTC contact). (a) Operation. (b) Timing diagram.

# Ladder diagram

## *Temporized Relays*

## *or Timers (PLC)*

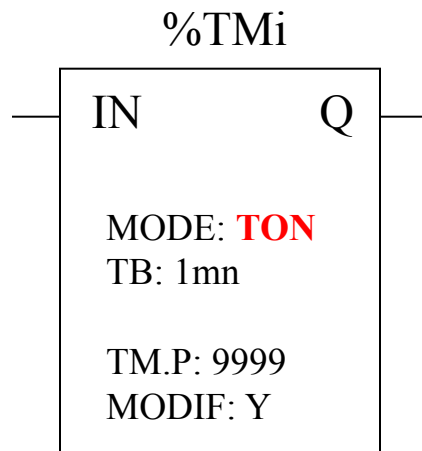

### Characteristics:

Identifier:	%Tmi	0..63 in the TSX37
Input:	IN	to activate
Mode:	<b>TON</b>	<b>Timer On delay</b>
	<b>TOF</b>	<b>Timer Off delay</b>
	<b>TP</b>	<b>Monostable</b>
Time basis:	TB	1mn (def.), 1s, 100ms, 10ms
Programmed value:	%Tmi.P	0...9999 (def.) period=TB*Tmi.P
Actual value:	%Tmi.V	0...Tmi.P (can be read or tested)
Modifiable:	Y/N	can be modified from the console

# Ladder diagram

## Temporized Relays or Timers (PLC)

**TON mode**

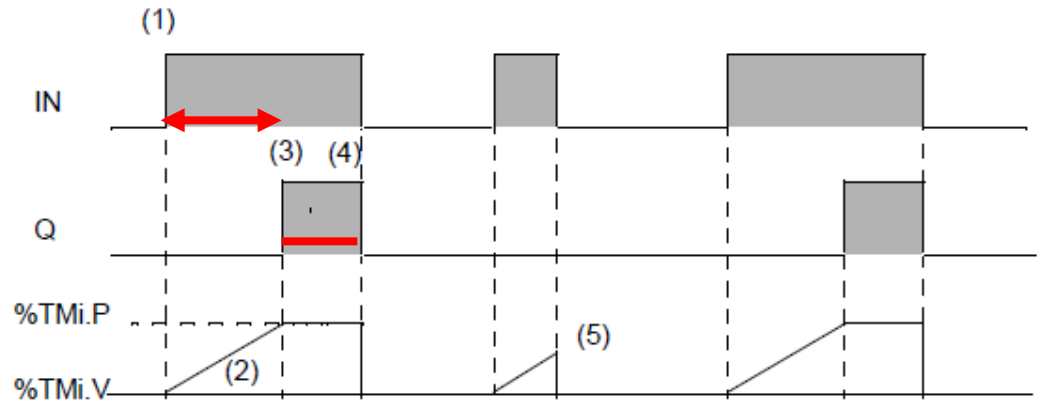
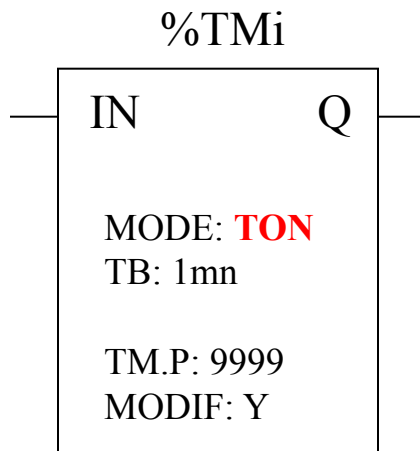

Phase	Description
1	The timer is started with a rising edge on the IN input
2	The current value %Tmi.V of the timer increases from 0 to %Tmi.P by one unit at each pulse of the time base TB
3	The %Tmi.Q output bit moves to 1 when the current value has reached %Tmi.P
4	The %Tmi.Q output bit stays at 1 while the IN input is at 1.
5	When the IN input is at 0, the timer is stopped even if it is still running: %Tmi.V takes the value 0.

*App. example: start ringing the alarm if N sec after door open there is no disarm of the alarm.*

# Ladder diagram

## Temporized Relays

## or Timers (PLC)

*TOF mode*

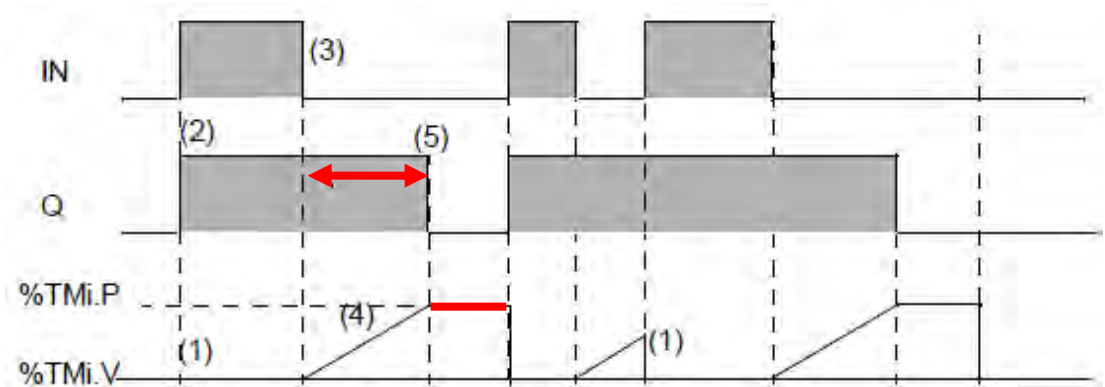
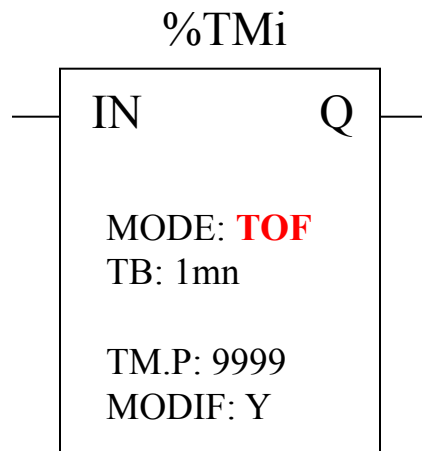

Phase	Description
1	The current value %TMi.V takes 0, on a rising edge of the IN input (even if the timer is running)
2	The %TMi.Q output bit moves to 1.
3	The timer is started with a falling edge on the IN input.
4	The current value %TMi.P increases to %TMi.P by one unit at each pulse of the time base TB.
5	The %TMi.Q output bit returns to 0 when the current value has reached %TMi.P

*App. example: turn off stairways lights after N sec the lights' button has been released.*



# Ladder diagram

*TP mode*

## Temporized Relays

### or Timers (PLC)

Works as a monostable or as a pulse generator (with pre-programmed period)

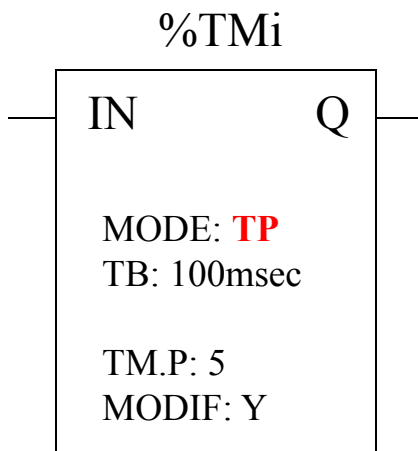
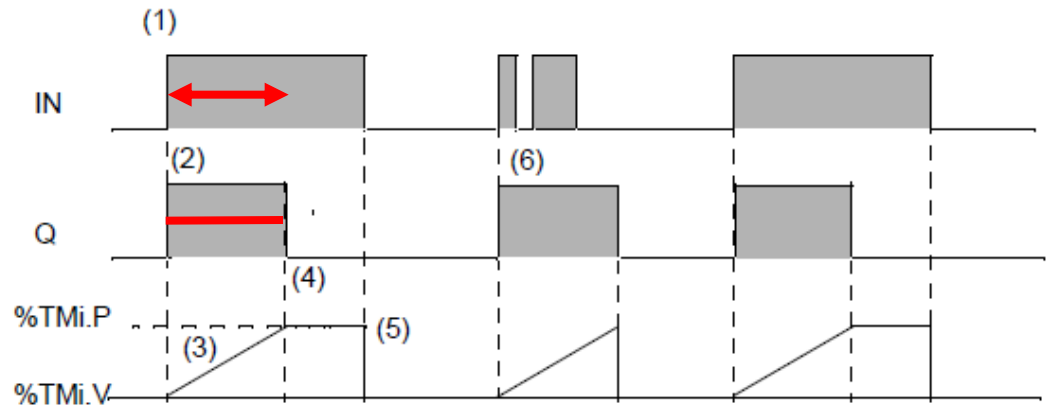

Phase	Description
1	The timer is started with a rising edge on the IN input
2	The %Tmi.Q output bit moves to 1.
3	The current value %Tmi.V of the timer increases from 0 to %Tmi.P by one unit at each pulse of the time base TB
4	The %Tmi.Q output bit returns to 0 when the current value has reached %Tmi.P.
5	When the IN input and the %Tmi.Q output are at 0, %Tmi.V takes the value 0.
6	This monostable cannot be reactivated.

*App. example: positive input edge give a controlled (fixed) duration pulse to start a motor.*

## Ladder diagram

### *Timers in PL7 vs Unity (Schneider)*

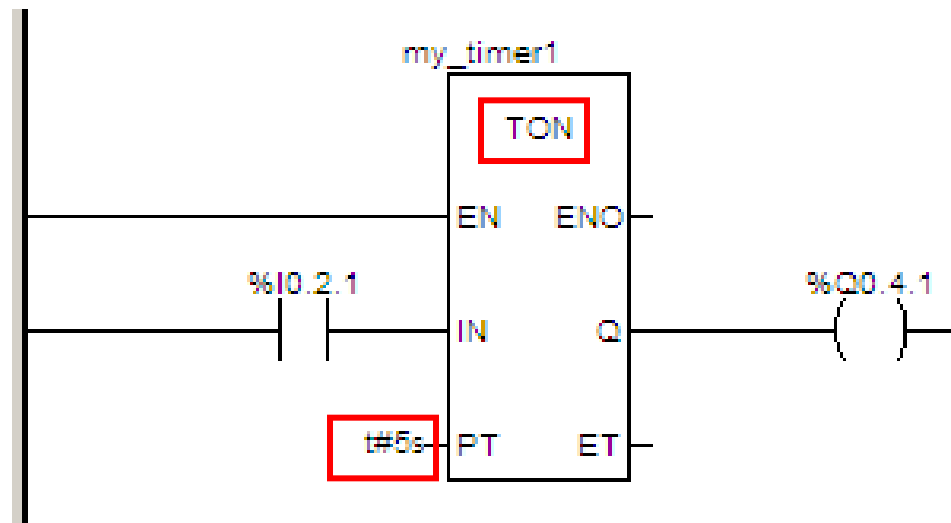
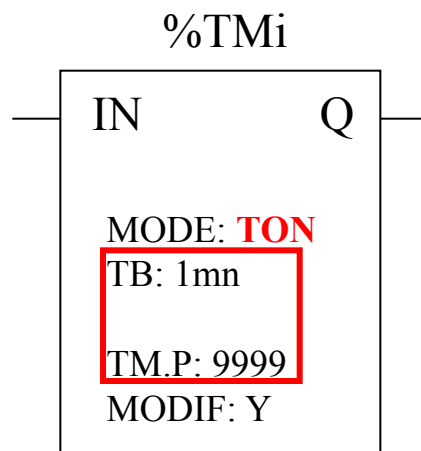

# Ladder diagram

## Timers in the Allen-Bradley PLC-5

### Two alternative representations

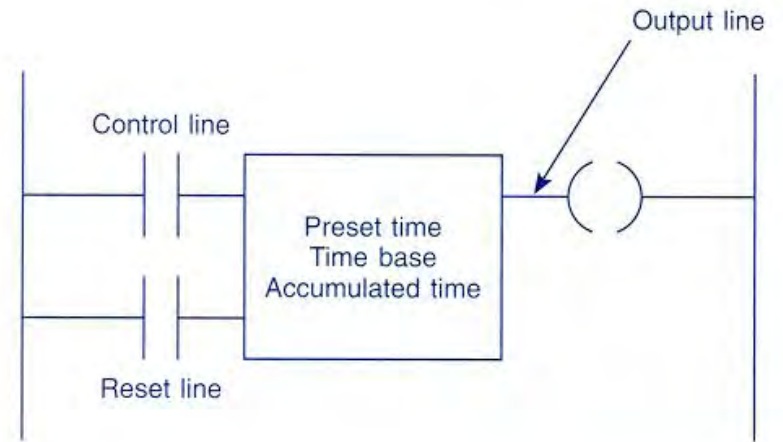
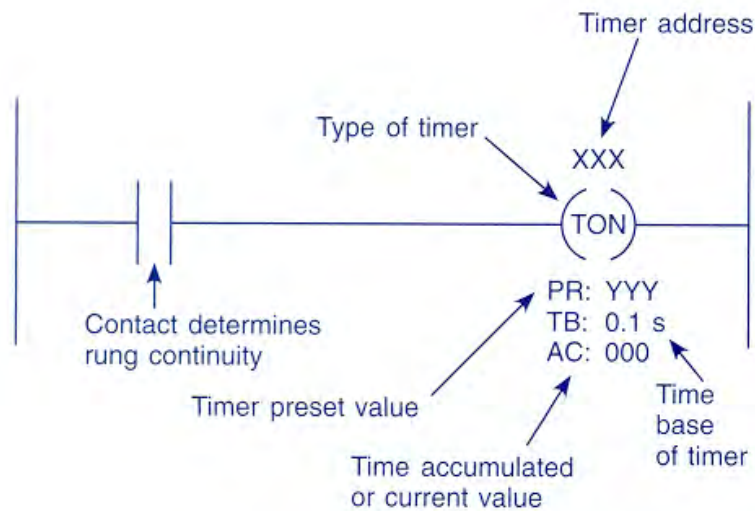
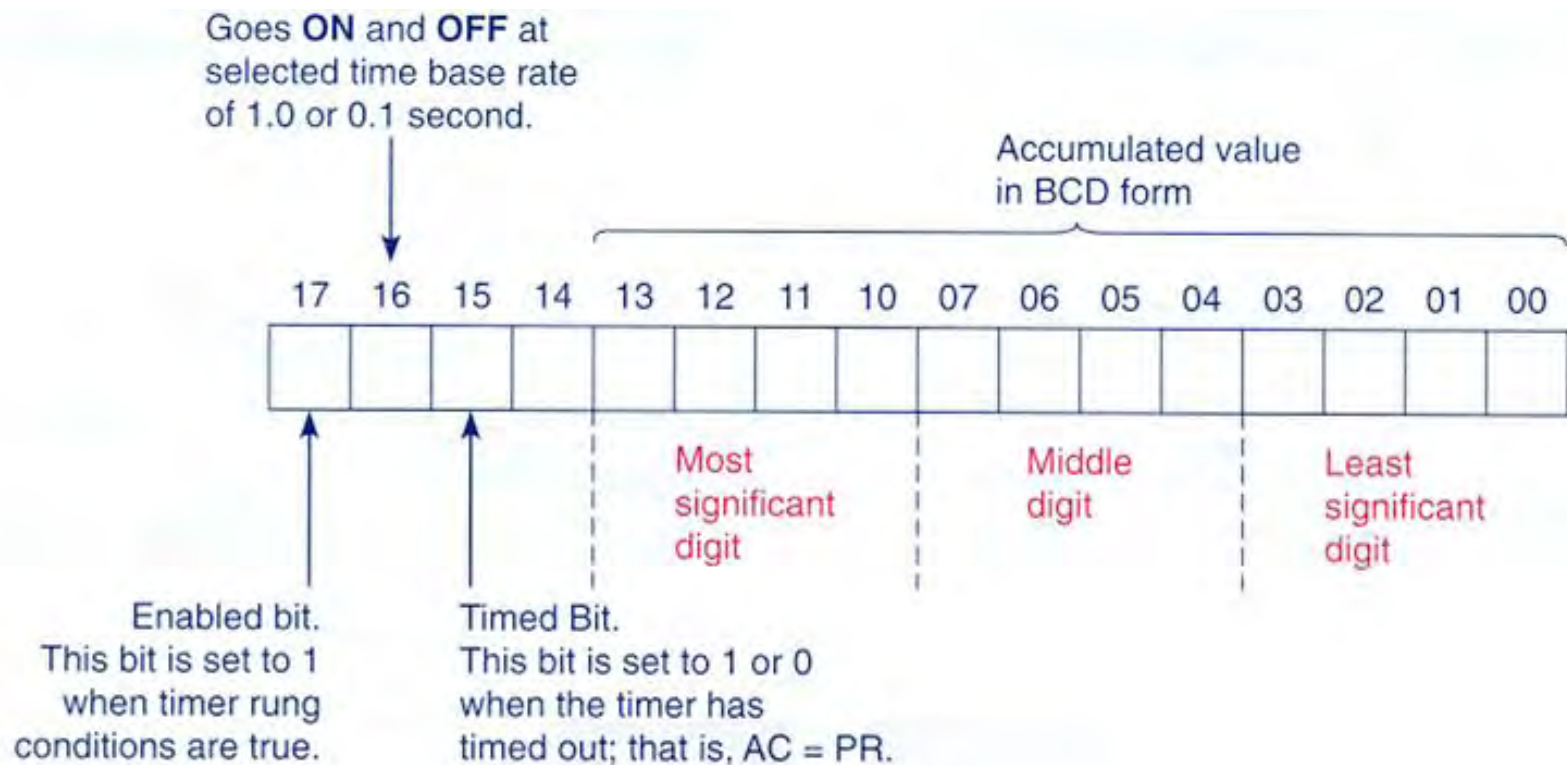

**Fig. 7-8**

Block-formatted timer instruction.

## Ladder diagram

### *Timers implementation in the Allen-Bradley PLC-5:*



# Ladder diagram

## Retentive Timers

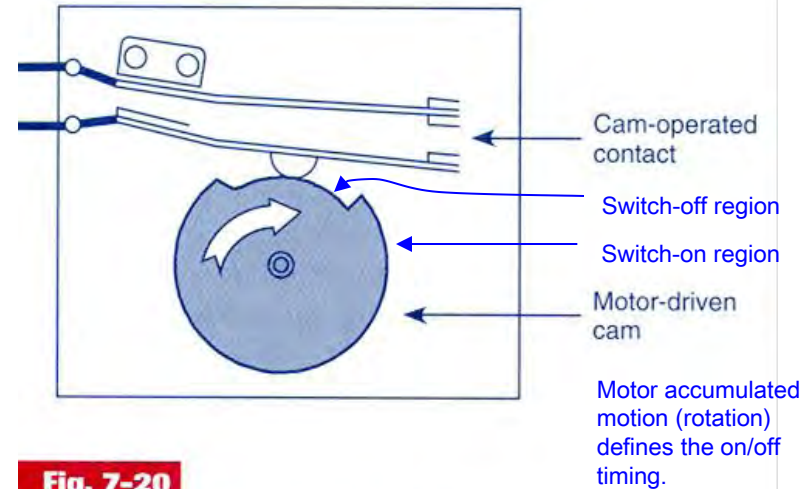

**Fig. 7-20**

Electromechanical retentive timer.

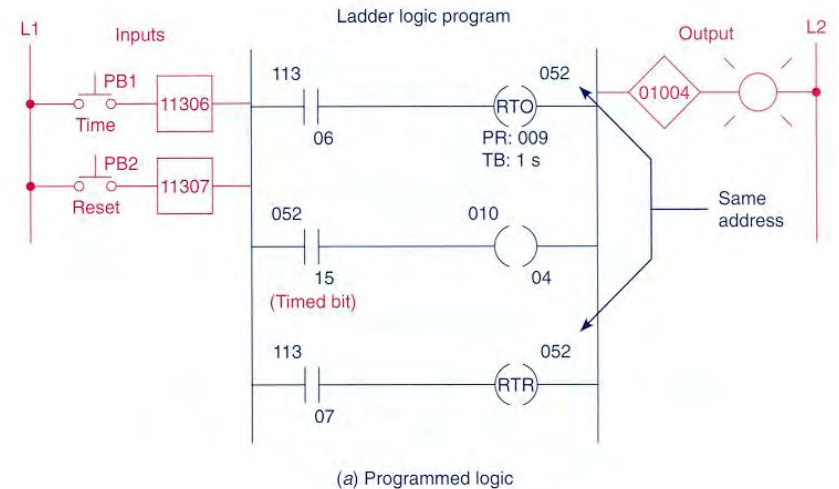
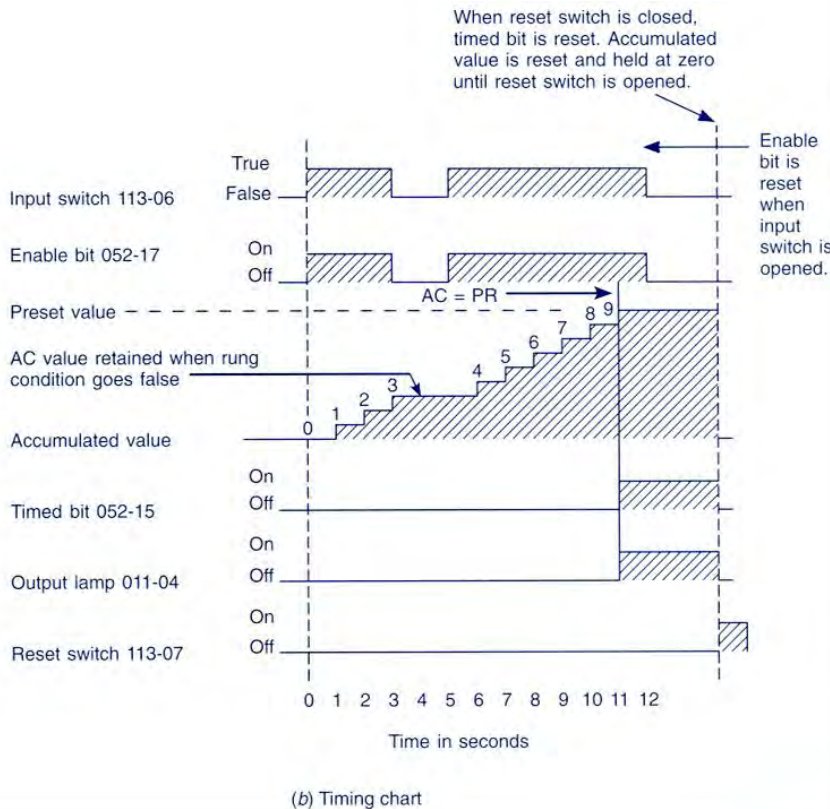

# Ladder diagram

## Example of *retentive timers*

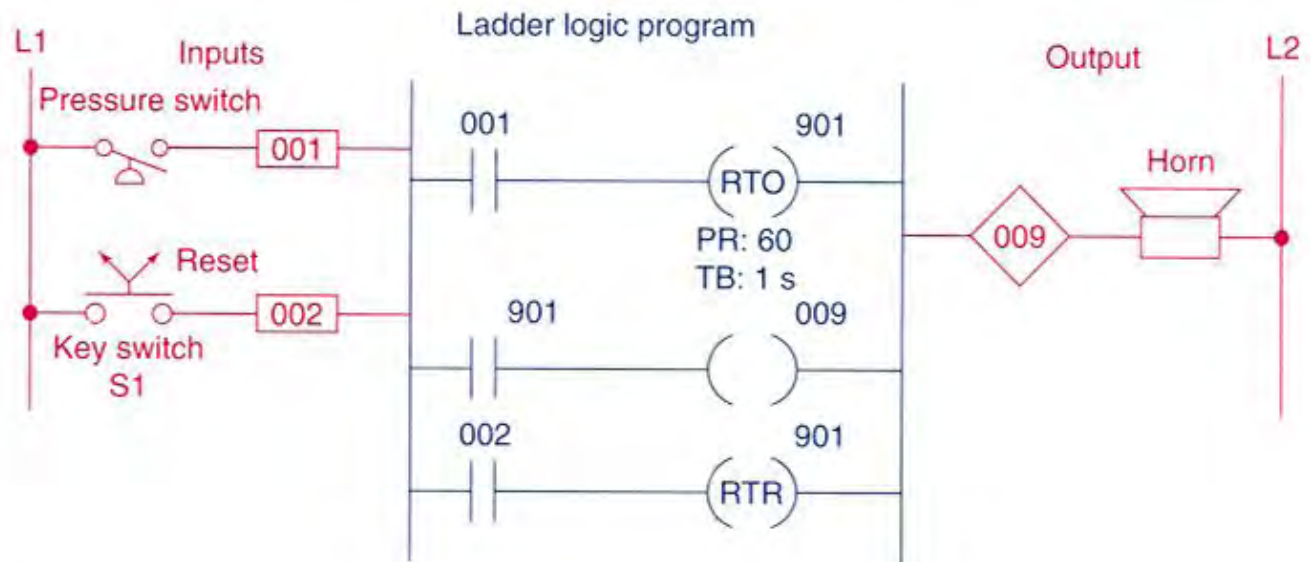

**Fig. 7-22**

Retentive on-delay alarm program.

## Ladder diagram

### *Retentive Timers*

**Animated demonstration:**

**(search on the Schneider PLC or discuss implementation)**

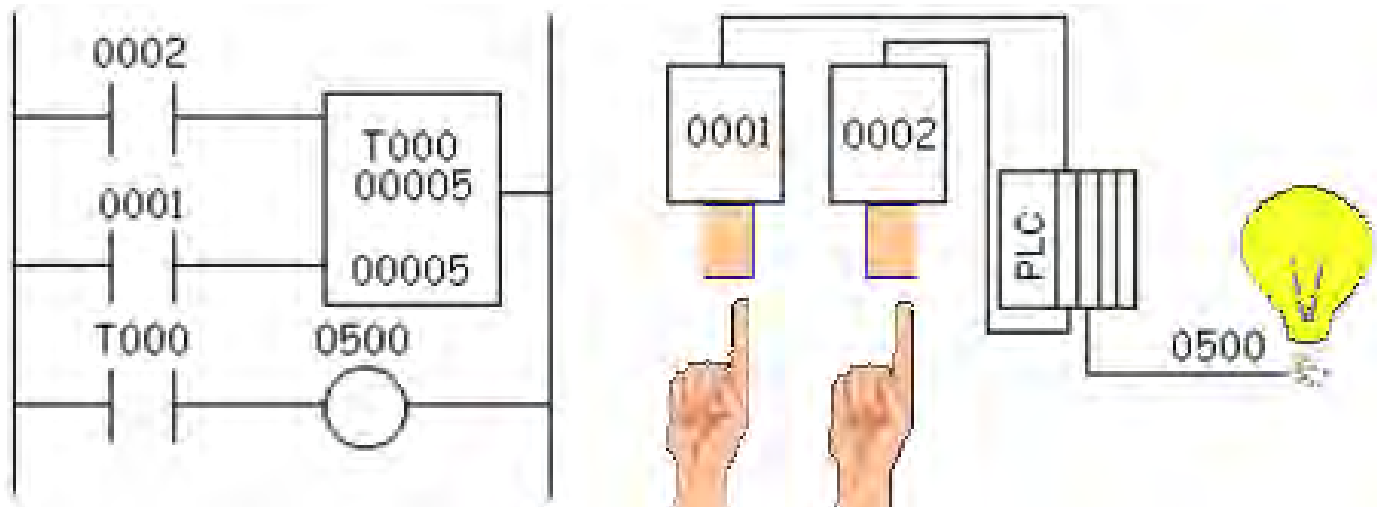

# Ladder diagram

## Example:

- SW ON to start operation
- Before motor starts, lubricate 10 s with oil.
- SW OFF to stop. (lubricate 15 s more).
- After 3 hours of pump operation, stop motor and signal with pilot light.
- Reset available after servicing.

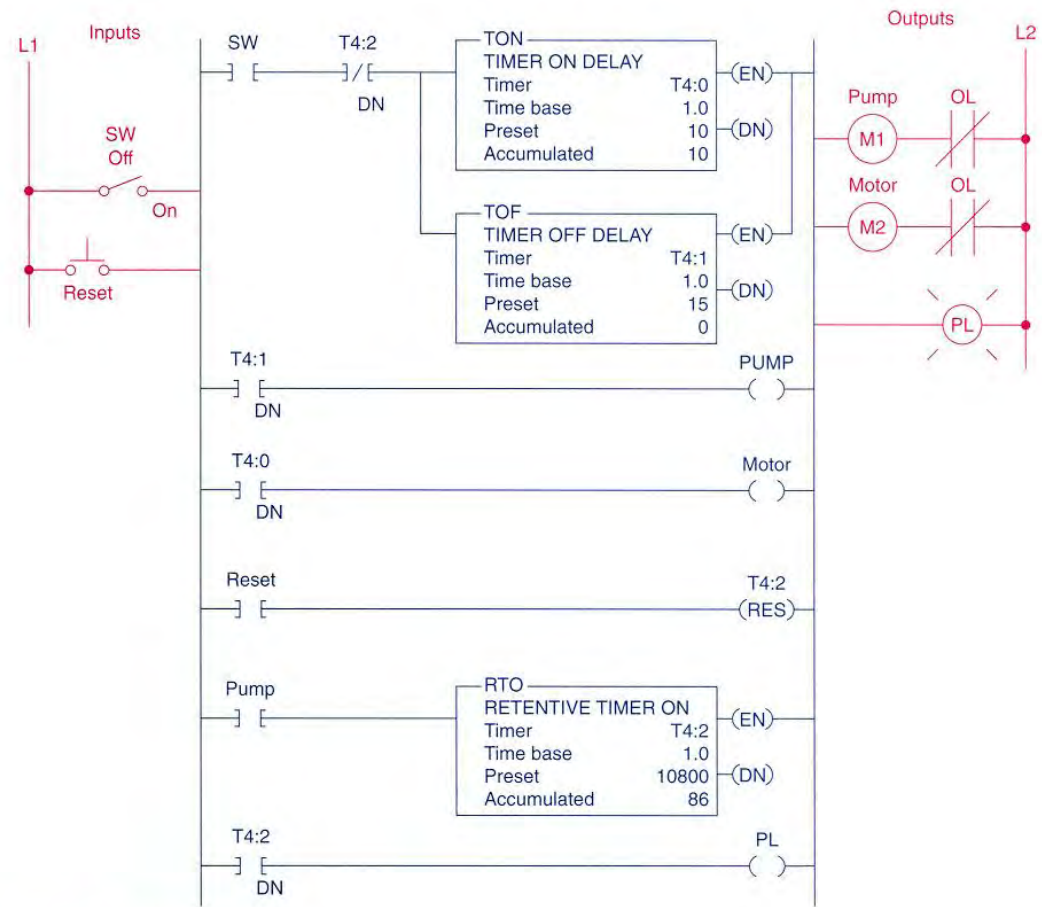

**Fig. 7-23**

Bearing lubrication program.



# Ladder diagram

## Cascaded Timers

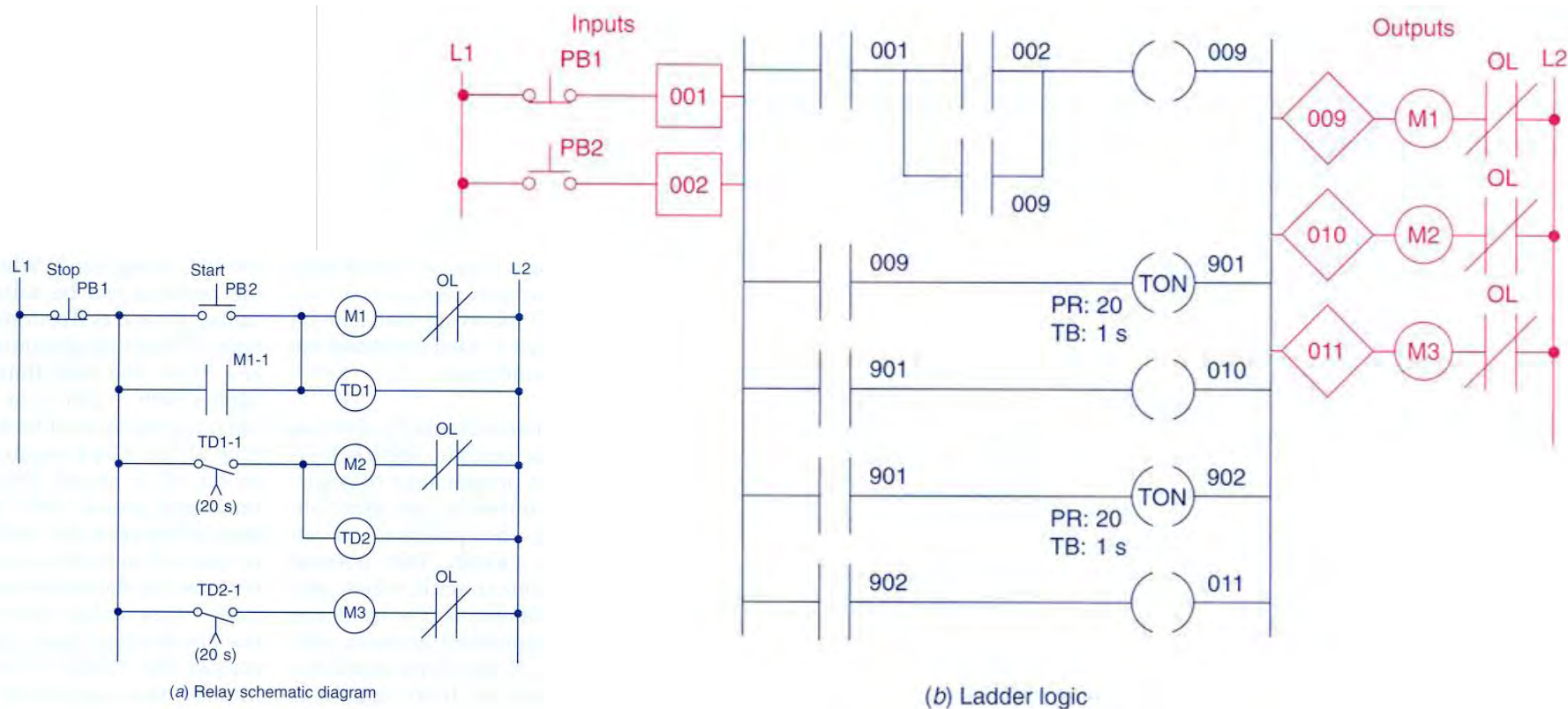
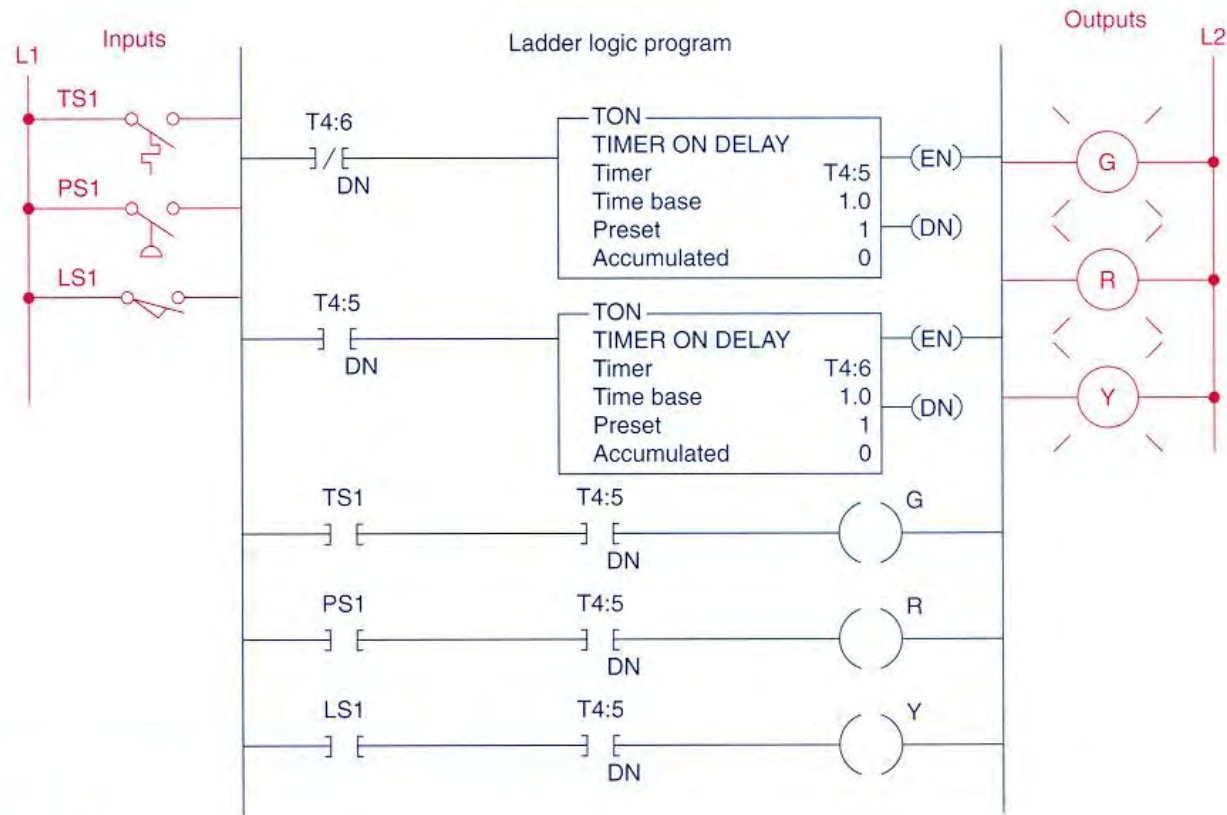

**Fig. 7-24**

Sequential time-delayed motor-starting circuit.

# Ladder diagram

## Cascaded Timers (bistable system)

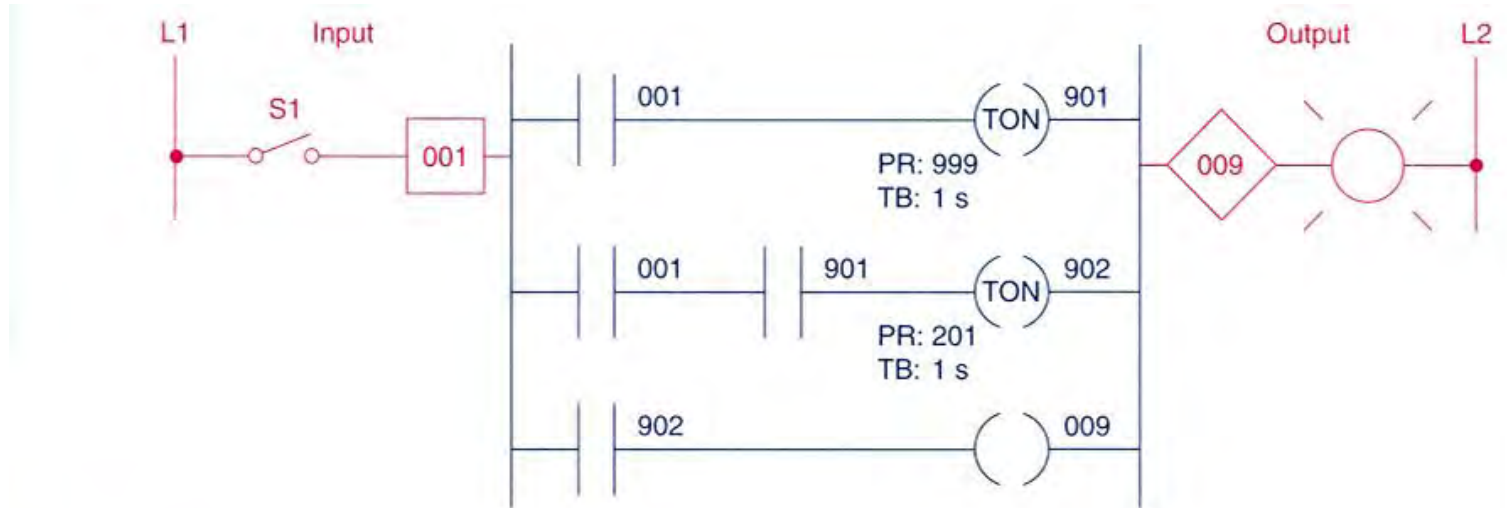

**Fig. 7-25**

Annunciator flasher program.

## Ladder diagram

### Timers for very long time intervals

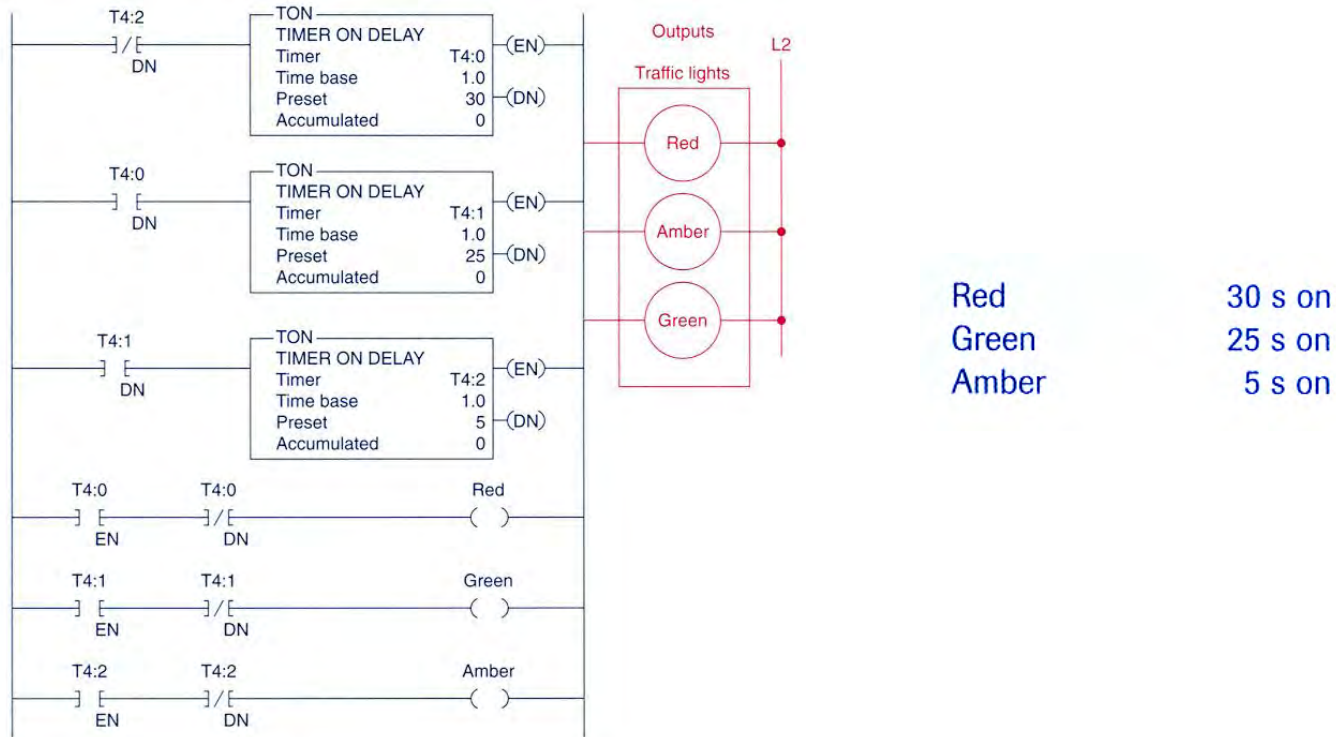

**Fig. 7-26**

Cascading of timers for longer time delays.

# Ladder diagram

## Example of a semaphore

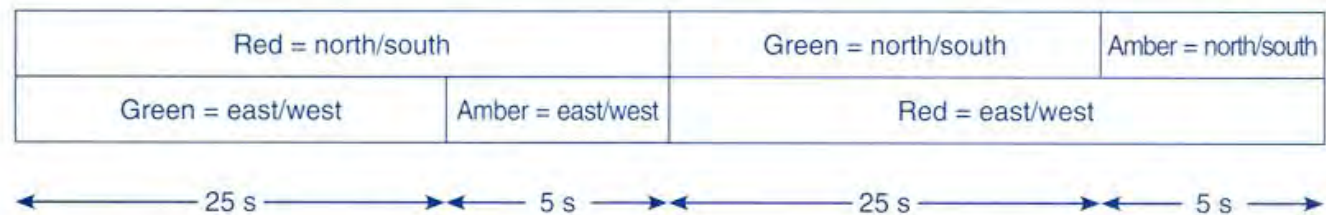

**Fig. 7-27**

Control of traffic lights in one direction.

## Example of a semaphore in both directions

Red	30 s on
Green	25 s on
Amber	5 s on



(b) Timing chart

**Fig. 7-28 (continued)**

Control of traffic lights in two directions.

# Example of a semaphore in both directions

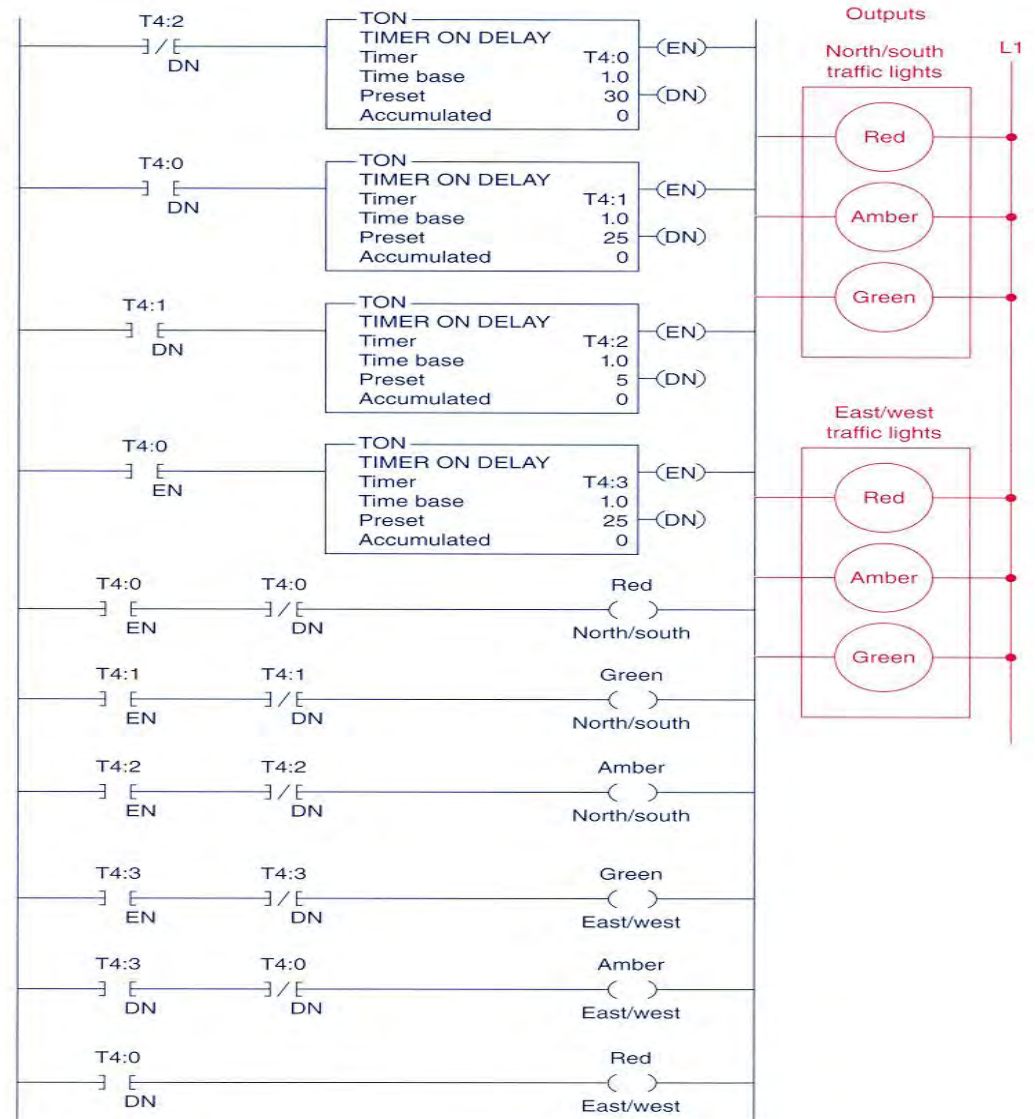

(a) Ladder logic

**Fig. 7-28**

Control of traffic lights in two directions.

# Ladder diagram

## Counters



Some applications...

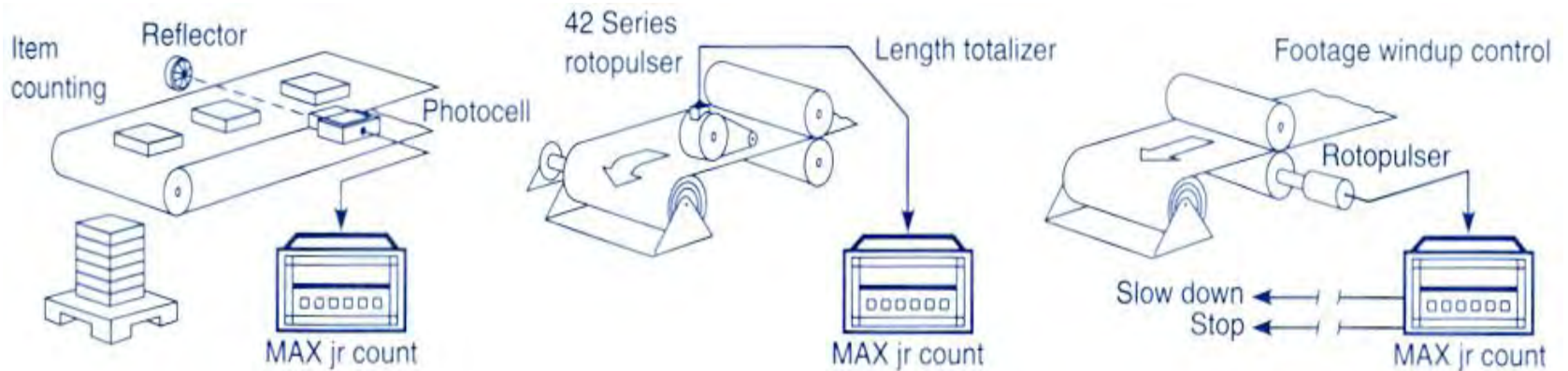
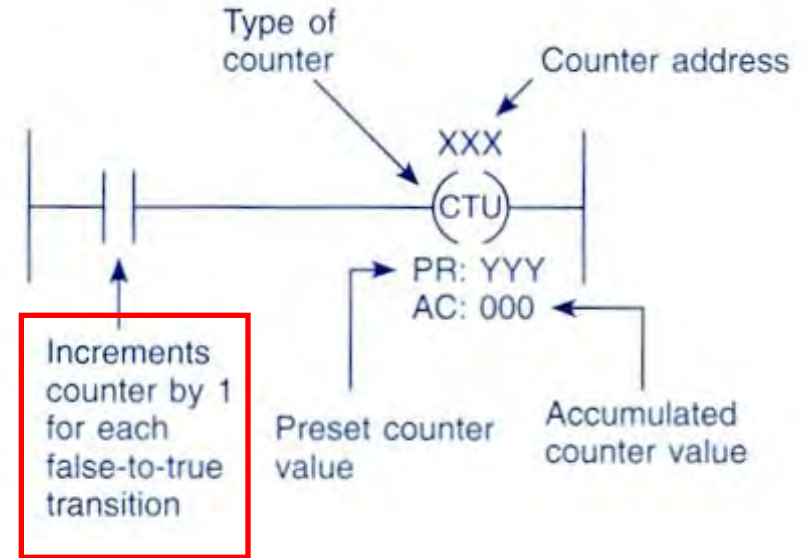

**Fig. 8-3**

Counter applications. (Courtesy of Dynapar Corporation, Gurnee, Illinois.)

# Ladder diagram

## Implementation of Counters in the PLC-5 of Allen-Bradley:



### Internal structure representation

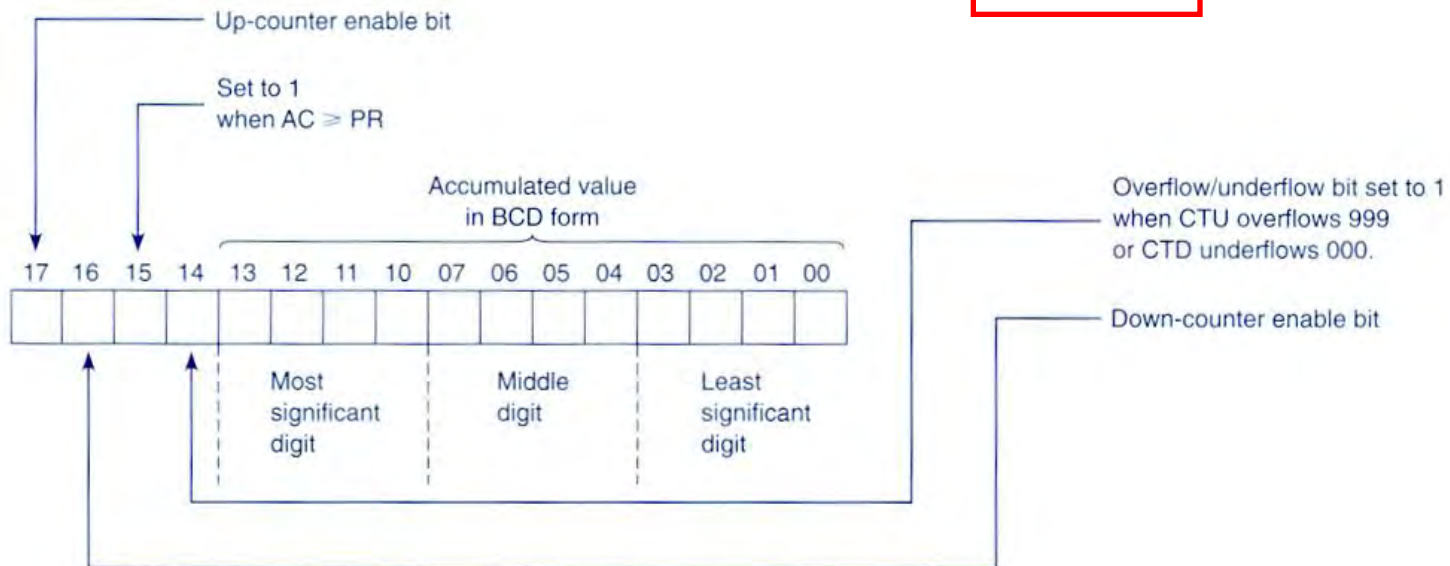

(b) Allen-Bradley PLC-2 timer accumulated value word (bit addressing is in octal)



# Ladder diagram

## Implementation of Counters in the PLC-5 of Allen-Bradley:

Two alternative representations:

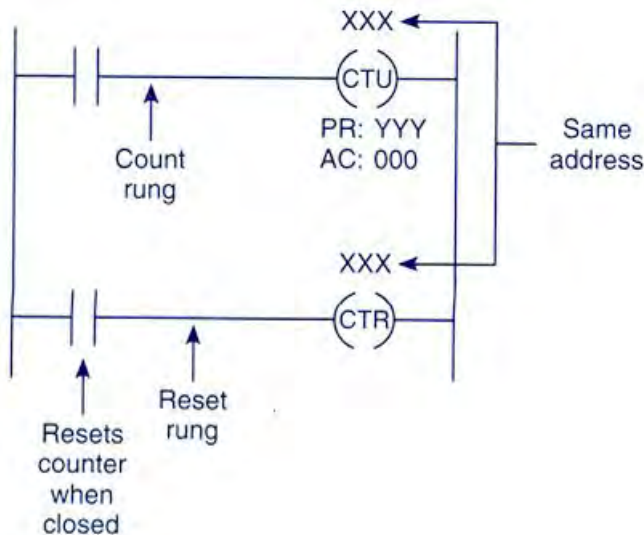

**Coil-formatted** counter and reset instructions

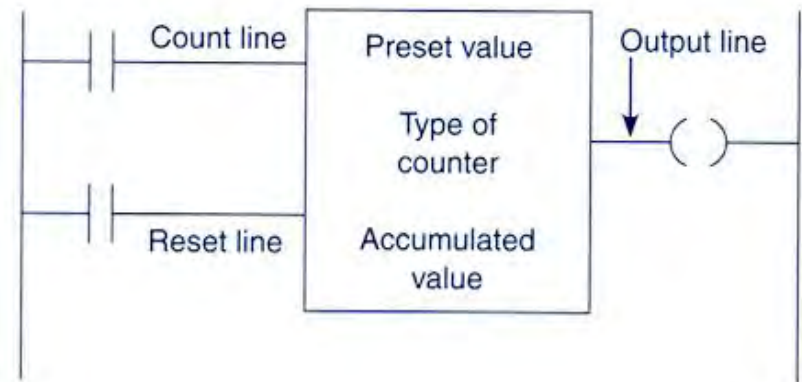

**Block-formatted** counter instruction

# Ladder diagram

## Up-counters

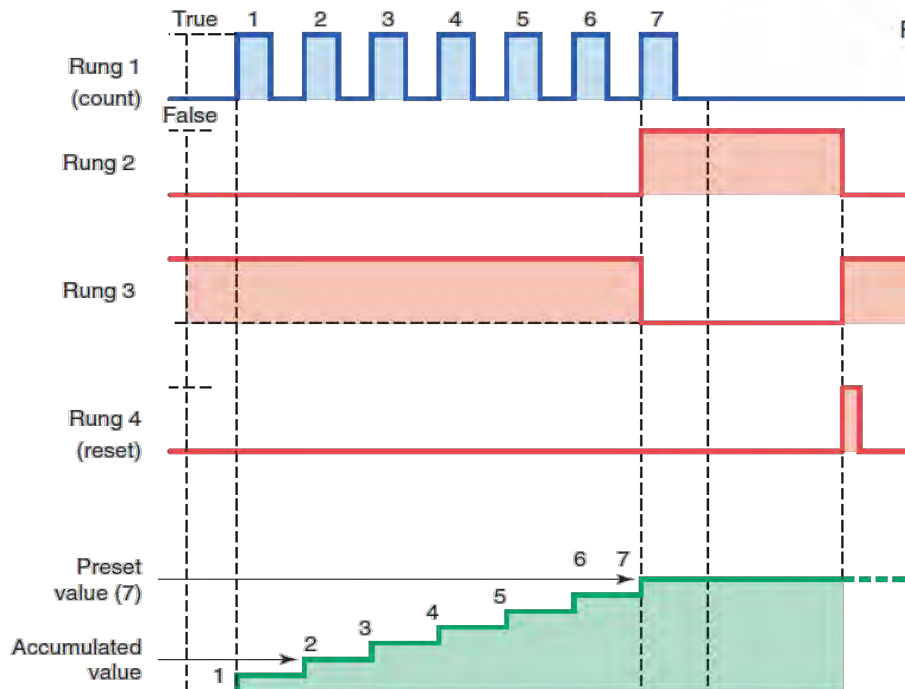
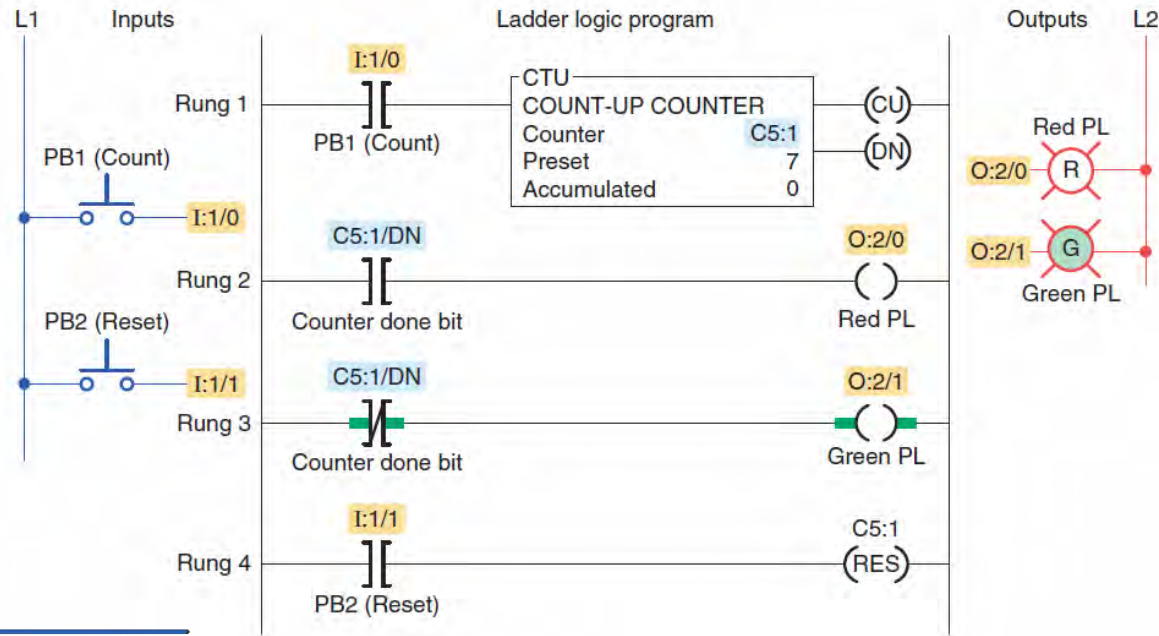

Usage of an **incremental up-counter** and the corresponding **temporal diagram:**

PB1 increments counting  
PB2 resets the counting

# Ladder diagram

## Example

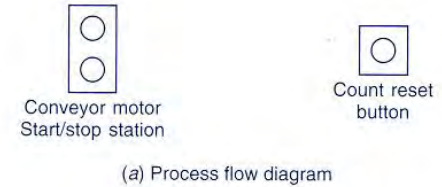
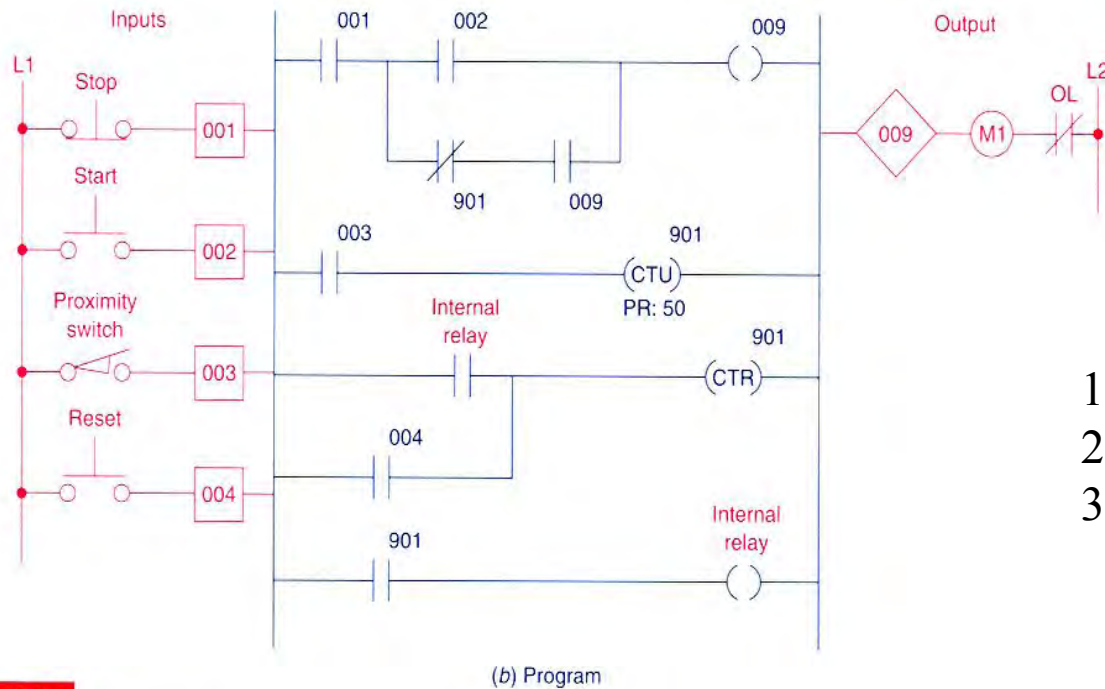
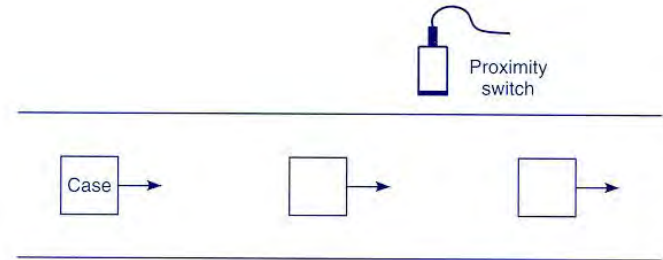

1. Start conveyor motor
2. Passing cases increment counter
3. After 50 cases, stop motor

**Fig. 8-13**  
Conveyor motor program.

# Ladder diagram

## Up/down-counters

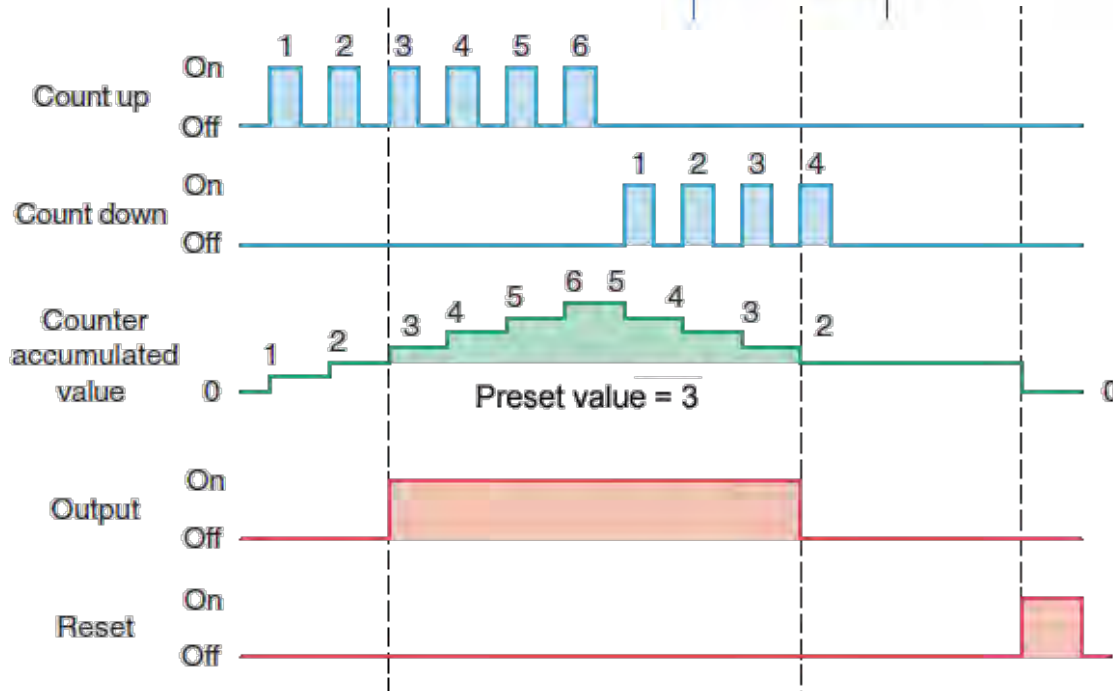
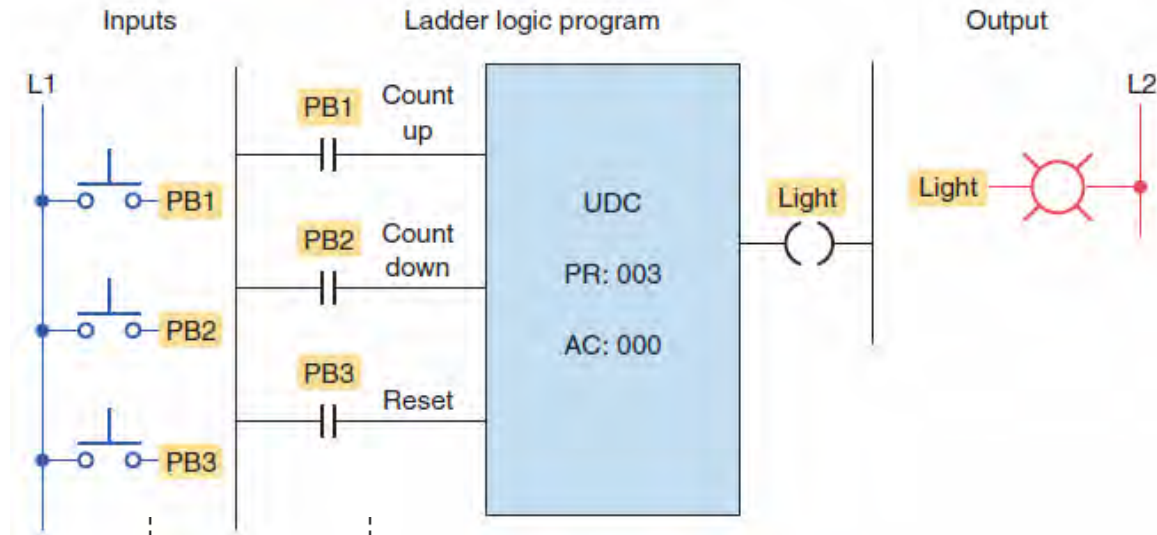

Usage of an **incremental up-down-counter** and the corresponding **temporal diagram**:

PB1 increments counting  
 PB2 decrements the counting  
 PB3 resets the counter

# Ladder diagram

## Up/down-counters

**Example:**

Finite parking garage

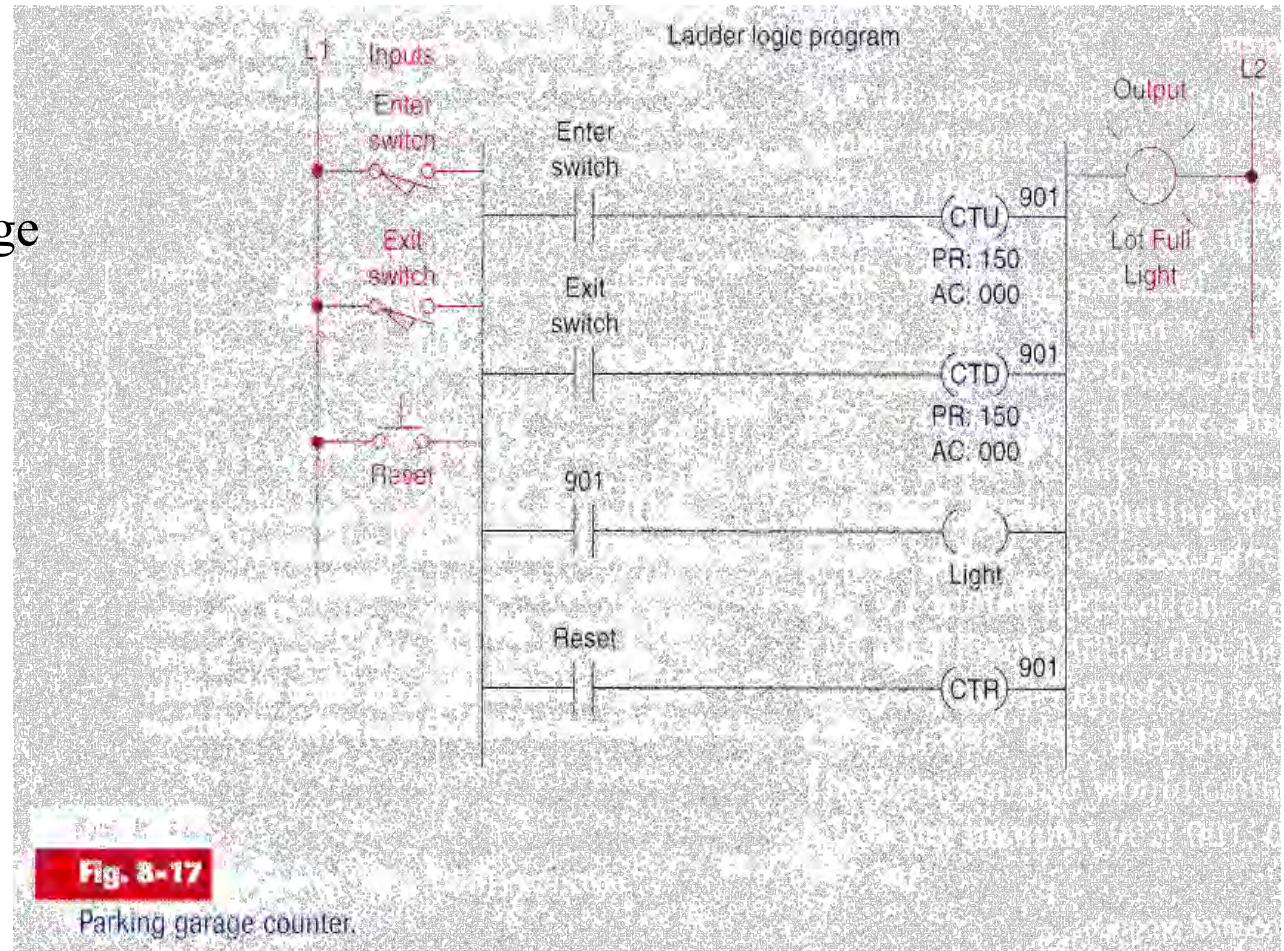

# Ladder diagram

## Cascaded Counters

Example:

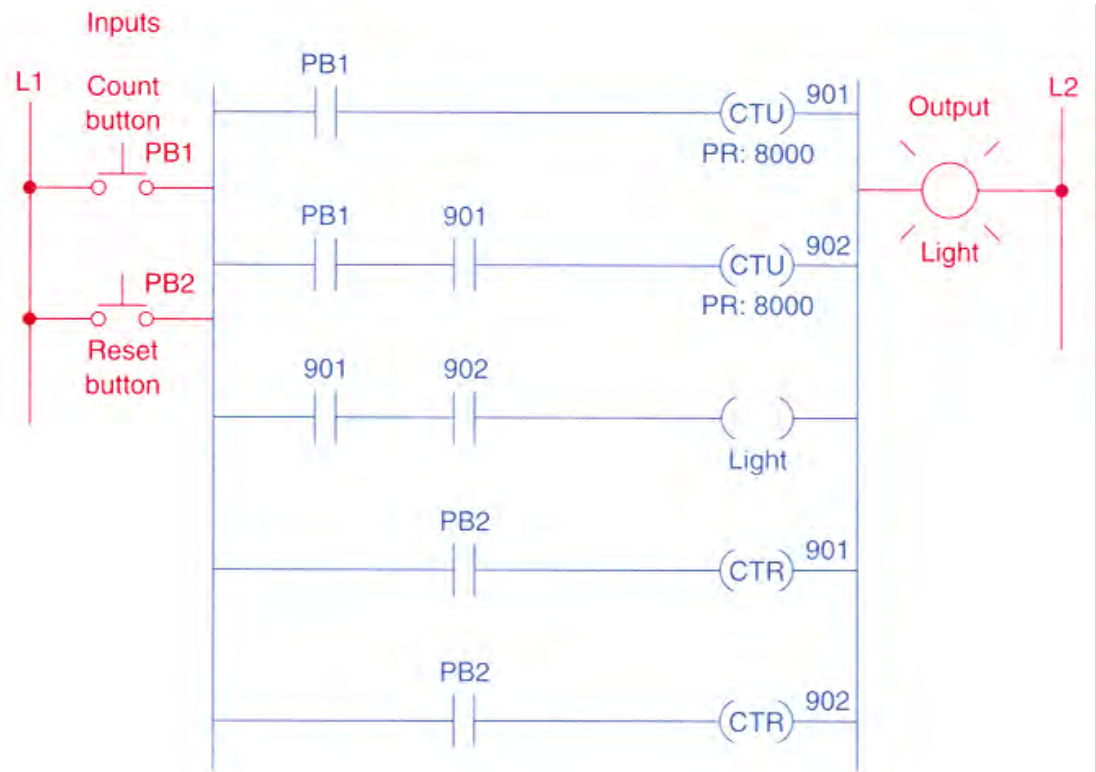

**Fig. 8-21**

Counting beyond the maximum count.

# Ladder diagram

## Cascaded Counters

Example:

24 hours clock

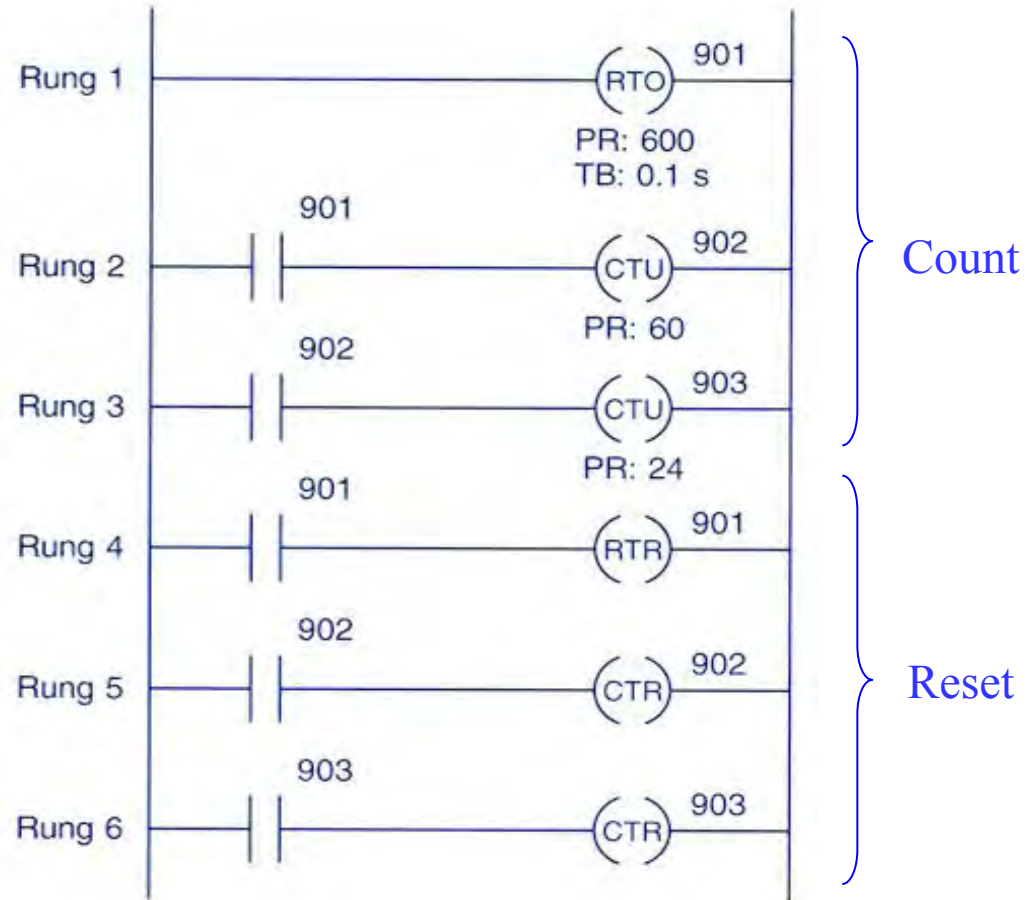

**Fig. 8-23**

A 24-h clock program.

# Ladder diagram

## Incremental Encoder

counter measures **rotation angle** or **rotation speed** (if divided by time)

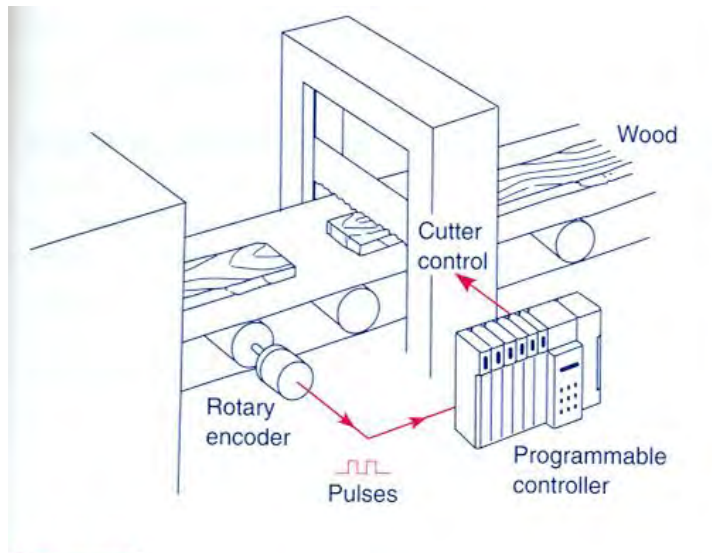

**Fig. 8-26**

Cutting objects to a specified size.

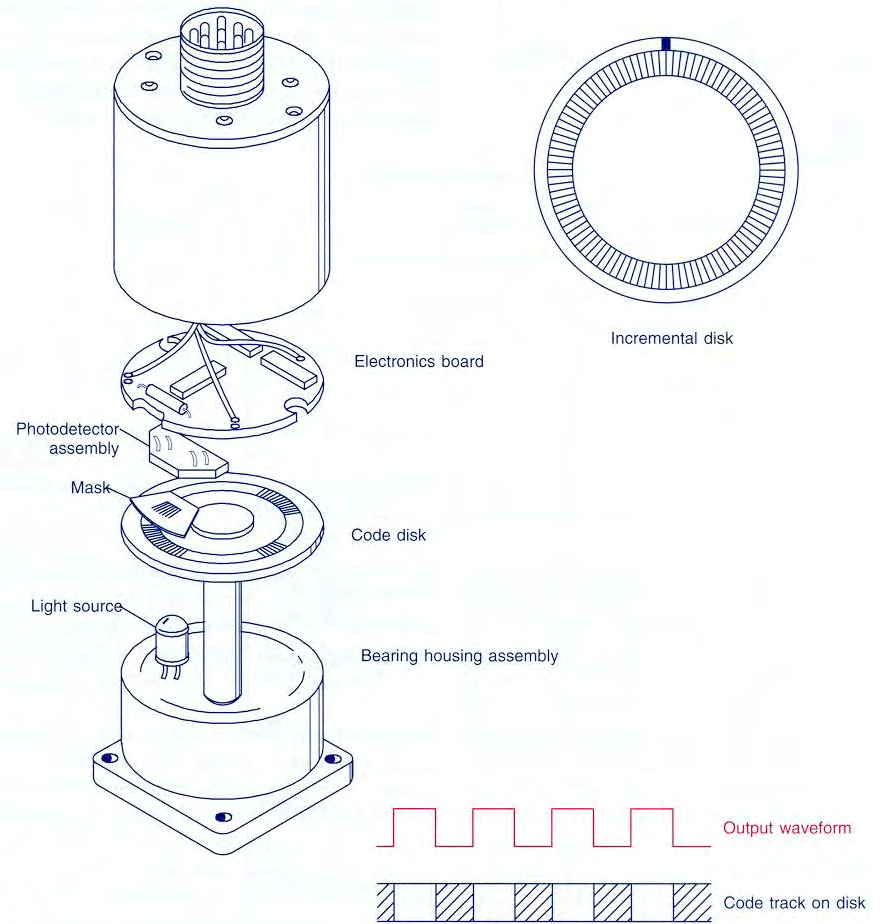

**Fig. 8-25**

Incremental encoder. (Courtesy of BEI Motion Systems Company.)



# Ladder diagram

## Incremental *Encoder*

**Example:**  
counter as a "length sensor"

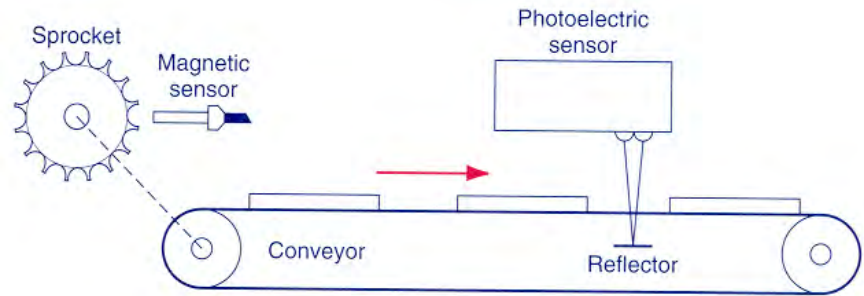

(a) Process

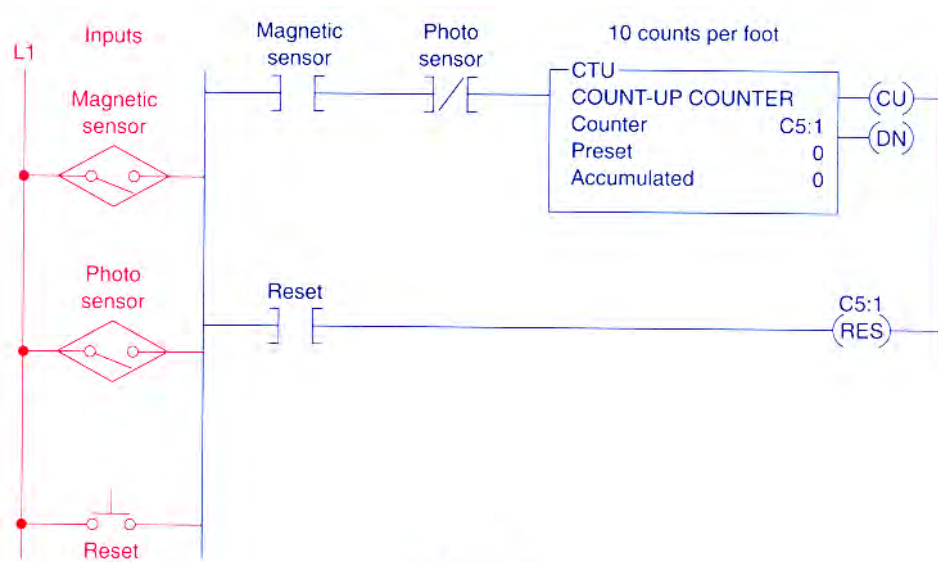

(b) Program

**Fig. 8-27**

Counter used for length measurement.

# Ladder diagram

## Counters in PL7

### Characteristics:

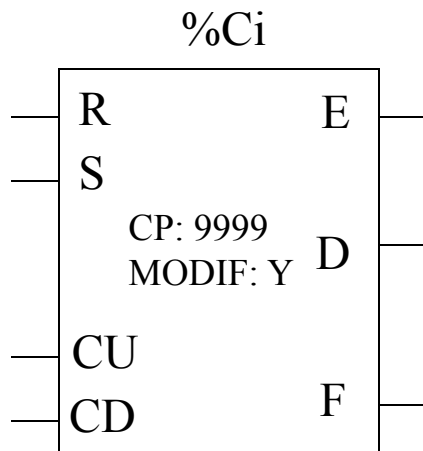

Identifier: %Ci	0..31 in the TSX37
Value progr.:	%Ci.P 0...9999 (def.)
Value Actual:	%Ci.V 0...Ci.P (only to be read)
Modifiable:	Y/N can be modified from the console
Inputs:	R Reset Ci.V=0 S Preset Ci.V=Ci.P CU <i>Count Up</i> CD <i>Count Down</i>
Outputs:	E Overrun %Ci.E=1 %Ci.V=0->9999 D Done %Ci.D=1 %Ci.V=Ci.P F Full %Ci.F=1 %Ci.V=9999->0

# Ladder diagram

## Counters in Unity Pro

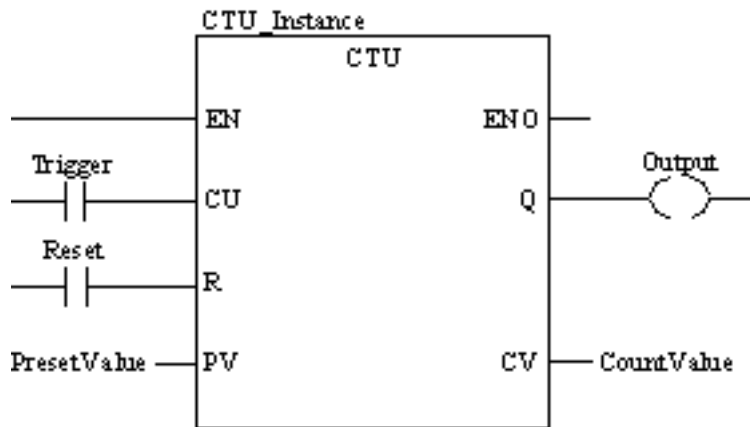

**CU "0" to "1"** => CV is incremented by 1

**CV ≥ PV** => Q:=1

**R=1** => CV:=0

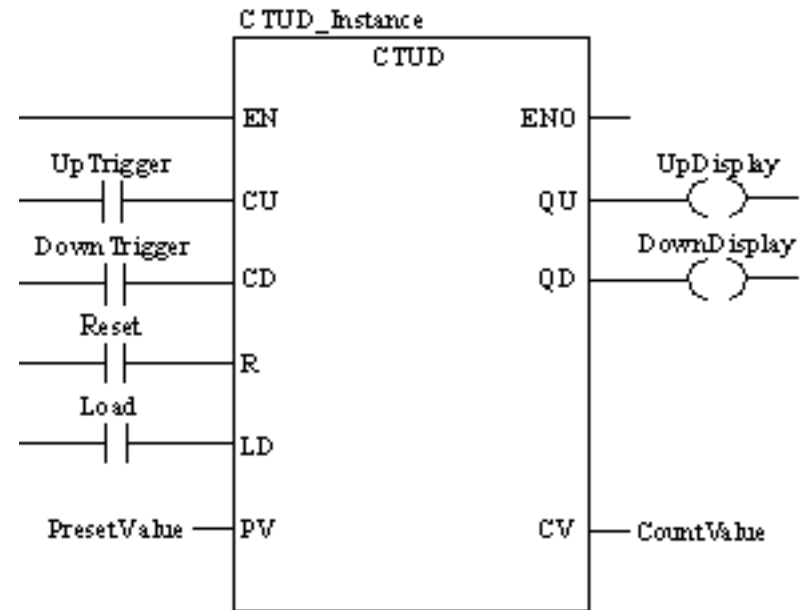

**CU "0" to "1"** => CV is incremented by 1

**CD "0" to "1"** => CV is decremented by 1

**CV ≥ PV** => QU:=1

**CV ≤ 0** => QD:=1

**R=1** => CV:=0    **LD=1** => CV:=PV

R has precedence over LD

*NOTE: counters are saturated such that no overflow occurs*

# Ladder diagram

## Numerical Processing

### Algebraic and Logic Functions

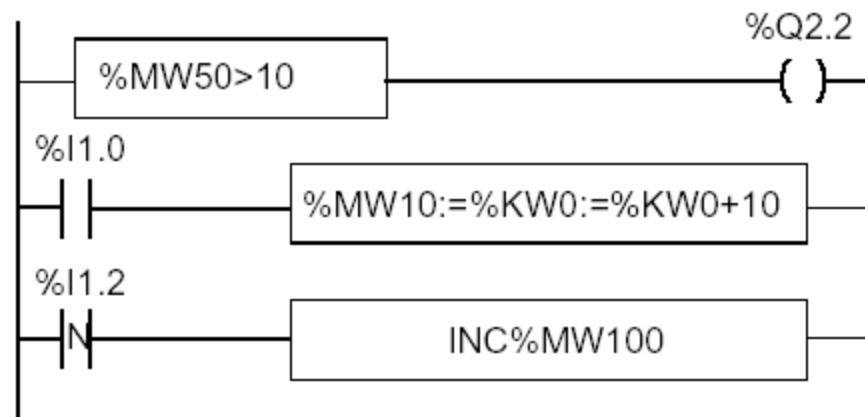

# Ladder diagram

## Numerical Processing

### Arithmetic Functions

<b>+</b>	addition of two operands	<b>SQRT</b>	square root of an operand
<b>-</b>	subtraction of two operands	<b>INC</b>	incrementation of an operand
<b>*</b>	multiplication of two operands	<b>DEC</b>	decrementation of an operand
<b>/</b>	division of two operands	<b>ABS</b>	absolute value of an operand
<b>REM</b>	remainder from the division of 2 operands		

#### Operands

Type	Operand 1 (Op1)	Operand 2 (Op2)
Indexable words	%MW	%MW,%KW,%Xi.T
Non-indexable words	%QW,%SW,%NW,%BLK	Imm.Val.,%IW,%QW,%SW,%NW,%BLK, Num.expr.
Indexable double words	%MD	%MD,%KD
Non-indexable double words	%QD,%SD	Imm.Val.,%ID,%QD,%SD, Numeric expr.

# Ladder diagram

## Numerical Processing

### Example:

#### Arithmetic functions

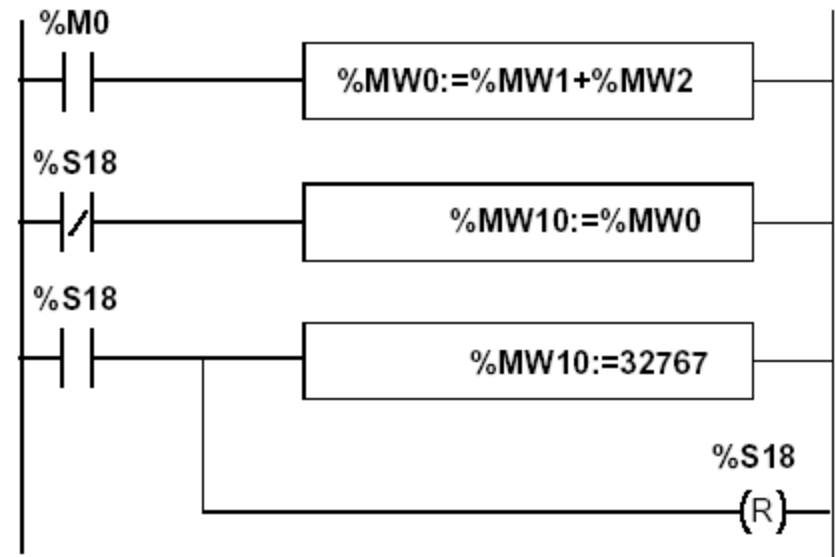
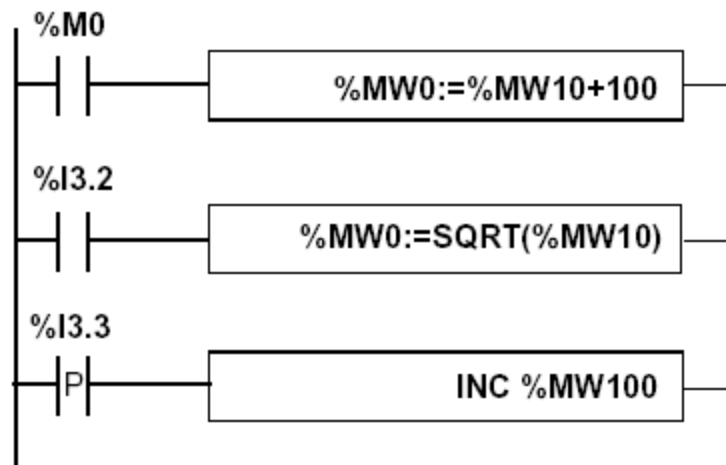

Use of a system variable:

%S18 – flag de overflow

## Ladder diagram

### Numerical Processing

#### Logic Functions

<b>AND</b>	AND (bit by bit) between two operands
<b>OR</b>	logical OR (bit by bit) between two operands
<b>XOR</b>	exclusive OR (bit by bit) between two operands
<b>NOT</b>	logical complement (bit by bit) of an operand

Comparison instructions are used to compare two operands.

- >: tests whether operand 1 is greater than operand 2,
- >=: tests whether operand 1 is greater than or equal to operand 2,
- <: tests whether operand 1 is less than operand 2,
- <=: tests whether operand 1 is less than or equal to operand 2,
- =: tests whether operand 1 is different from operand 2.

#### Operands

Type	Operands 1 and 2 (Op1 and Op2)
Indexable words	%MW,%KW,%Xi.T
Non-indexable words	Imm.val.,%IW,%QW,%SW,%NW,%BLK, Numeric Expr.
Indexable double words	%MD,%KD
Non-indexable double words	Imm.val.,%ID,%QD,%SD,Numeric expr.

# Ladder diagram

## Numerical Processing

### Example:

Logic functions

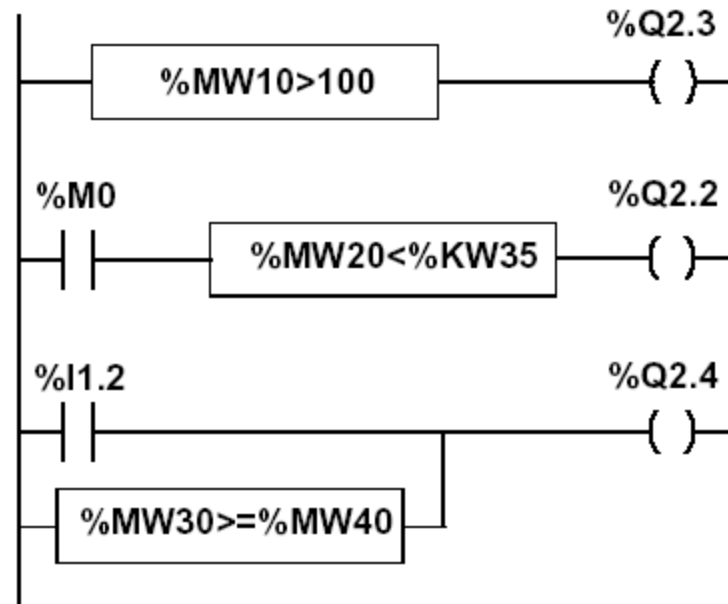



## Ladder diagram

### Numerical Processing

#### Priorities on the execution of the operations

Rank	Instruction
1	Instruction to an operand
2	*,/,REM
3	+,-
4	<,>,<=,>=
5	=,<>
6	AND
7	XOR
8	OR

# Ladder diagram

## Structures for Control of Flux

### Subroutines

### Call and Return

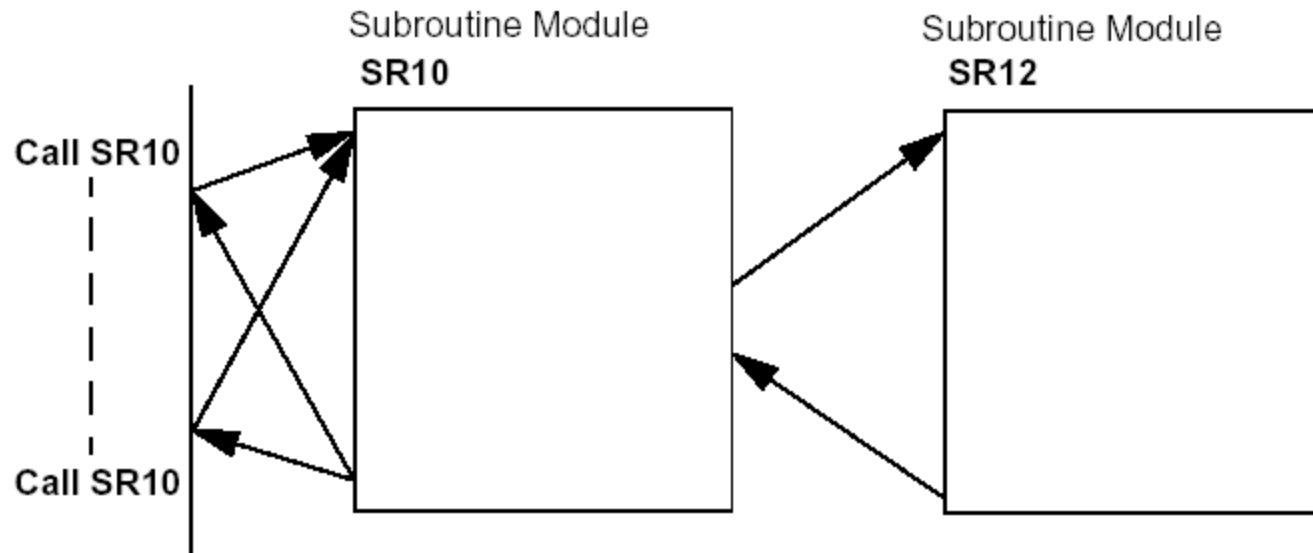
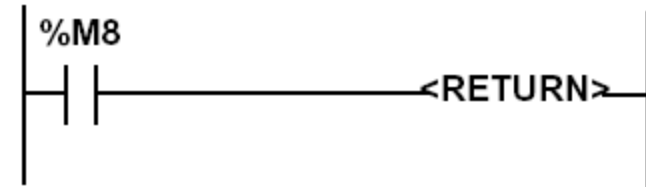
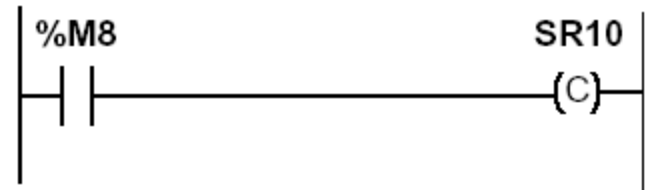

## Ladder diagram

### Structures for Control of Flux

#### JUMP instructions:

##### Conditional and unconditional

---

Jump instructions are used to go to a programming line with an %Li label address:

- **JMP**: unconditional program jump
  - **JMPC**: program jump if the instruction's Boolean result from the previous test is set at 1
  - **JMPCN**: program jump if the instruction's Boolean result from the previous test is set at 0. %Li is the label of the line to which the jump has been made (address i from 1 to 999 with maximum 256 labels)
-

## Ladder diagram

### Structures for Control of Flux

#### Example:

Use of jump instructions

#### Attention to:

- **INFINITE LOOPS ...**
- **It is not a good style of programming!...**
- **Does not improve the legibility of the proposed solution.**

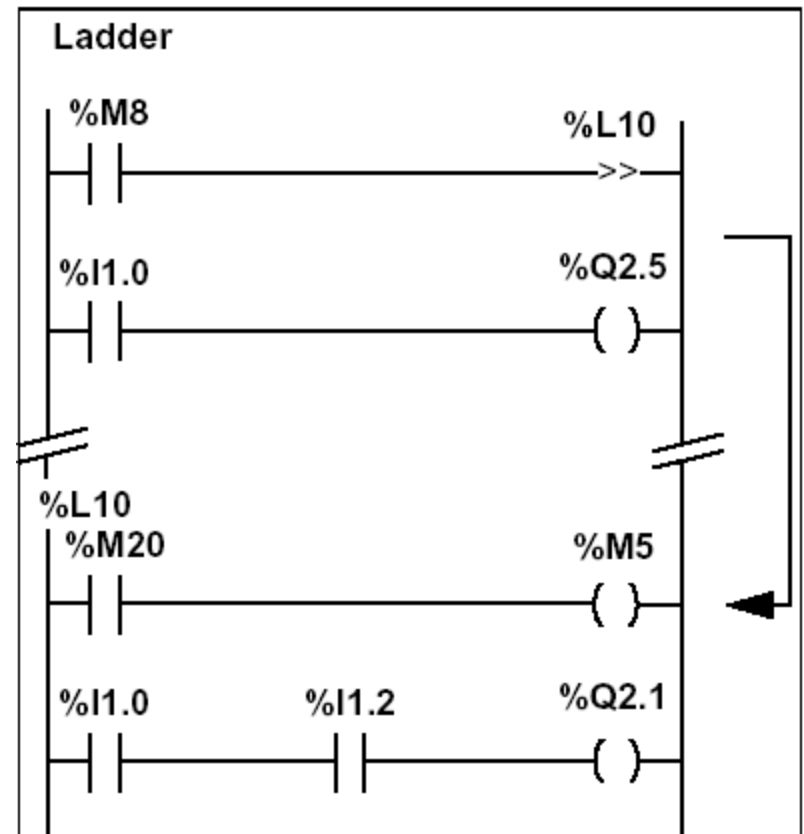

## Ladder diagram

### Structures for Control of Flux

#### Halt

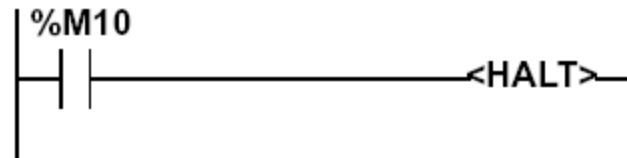

Stops all processes!

#### Events masking

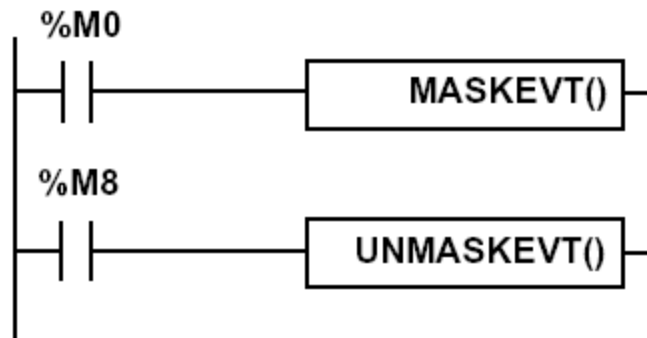

## Ladder diagram

**There are other advanced instructions (see manual)**

- **Monostable**
- **Registers of 256 words (LIFO ou FIFO)**
- ***DRUMs***
- **Comparators**
- ***Shift-registers***
- **...**
- **Functions to manipulate *floats***
- **Functions to convert bases and types**

# Ladder diagram

## Numerical Tables

Type	Format	Maximum address	Size	Write access
Internal words	Simple length	%MWi:L	i+L<=Nmax (1)	Yes
	Double length	%MWDi:L	i+L<=Nmax-1 (1)	Yes
	Floating point	%MFi:L	i+L<=Nmax-1 (1)	Yes
Constant words	Single length	%KWi:L	i+L<=Nmax (1)	No
	Double length	%KWDi:L	i+L<=Nmax-1 (1)	No
	Floating point	%KFi:L	i+L<=Nmax-1 (1)	No
System word	Single length	%SW50:4 (2)	-	Yes

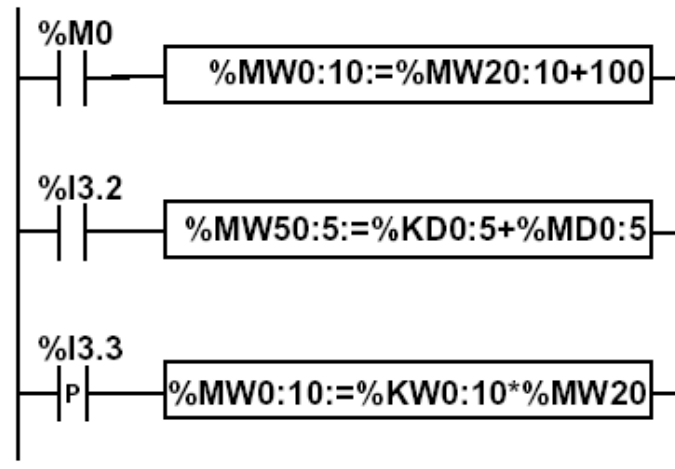

# Ladder diagram

## System information: system bits

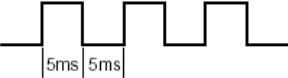
Bit	Function	Description	Initial state	TSX37	TSX57
%S0	Cold start	Normally on 0, this bit is set on 1 by: <ul style="list-style-type: none"> <li>● loss of data on power restart (battery fault),</li> <li>● the user program,</li> <li>● the terminal,</li> <li>● cartridge uploading,</li> <li>● pressing on the RESET button.</li> </ul> This bit goes to 1 during the first complete cycle. It is reset to 0 before the following cycle. (Operation)	0	YES	YES
%S1	Warm restart	Normally on 0, this bit is set on 1 by: <ul style="list-style-type: none"> <li>● power restart with data save,</li> <li>● the user program,</li> <li>● the terminal.</li> </ul> It is reset to 0 by the system at the end of the first complete cycle and before output is updated. (Operation)	0	YES	YES
%S4	Time base 10ms	An internal timer regulates the change in status of this bit. It is asynchronous in relation to the PLC cycle. Graph : 	-	YES	YES
%S5	Time base 100 ms	Idem %S4	-	YES	YES
%S6	Time base 1 s	Idem %S4	-	YES	YES
%S7	Time base 1 mn	Idem %S4	-	YES	YES

**See manual  
for the remaining  
100 bits generated...**



# Ladder diagram

## System information: system *words*

Words	Function	Description	Management
%SW0	Master task scanning period	The user program or the terminal modify the duration of the master task defined in configuration. The duration is expressed in ms (1.255 ms) %SW0=0 in cyclic operation. On a cold restart: it takes on the value defined by the configuration.	User
%SW1	Fast task scanning period	The user program or the terminal modify the duration of the fast task as defined in configuration. The duration is expressed in ms (1.255 ms) On a cold restart: it takes on the value defined by the configuration.	User
%SW8	Acquisition of task input monitoring	Normally on 0, this bit can be set on 1 or 0 by the program or the terminal. It inhibits the input acquisition phase of each task. <ul style="list-style-type: none"> <li>● %SW8:X0 =1 assigned to MAST task: outputs linked to this task are no longer guided.</li> <li>● %SW8:X1 =1 assigned to FAST task: outputs linked to this task are no longer guided.</li> </ul>	User
%SW9	Monitoring of task output update	Normally on 0, this bit can be set on 1 or 0 by the program or the terminal. Inhibits the output updating phase of each task. <ul style="list-style-type: none"> <li>● %SW9:X0 =1 assigned to MAST task: outputs linked to this task are no longer guided.</li> <li>● %SW9:X1 =1 assigned to FAST task: outputs linked to this task are no longer guided.</li> </ul>	User
%SW10	First cycle after cold start	If the bit for the current task is on 0, this indicates that the first cycle is being carried out after a cold start. <ul style="list-style-type: none"> <li>● %SW10:X0: is assigned to the MAST Master task</li> <li>● %SW10:X1: is assigned to the FAST fast task</li> </ul>	System
%SW11	Watchdog duration	Reads the duration of the watchdog as set in configuration. It is expressed in ms (10...500 ms).	System

See manual  
for the remaining  
140 words generated...

# Ladder diagram      Software Organization

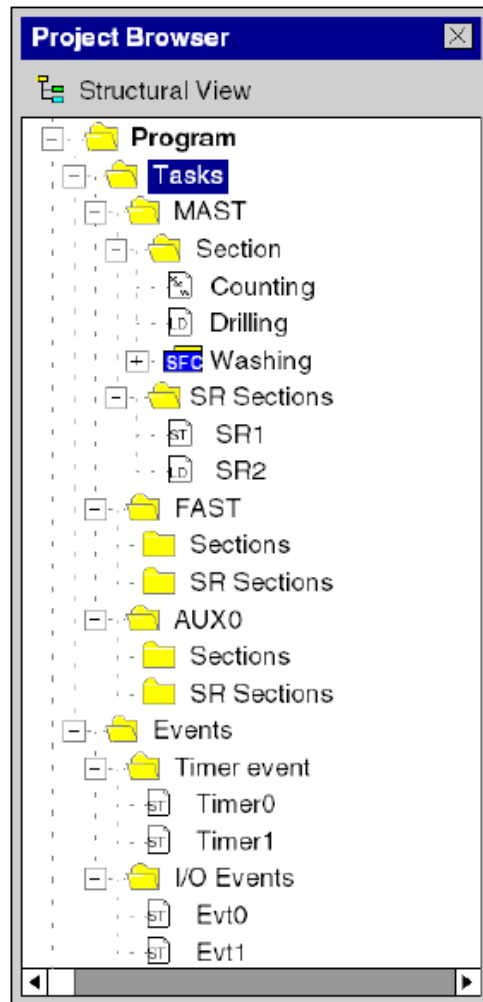

A program can be built from:

Tasks, that are executed cyclically or periodically.

Tasks **MAST** / **FAST** / **AUX** are built from:

Sections

Subroutines

Event processing, that is carried out before all other tasks.

Event processing is built from:

Sections for processing time controlled events

Sections for processing hardware controlled events

*Unity - Project Browser*

# Ladder diagram      Software Organization

**MAST** – Master Task Program

Composed by **sections**

Execution **Cyclic** or **Periodic**

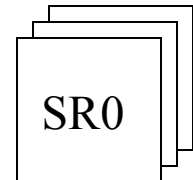
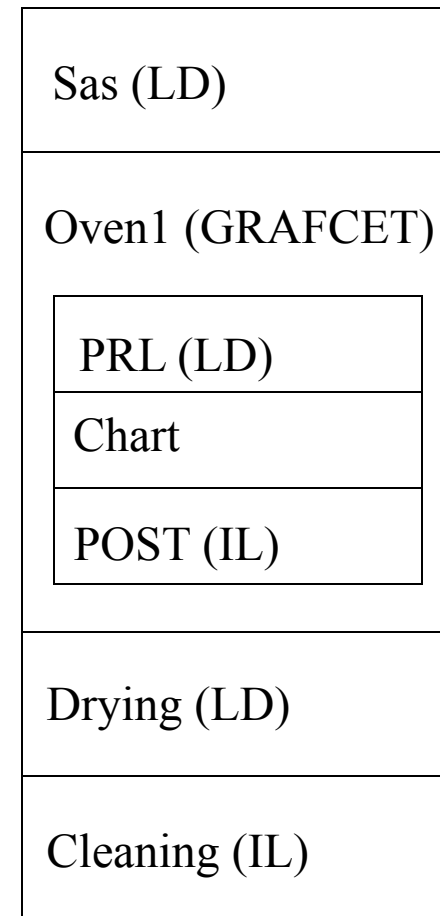
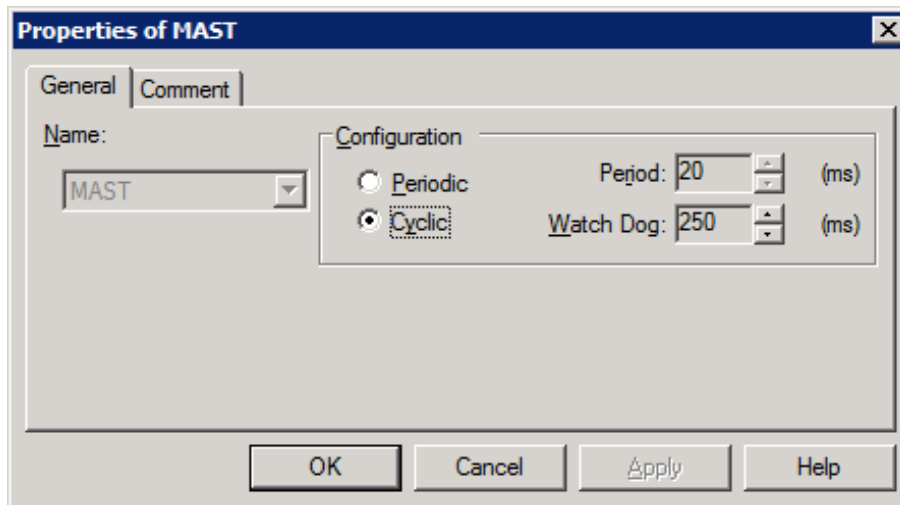

## Ladder diagram      Software Organization

**FAST – Fast Task Program**

**Priority greater than MAST**

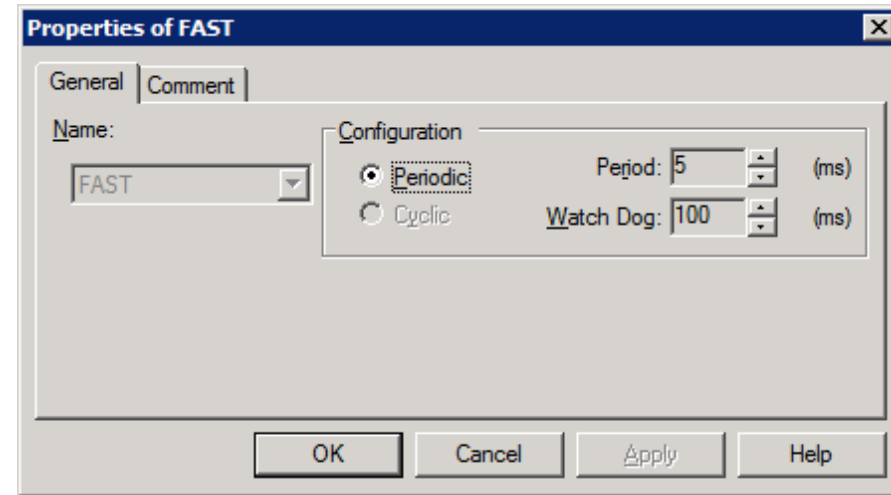

- Executed Periodically (1-255ms)
- Verified by a *Watchdog*, impacts on %S11
- %S31 *Enables* or *disables* a FAST
- %S33 gives the execution time for FAST

## Ladder diagram      Software Organization

**Event Processes** – Processes that can react to external changes  
(16 in the Micro 3722 EV0 to EV15)

**Priority greater than MAST and FAST!**

### Event Generators

- Inputs 0 to 3 in module 1, given transitions
- Counters
- Upon telegrams reception
- %S38 *Enables* or *disables* event processes

(also with MASKEVT() or UNMASKEVT())

## Ladder diagram Development tools

Each PLC has limitations in terms of connections

### Example:

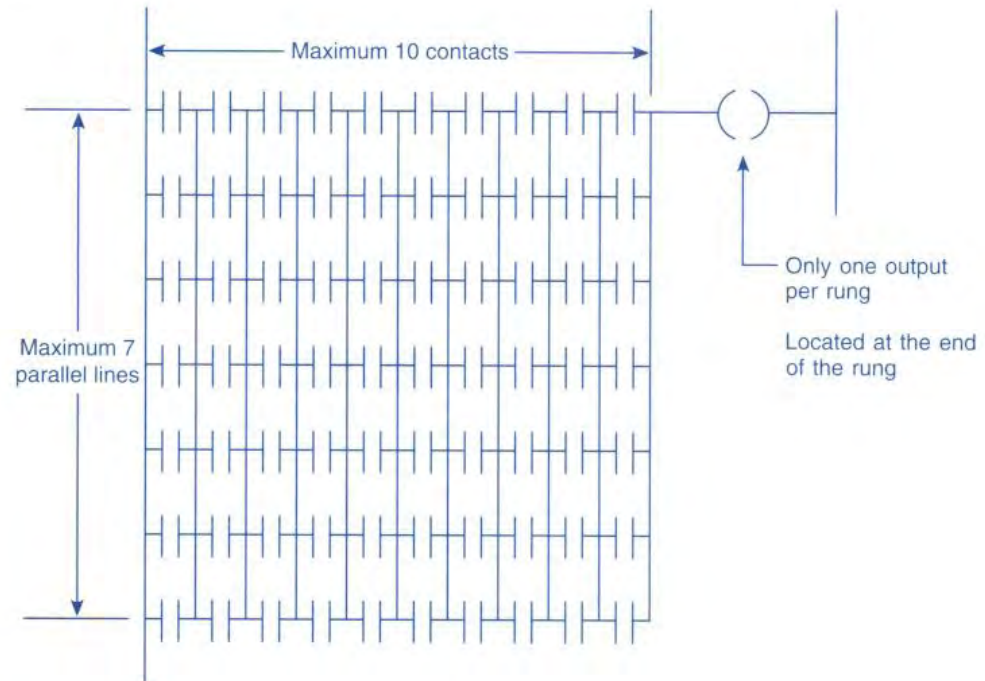
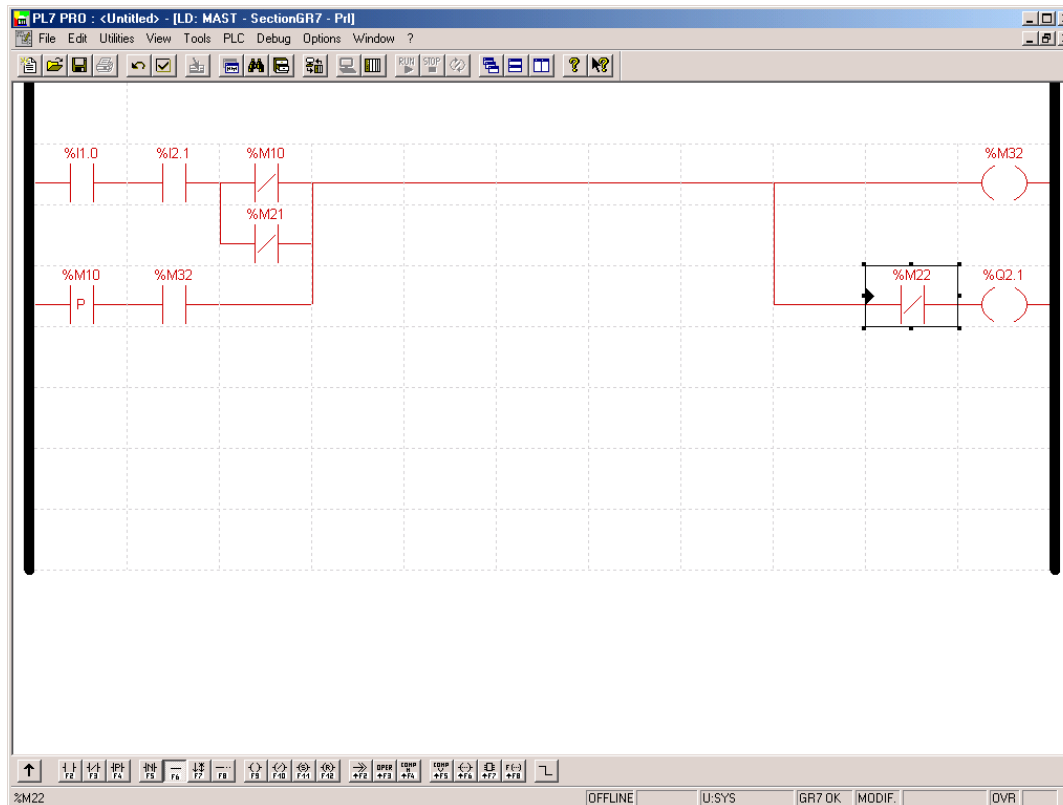

**Fig. 5-27**

Typical PLC matrix limitation diagram. The exact limitations are dependent on the particular type of PLC used. Programming more than the allowable series elements, parallel branches, or outputs will result in an error message being displayed.

## Ladder diagram Development tools

It is important to learn the potentialities and ...  
the limitations of the developing tools,  
i.e. ***STUDYING the manuals is a MUST.***



# Ladder diagram Development tools

Last but not least, *learn how to develop and debug programs*  
(and how to do some fine tuning).

The screenshot shows a software window titled "TSX DMZ 64DTK [OUTPUTS . POSITION 02]". It includes a "Debugging" dropdown, an "Outputs" dropdown, and a "Designation: 32E 24VCC+32S 0.1A CONN". Below this are buttons for "Reactivation", "Global unforcing", and a red "DIAG..." button. The main area contains a table with columns: Channel, Symbol, State, Error, Fallback, and Function. A "Channel 4 commands" panel on the right has sections for "Forcing" (Force to 0, Force to 1, Unforce) and "Write" (Set, Reset).

Channel	Symbol	State	Error	Fallback	Function
0			ERR	STOP	ALARM
1		0	ERR		
2		F1	ERR		
3		F0	ERR		
4		F0	ERR		
5		0	ERR		
6		0	ERR		
7		0	ERR		
8		0	ERR	STOP	
9		0	ERR		
10		0	ERR		
11		0	ERR		
12		0	ERR		
13		0	ERR		
14		0	ERR		
15		0	ERR		



# Ladder diagram Development tools

Last but not least, *learn how to develop and debug programs* (and how to do some fine tuning).

The image displays the Unity Pro M software interface, specifically the Debug menu and a ladder diagram. The Debug menu is open, showing various options and their keyboard shortcuts. The ladder diagram in the background shows a network with a timer T0 and a coil labeled %I0.3.0.

**Debug Menu Options:**

Option	Shortcut
Set Breakpoint	Ctrl+F11
Clear Breakpoint	Ctrl+Shift+F11
Show Breakpoint	Ctrl+F12
Go	Ctrl+F5
Step Over	F11
Step Into	F12
Step Out	Shift+F12
Show Current Step	Alt+F12
Call Stack	
Task State	
Set Watchpoint	Alt+F11
Clear Watchpoint	Alt+Shift+F11
Show Watchpoint	Shift+F11
Synchronize Animation Table	

**Ladder Diagram Details:**

- Network: t0 : [MAST]
- Coil: %I0.3.0
- Timer: T0